

6-1-2008

BS News

Follow this and additional works at: <https://arrow.tudublin.ie/bsn>



Part of the [Civil Engineering Commons](#), [Construction Engineering Commons](#), and the [Construction Engineering and Management Commons](#)

Recommended Citation

(2008) "BS News," *Building Services Engineering*: Vol. 47: Iss. 6, Article 1.

Available at: <https://arrow.tudublin.ie/bsn/vol47/iss6/1>

This Article is brought to you for free and open access by the Journals at ARROW@TU Dublin. It has been accepted for inclusion in Building Services Engineering by an authorized editor of ARROW@TU Dublin. For more information, please contact arrow.admin@tudublin.ie, aisling.coyne@tudublin.ie, vera.kilshaw@tudublin.ie.

bs news

Building services news

Refrigerant Recovery & Disposal
New Regulations Now in Force

Installer Registration — The UK Experience

CIBSE Conference 2008 Review

Designing Building Services

The **BIG** Grundfos E-boost truck is coming your way!

Mobile E-pump training facility

E-solutions from Grundfos offer pump users the power to be in control of their systems and over their power consumption. The E-boost truck has been sent on the road to make sure that this control is passed directly into the hands of the installer and user.

If you would like to see and try Grundfos' E-solutions for yourself, please contact your local Grundfos company.

Phone: 01 4089800

Fax: 01 4089830

Email: info-ie@grundfos.com

Website: www.grundfos.ie



ISSN 0791-0878

Published by:

Pressline Ltd,
Carraig Court,
George's Avenue,
Blackrock, Co Dublin.
Tel: 01 - 288 5001/2/3 Fax: 01 - 288 6966
ISDN: 01 - 211 2338/9
email: bsnews@pressline.ie
web: www.buildingservicesnews.com
www.bsnewsbuyerguide.com
www.pressline.ie

UK Office

Mike Knight
Tel: (+44) 07966 196 383
email: mike-bsnews@blueyonder.co.uk

Editor: Pat Lehane**Advertisement Director:** Joe Warren**General Manager:** Louise Byrne**Origination and Design:**

Pressline Ltd. Tel: 01 - 288 5001

Subscription: One Year —€70**Printed by:** C & F Print Solutions Ltd.

© All editorial contents and all
advertisements prepared by the publishers,
Pressline Ltd.

IN THIS ISSUE

Trade News & Product Information	2
BTU (Roganstown) Results — Danfoss Ireland	14
Institute of Refrigeration News	16
Ray Byrne — An Appreciation	18
New Room Air Conditioner from Sanyo	20
Designing Building Services	24
Another Side Off... Fergus Daly, Hitachi	31
Unitherm Receives Irish Agreement Approval	32
Grundfos Mobile E-Pump	33
Refrigerant Recovery & Disposal — New Regulations	34
RACGS at Fota Island — bs news	36
Regulation of Gas Installers — CORGI Experience	38
CIBSE Tall Buildings Conference	40
Technical (Fault Finding Can be Murder!	42
Plumblines	44

june 2008

page 1

Published by ARROW@TU Dublin, 2008

opinion

Current Scenario A Challenge — Not a Disaster

Having surfed at breakneck speed on the crest of an economic surge for near on a decade, Ireland Inc seems incapable of differentiating between boom and bust. Just as the popular media hyped the good times to ridiculous proportions, it is now almost gloating at the economic downturn.

Headline news — be it on TV, radio, the broadsheets or the tabloids — seem intent on driving markets down. Take for instance the recently-published SEI report. In “leaking” the details early on the morning of 17 June prior to the official publication later that lunchtime, RTE repeatedly focussed on the reported 62% increase in household energy consumption between 1990 and 2006.

RTE's analysis was: “It appears that our televisions are getting bigger, we have more of them in our houses, and we watch them more often. The inevitable and negative consequence of such an increase is higher greenhouse gas emissions.”

Don't be misled by such trite and ill-informed commentary on what contributes to greenhouse emissions and the related environmental — and business/financial — consequences.

There is no denying the seriousness of the challenge facing the world at large when it comes to energy sourcing and energy usage. Indeed, Ireland is particularly vulnerable given that we import 90% of our energy.

However, it is just that ... a challenge ... not an inevitable disaster. Moreover, with energy costs and energy usage central to the debate, who better than those in building services to come up with workable solutions.



'more efficient and cleaner with potterton & andrews'

Potterton Myson (Ireland) has strengthened its resolve to lead the field in energy efficiency and environmental awareness with the addition of innovative new products under the Potterton Commercial and Andrews Water Heaters brands.

The Potterton Commercial portfolio now comprises a wide range of condensing systems to meet the specific needs of today's marketplace. The choice of wall hung and floor standing models conform to, and exceed, all existing and anticipated industry regulations, and have been fully field-tested and proven before their general release.

Wall hung models include the Paramount Two (30kW to 115kW) and the Sirius WH (50kW to 110kW); the floor standing models include the Eurocondense Two (90kW to 500kW) and the Sirius FS (90kW to 160kW).

Other products in the Potterton Commercial range include prefabricated condensing modular boiler system; atmospheric gas boilers; pressure jet boilers; flue heat recovery units; and hot water calorifiers.

Andrews Water Heaters has also turned to condensing technology to further improve the performance of its extensive range of market-leading water heaters. For continuous production of hot water in domestic, commercial and industrial applications, Andrews has the perfect solution. All models conform to the various applicable regulatory standards and also carry the CE Mark.

Among the latest introductions to the range are the following:—

- MAXXflo condensing storage water heaters;
- The Standard Hi-Flo range;
- ECOflo condensing water storage heaters;
- FASTTflo continuous flow, wall hung, balanced flue, water heaters;
- SOLARflo glazed flat plate aluminium tray solar collectors.

Other items in the range include balanced flue water heaters; a fan flue range; Supa Flo water heaters; and an oil fired range.

Contact: Potterton Myson (Ireland). Tel: 01 - 459 0870; email: post@potterton-myson.ie

wavin appoints general sales manager

Michael O'Donohoe has been appointed General Sales Manager of Wavin Ireland with responsibility for all sales functions throughout Ireland, both north and south. He brings extensive experience to the position, having worked at senior executive level for a number of leading european companies.

Michael holds an M.Sc in Executive Leadership and an Advanced Diploma in Management Practice from the University of Ulster. He also has a B.Sc (Applied Sciences) Chemistry & Mathematics from the Dublin Institute of Technology and is a member of the Marketing Institute of Ireland.

Contact: Michael O'Donohoe, Wavin Ireland. Tel: 01 - 802 0200; email: michael_o'donohoe@wavin.com





GHP uses 10% of the electrical power of traditional VRF systems

- Powered by natural or liquid gas and only requires a single phase power supply (up to 70kW cooling and 80kW heating).
- Reduced CO₂ emissions.
- Reduced running costs.
- Eliminates expensive electrical power substations for new or refurbishment projects.
- Available as either a heat pump or heat recovery VRF system.
- 100% performance in heating, at low ambient down to -20°C - with no defrost cycles.
- Indoor units can uniquely control off-coil temperatures to prevent cold drafts and are connectable to up to 32 indoor units or AHUs.
- Rejected engine heat enables hot water reclaim and increased COP.

www.sanyoaircon.com

GAS DRIVEN VRF
ELECTRIC VRF
COMMERCIAL SPLIT SYSTEMS
ROOM AIR CONDITIONERS



rel guinness utopia

REL has had a long association with Guinness, providing customised solutions for draught beer and bottle cooling projects since the early 1980s. Over the years it has carried out significant work on behalf of the brewer, including:—

- Installation of all ice makers, bottle coolers and beer cold rooms at build stage in the Guinness Storehouse;
- Installation of Hitachi Utopia twin and single systems in meeting rooms, kitchen areas and offices;
- Installation of Hitachi VRF system on the 5th floor mezzanine, global branding, comms rooms and admin office areas.

Some of the most recent projects completed include:—

- Installation of two RAS 32 and one RAS 16 with 4-way cassette and ducted units in the new exit area and merchandising shop;
- Installation of Hitachi suspended ceiling units in the high-profile, glass surround, bar at the top of the building.



Ailbhe Gerrard Davis, Langdon PKS Senior Project Manager, is pictured with Dominic Kearney, Davis Langdon PKS Associate Project Manager, Seamus Brennan (then) Minister for Arts, Sports and Tourism, and Donn O'Shaughnessy, Davis Langdon PKS Partner.

davis langdon pks to project manage national sports campus

Davis Langdon PKS has won a commission to provide both project management and cost consultancy services for the National Sports Campus Development Phase 1.

Phase 1 of the development will provide high-calibre training, medical and playing facilities for soccer, rugby, gaelic games and hockey, and up to 20 other sports.

- Phase 1 of the project will utilise 205 acres of the 495-acre Abbotstown site and it is envisaged that it will be delivered within the next three to four years.

lg appoints graham hendra ac general manager

LG has appointed Graham Hendra as General Manager of its Air Conditioning Division. He previously held the position of Operations Manager with the company.

Mr Hendra has approximately 20 years experience in the UK air conditioning industry, mainly from a technical and operational background. "Because of my personal background in operations", he told *bs news*, "I will ensure that LG contractor customers get the highest level of service and attention so they can fulfil their obligations to their own customers and end-users".



pmi moves to new headquarters

As part of its ongoing distribution development — including the addition of Potterton Commercial and Andrews Water Heaters — Potterton Myson Ireland (PMI) has outsourced its logistics to facilitate a move to new operational headquarters at Unit 7, Whitestown Business Park, Tallaght, Dublin 24.

Johnston Logistics, Rathcoole, Co Dublin, with whom PMI already has a close working relationship, will now handle all its logistics. Next day delivery for stock items is just one of the advantages of this development. Stock collections will also still remain in place.

PMI will continue to run a Trade Counter from its new premises where customers can purchase genuine spares and also access comprehensive technical support. Telephone/fax numbers and e-mail addresses remain unchanged.

Contact: Potterton Myson (Ireland). Tel: 01 - 459 0870; email: post@potterton-myson.ie



UNISTRUT[®] YOUR STUFF!

You know who we are, but do you know what we do?

For guaranteed quality, a range of premium cable management products and the assurance of dealing with a global manufacturer supplying multi million pound projects, why go anywhere else?

THE ORIGINAL METAL FRAMING SYSTEM

UK Tel: +44 (0)208 561 0200 • Ireland Tel: +353 (0)1 4607060

www.unistrut.co.uk/ladder

Published by ARROW@TU Dublin, 2008

tyco

hotel-specific comfort control from carrier

Carrier's new 42CE fan coil unit was specifically designed to provide optimised individual comfort control in hotel applications. A key strength is its ability to provide customised solutions for virtually any requirement with high performance and ease of operation being the principal characteristics of the installed system.



Product features include:—

- Single-piece insulated condensate pan with internal anti-corrosion lining;
- Coil equipped with air purges with a centre distance of 40mm for the water connections;
- Centrifugal high-pressure fan/motor assembly to ensure long-term performance integrity.

Main user benefits are:—

- Air quality comfort using a G3 return air filter that absorbs 80% to 90% of particles down to a 1µm in size;
- Acoustic comfort using an insulated return air casing that reduces the noise level by -3dB(A);
- Installation comfort with a casing that allows easy air return from the rear or from below, offering a solution to system constraints.

Fast and easy installation is assured thanks to the all-inclusive concept of the 42CE unit package which includes a 230 volt thermo-electric on/off motor compatible with most available controls, plus a factory-mounted Carrier controls system.

The standard 42CE is equipped with a rectangular supply air sleeve to facilitate duct connection. Additionally, a plenum with oblong duct discharge spigots, compatible with ø200mm ducts, means that a complete system can be provided by combining it with the 35DB Carrier diffuser range.

Contact: Austin McDermott, Core Air Conditioning. Tel: 01 - 409 8912; email: info@coreac.com

A single

Europe's largest comprehensive range of Condensing Boilers



Sirius FS



Sirius WH



Eurocondense two



Paramount two WH

POTTERTON

<https://arrow.tudublin.ie/bsn/vol47/iss6/1> www.pottertoncommercial.co.uk

Potterton My
Belgard Road, Ta

Tel: 01 - 459 0870 Fax: 01 - 459 0870

trade news + product information

portable ac from gt phelan

The sustained high temperatures of recent weeks has created an unprecedented demand for portable air conditioning. Commercial office environments and retail outlets often require a simple and effective solution.



"We're fortunate in that we had sourced a full range of portable ac units in anticipation of a good summer and so are now in a position to deliver ex-stock", says Rodney Phelan of GT Phelan. "The greatest demand appears to be in the small unit sector where our cooling only 3.5kW model appears to have struck a chord. It is sufficiently powerful to be very effective and quite in operation."

"Competitively priced, other features are small chassis design; mono-bloc construction with 5ft, 125mm, diameter exhaust hose; self-evaporating (no drain required); and all-digital controls.

"To complete the package the cabinet housing is very attractive and designed to complement all modern office and retail interiors."

GT Phelan also stocks 4.5kW and 6.1kW computer room portable units.

Contact: Rodney Phelan, GT Phelan. Tel: 01 - 286 4377; email: rodney@gtphegan.ie

solution

& Water Heaters. Two brand leaders under one roof.



MAXXflo



ECOflo



R300

trade news + product information

sunvic plug-it control pack

The Plug-it Control Pack from Sunvic was designed specifically to ease the installation of controls in central heating systems by saving time on the electrical installation costs. The motorised valves, cylinder thermostat and optional pump are pre-wired to the wiring centre, with a unique colour-coded plug connector connecting to the controls.

Apart from the obvious benefits for installers, there is also the added benefit to the merchant who can supply a complete system in one box.

Plug-it Packs are supplied with a choice of room thermostats, either hard wired, or RF; time controls (1, 2 or 3-channel programmers); and a by-pass valve in the 2-port valve packs. There is a further choice of spring return or motor open/motor close motorised valves, cylinder thermostat and wiring centre.



Contact: Tom Noone, Chronotherm Controls. Tel: 01 - 410 5756; email: sales@chronotherm.ie

kentz \$208 million contract in qatar

Kentz Group (through its operating unit Qatar Kentz (W.L.L.)), has been awarded a US\$208 million contract for the design, supply and delivery of the main electrical systems on the prestigious Sidra Medical and Research Centre in Doha, State of Qatar.

The Centre project is valued at around US\$2.3billion and will deliver world class clinical care, medical education and biomedical research. Kentz has already begun preparing the scope of work for the project, which is scheduled for completion in mid-2011.

Since commencing operations in 1997, Qatar Kentz has completed 25 projects for Qatar Petroleum or Qatar Petroleum subsidiary companies, primarily in the oil and gas sector. The company is also currently carrying out major projects for other international clients in the Ras Laffan area of Qatar.

heat merchants trade catalogue

Heat Merchants has published its first-ever Trade Catalogue for contractors, buyers and specifiers.

The 200-page catalogue, which is now available at 50 Heat Merchants branches nationwide, features the full range of heating, plumbing and renewable energy products stocked by the company.

It also features Heat Merchants' private-label products now coming into all its stores. These are said to be equal to, or of better quality, than the most of the proprietary brands currently on the market and include PEX & PB barrier piping, compression fittings, radiator valves in the stores.

Heat Merchants has also introduced a new fax order form which trade customers can fill in and fax direct to their local branch. Staff will either have the goods ready for collection or deliver direct.

Contact: www.heatmerchants.ie

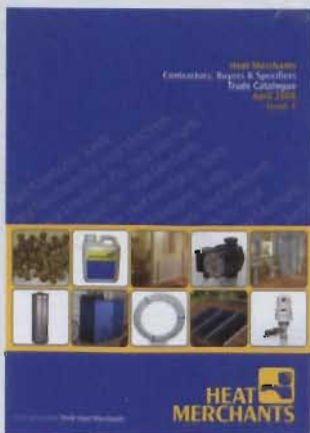



Bathroom Lighting



Commercial Lighting



Garden Lighting



Kitchen Lighting



Domestic & Commercial Lighting Showroom

Fantasy Lights Group new showcase lighting showroom comprises sophisticated displays presented in dedicated, self-contained sections devoted to:—

- Design Lighting
- Traditional Lighting
- Bathroom Lighting
- Kitchen Lighting
- Garden Lighting
- Commercial/LED Lighting
- Lighting Control Systems
- Mood Lighting

Published by ARROW@TU Dublin, 2008

fantasy
lightsgroup

enlighten

Mulcahy Keane Estate, Greenhills Road, Walkinstown, Dublin 12.
 t: 01 - 460 1052
 e: sales@fantasylights.com
 w: www.fantasylights.com

f: 01 - 460 1054
 e: sales@enlighten.ie
 w: www.enlighten.ie

wireless...

trade news + product information

xpelair from dimpco

Following the Glen Dimplex Group acquisition of Applied Energy Products — which incorporates brand-leading names such as Redring and Xpelair — Dimpco is now the distributor throughout Ireland for Xpelair.

The Xpelair name has been synonymous with fans and air-movement for over 50 years, during which time it has pioneered the introduction of new products and new technologies. Today, the need to reduce carbon emissions has led Xpelair to take a leading role in the development of the mechanical ventilation with heat-recovery products, all of which are now available from Dimpco.

For instance, the improved Premier range represents the ultimate in condensation control with features such as automatic operation, powered trickle ventilation and selectable delay timer, while the Xcell range offers a whole-house solution where condensation and damp is a problem. Xpelair has an extensive collection of fans and controllers for commercial and light industrial applications offering specifiers, installers and end-users the products and systems required to meet today's demanding market requirements.

Contact: Jason Smith, Dimpco. Tel: 01 - 842 4833; email: sales@dimpco.ie

atc blade hand dryer

ATC Electrical and Mechanical has introduced a new fast and hygienic hand dryer called the ATC Blade. Operating at only 650W (without heat option), it is said to dry hands in just 12 seconds, compared to traditional hand dryers that take 45 seconds.

The ATC blade is a no-touch, high-speed hand dryer that dries hands completely. It has an easy clean air filter and drip tray to ensure that water does not reach the floor.

The new unit should be of interest to the hospitality industry, commercial industry such as offices, factories and shops, and the healthcare sector, including hospitals and nursing homes.

Contact: Sales, ATC Electrical & Mechanical. Tel: 01- 462 5111; www.atc.ie



You hardly have to lift a finger, let alone a floorboard to fit CM Zone. With no effort, upheaval, plumbing, cabling, drilling or fuss, CM Zone provides precise, room by room temperature control...

Honeywell

WITH THE **NEW CM ZONE...**

trade news + product information

...effortless

monitoring water flow in chillers



The SFI-100T from Manotherm is a low-cost and durable flow transmitter perfectly suited to monitoring water flow in chillers or, indeed, hot water flow. It is a new unit combining the features of the proven 100

series sight flow indicator with those of the A-711T output sensor.

Comprising a robust, solid brass body and a tempered glass window, SFI-100T also incorporates a bright red speller for greater visual indication of flow through the front window, which in turn can be easily unscrewed to clean the sight flow indicator.

Ideal for outdoor applications, the flow transmitter is weatherproof and unaffected by UV light.

The A-711T output sensor has a VDC output with pulsing for flow totalisation and a proportional frequency change for flow rate. For added versatility there are two output choices — a 5 DVDC or a VDC equal to the input power supplied. The output is compatible with digital rate meters/totalisers and other electronic systems.

Contact: Bob Gilbert, Robert Gilbert or Conor Stead, Manotherm. Tel: 01 - 452 2355; email: info@manotherm.ie



... And CM Zone doesn't just save the installer energy. By heating rooms selectively and taking advantage of "external" heat sources, CM Zone offers significant energy savings very quickly paying for itself.

Honeywell

...YOU HARDLY HAVE TO LIFT A FINGER FOR EFFORTLESS, WIRELESS CONTROL

McCormack appointed SCS president

Sean McCormack, a chartered valuation surveyor and director of professional services at DTZ Sherry FitzGerald, has been elected



President of the Society of Chartered Surveyors (SCS), for the 2008/2009 session.

He is pictured (left) receiving the chain of office from outgoing president Felix McKenna, Director of Property Services at Eircam and Managing Director of its property development company Osprey Property.

gladney appointed ireland & uk cylon sales manager

Richard Gladney has been appointed Cylon Ireland & UK Sales Manager and will be responsible for both markets with a network of over 70 Cylon Approved System Integrators. He brings seven years experience in the HVAC industry to the post, having worked for Control Aer as Sales Director.

The strengthening of the team is a key part of Cylon's strategy in order to grow its position as one of the leading independent manufacturers of building control systems in Europe.

Cylon Controls is the Irish market leader in BEMS and its business model is built around its partnership with local system integrators. In Ireland it works through 10 leading Cylon Approved System Integrators which offers plenty of options when it comes to supply and maintenance of a Cylon system.

This network ensures competitive service and support for all projects, big or small, and includes Ace Control Systems Ltd; Control Technology Ltd; FlaktWoods (Ireland) Ltd; Manutec Ltd; McCool Controls & Engineering Ltd; McGregor Controls & Automation System Ltd; Pointer Controls Ltd; Sygma Automation Ltd; TechCon International Ltd; TR Control Systems Ltd.

Contact: Sophie Ranson, Sales & Marketing Assistant, Cylon Controls. Tel: 01 - 245 0500; email: Sophie.Ranson@cylon.com



nibe energy efficiency from unipipe

Paul O'Donnell of Unipipe has announced the availability of a number of innovative Nibe products which were unveiled recently at the company's Stockholm show. They include:—

- A new 60kW 1330 ground-source heat pump;
- A 1150 Model heat pump with variable speed compressor and circulating pumps;
- A neat water heater, Compact Sol, 300L cylinder with solar connections;
- New III Phase Air-Water 2025 range
- New Pellux pellet boilers with built-in domestic hot water heat exchanger.

Contact: Paul O'Donnell, Unipipe (Irl). Tel: 01 - 286 4888; email: info@unipipe.ie

3m ireland new sales representative for electrical

3M has appointed Joe Ryan as Senior Sales Representative for the Republic of Ireland, covering the company's range of products for the electrical market.

The product range is comprehensive and includes electrical components, structured cabling, equipment for utility companies such as jointing and terminating solutions, tapes and connectors, as well as solutions for telecom network operators.

3M has been operating in Ireland for more than 30 years. Joe Ryan has been with the company for all that time, mainly covering the electronics market. Extending his brief to the electrical side of the business is a logical move, as there are natural synergies across the two areas of technology.

Joe is supported by John Agnew who was recently appointed Marketing Coordinator for Electrical Products at 3M.

Contact: Joe Ryan, 3m. Tel: 01 - 280 3555; mobile: 086 - 041 1254; email: jryan3@mmm.com



fantasy lights group lighting emporium

Earlier this month Fantasy Lights Group opened new, purpose-designed, showrooms at its premises in the Mulcahy Keane Estate, Dublin 12. Located just minutes from the Walkinstown roundabout, this showcase lighting emporium caters for every market segment, be it retail, commercial or professional.

The sophisticated displays are arranged in different areas and on two levels, each one being a self-contained dedicated section. These include:—

- | | |
|-----------------------------|----------------------------|
| — Design lighting; | — Mode lighting; |
| — Traditional lighting; | — Kitchen lighting; |
| — Bathroom lighting; | — Garden lighting; |
| — Lighting control systems; | — Commercial/LED lighting. |

All the displays are fully functioning and controlled via an automated lighting management system for demonstration purposes. It is the perfect environment for installers and specifiers to bring clients to, especially given the lounge seating and private consultation room which allow for detailed discussions in a relaxed atmosphere.



Experienced Fantasy Lights Group personnel are on hand at all times to consult with and dispense advice, free of charge. Free site visits can also be arranged.

Installation services, especially in the specialist commercial and professional sector, can also be provided, and include programming and final commissioning.

Contact: Darren Keogh, Fantasy Lights. Tel: 01 - 460 1052; email: darrenkeogh@fantasylights.com



ITT

The clock is ticking

Save energy and money with Lowara

The HYDROVAR[®] variable speed controller is great news for the planet as well as your pocket.

- Reduces the energy consumption of pumps by up to 70%
- Can be retrofitted to most types of pump
- Saves money and reduces carbon dioxide emissions

Every minute counts, so contact Lowara today.

Engineered for life

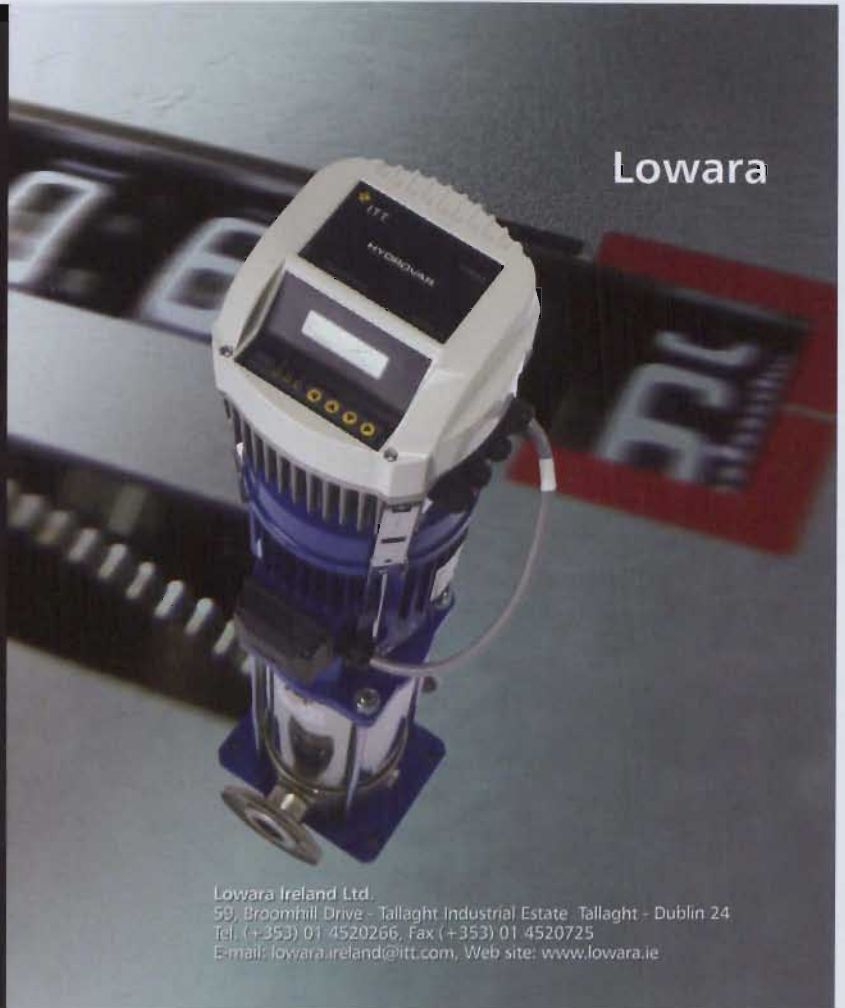

Lowara

Lowara Ireland Ltd.
59, Broomhill Drive - Tallaght Industrial Estate - Tallaght - Dublin 24
Tel: (+353) 01 4520266, Fax (+353) 01 4520725
E-mail: lowara.ireland@itt.com, Web site: www.lowara.ie

sponsor Danfoss Ireland

btu roganstown results

Overall Winner

Des Haughton 38pts (off 14)

Class 1

First — Gerard Hutchinson 37pts (less 2 is 35pts, off 5);

Second — M Matthews 37pts (less 2 is 35pts, off 8);

Third — Des Prendergast 34pts (off 7).

Class 2

First — D Haughton 39pts (less 3 is 36pts);

Second — John White 34pts (off 14);

Third — Liam McDermot 28pts (off 15).

Class 3

First — Alan Kearney 31pts (off 20);

Second — Sheamus Kiernan 31pts (less 1 is 30pts, off 16);

Third — Oliver Sharkey 30pts (off 20).

Visitor's Prize

Colm Murphy 27pts (off 10).

Front Nine

Dermot Ryan 16pts.

Back Nine

Robert Kenny 22pts.



Overall Winner Michael Brady



Kim Peterson, Danfoss with BTU Captain Michael Kearney and visitors' winner, Colin Murphy



Kim Peterson, Danfoss with Dermot Ryan, Front 9



Oliver Sharky, 3rd Class 3 with Captain Michael Kearney



Kim Peterson, Danfoss with Mick Matthews, 2nd Class 2 and Captain Michael Kearney

Butt welded aluminium



Multilayer Pex-Alu-Pex



Straight lengths & coils in sizes 16mm to 63mm



16mm & 20mm conduit sleeve
Alpex-duo Pipe in Pipe



Pre-insulated Alpex-duo
(13mm insulation)

Pressfit fittings



Compression fittings



Published by ARROW@TU Dublin, 2008

et al.: BS News

FRÄNKISCHE



- Suitable for potable water and heating systems
- 100% oxygen tight
- Flexible, easy to bend and high stability
- Corrosion resistant
- Low thermal linear expansion - compared to other materials
- High chemical resistance
- Approved for pressures up to 10 bar at 95°C
- Good compatibility with other materials
- Approved by the Irish Agreement Board and Dublin City Council



For further information please contact

Unitherm HEATING SYSTEMS LTD

Peamount Business Centre
Newcastle
Co. Dublin

9 City East Business Park
Ballybrit
Co. Galway

Tel : 01 6109153
Fax : 01 6212939

Tel : 091 380038
Fax : 091 380039



IRI Technical Programme Review

The first half of 2008 offered IRI members plenty of opportunities to participate in continuing professional development (CPD) events with seven seminars hosted by the IRI, two co-hosted with Engineers Ireland and three more hosted by CIBSE and offered to members.

The first seminar, Energy Efficiency in the Retail Sector, was presented by Michael McNerney, Energy Manager with Tesco Ireland. This was hosted by CIBSE in Cork in January 2008 and was repeated in Dublin in April 2008, this time hosted by the IRI. The presentation examined the approach to energy conservation in the construction and operation of new retail stores and the refurbishment of existing buildings. It included a review of existing processes, staff energy awareness and ownership, design of future stores, and the new "Ecostore" specifications.

February's AGM was preceded by an update on the Fgas Regulations and the new Waste Permits Legislation. These were presented by Enda Hogan and Seamus Kerr respectively.

The topic of Demand Side Management & Smart Metering was addressed at two CIBSE-hosted events in February and March as part of a consultation exercise being carried out by the CER. These events took place in Limerick and Waterford.

Michael O'Hart, Dangerous Goods Advisory Services, addressed the topic of transport regulations for refrigeration contractors at a seminar in Dublin in February. There was a lively question and answer session after the presentation, during which he addressed head-on some of the

issues that contractors and wholesalers face when trying to comply fully with road transport regulations.

Shane Fleming, Danfoss Ireland, dealt with the topic of electronic expansion valves in refrigeration systems, focusing in particular on selection, installation and control options. He shared details of a case study that demonstrated proven savings from use of an optimised AKV electronic expansion valve leading to a payback of less than two years.

Robert Macleod-Smith and Glenn D Comisac from Baltimore Air Coil presented on the topics of energy and water saving in cooling projects using ice storage and adiabatic cooling solutions. This seminar was repeated in Cork and Dublin and, in a new development for the IRI, online via the world-wide-web.

The last seminar before the summer break was on gas heat pump systems and was delivered by Vincent Mahony, Sanyo Airconditioners. Vincent explained both the technology involved and the market forces that are driving demand for these systems.

The Autumn schedule has yet to be finalised but is likely to include presentations on inspection of air conditioning systems under Article 9 of the EPBD, risk assessment and method statements, project management, HASSP and refrigerated foods, F-Gas implementation in Ireland, and compliance with the Waste Regulations.

Further information is available on the IRI website at www.instituteofrefrigerationireland.ie

IRI President & Council Elected

The Institute of Refrigeration Ireland Annual General Meeting took place recently with Joe Brennan, outgoing President, handing over the reins to Seamus Kerr. Council elections took place on the same night with 13 members taking up their place on the incoming Council.

Seamus is Chairman of Refrigeration Skillnet, a government-funded training organisation for the RAC Sector in Ireland. He is a member of Engineers Ireland Council and a member of the Government sub-committee on Legionnaires' disease (as the Engineers Ireland representative).

A full list of the IRI Officers and Council are as follows:—

President — Seamus Kerr BE, MEngSc, MIEI, MIRI, MASHRAE;

Past President — Joe Brennan;

Council Members — Robbie Burns; Derek Byrne; Mick Hannaway; Enda Hogan; Garrett Keenaghan; Dave Killalea; Paul Lynch; Michael Mullaly; Michael Murphy; Billy Reilly; Dominick Ward.



Glenn D Comisac, Seamus Kerr & Robert Macleod-Smith at the IRI Seminar on Energy and Water Saving in Cooling Projects using Ice Storage and Adiabatic Cooling Solutions

Samurai range

et al.: BS News

HITACHI

Inspire the Next

Screw Type Water Chillers Cooling Only & Heat Pump Versions

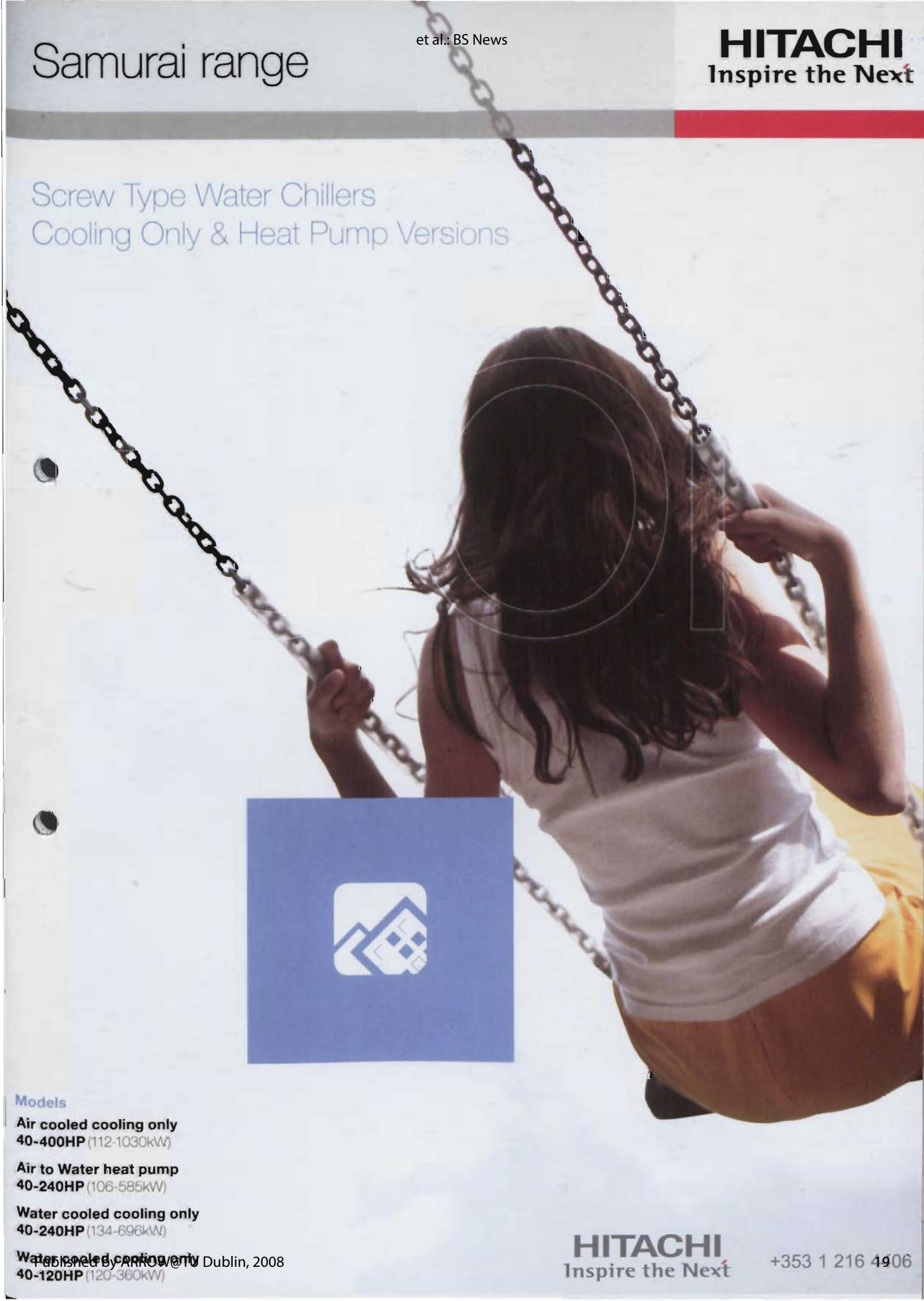

Models

Air cooled cooling only
40-400HP (112-1030kW)

Air to Water heat pump
40-240HP (106-585kW)

Water cooled cooling only
40-240HP (134-696kW)

Water cooled air flow only
40-120HP (120-360kW)

HITACHI

Inspire the Next

+353 1 216 4906

Published by ARROW@TV Dublin, 2008

Ray Byrne — An Appreciation

The death occurred recently of Ray Byrne at his home in south county Dublin after a short illness. Ray had a successful heating and plumbing business in the area and only retired a few years ago.

After retiring, Ray devoted his time to looking after his garden, playing as much golf as possible, and helping family and friends whenever the need arose.

Born in Glenageary, Co Dublin, Ray was one of nine children and the family lived in the lodge of Glengara Park School. Ray was well known in the area and at weekends and school holidays he would head to the local golf course in Dun Laoghaire where he caddied. As was the norm, after each round of golf he would have to clean the golf clubs before returning them to the caddy master.

Ray served his heating apprenticeship as a steam fitter with Brightside Engineering and later joined Farrell Engineering where he worked on the Kish Lighthouse before eventually starting his own heating business.

To say Ray was a keen golfer would be an understatement. He was a member of Old Conna Golf Club, a member and past Captain of Cabinteely Golf Society, and a member and past President of the BTU Golf Society. With his wife Mary he also supported the BTU weekends. Ray won the Captain's prize in the BTU in 2005 and was a regular player on the BTU National team, making trips to England, Scotland and Wales.

In June 1996 Ray was on the BTU National team that played the North Berwick Golf Course in Scotland. Ray's team — the Irish Provincial — had a chance for the win but a score of 40 plus points was needed from the last pairing of Ray and his partner Michael Melligan. The afternoon was drawing to a close and all hopes of a win were fading.

As some of the team made their way back across the course to the nearby hotel they saw Ray and Michael in the distance with a few holes left to play. As they got nearer to them they asked how they were going: "we're hanging in" came the whispered reply. Ah, well done lads, keep it up and we'll see you back at the hotel.

Later in the hotel news came in from the course that Ray and Michael had posted a score of 43 points giving the Irish Provincial team the win with Ray sinking the winning putt.

Ray later recalled that the evening banquet meal of cock-a-leekie soup, haggis and roast Scottish lamb never tasted better!

Say not in grief "he is no more", but live in thankfulness that he was (Hebrew proverb).

MM



Ray
Byrne

Want to guarantee your share of Ireland's €40 billion construction output?

Deadline ... Deadline ... Deadline ...
for return of completed forms is Friday, 25 July.

If you have misplaced your mechanical form or need additional forms then please contact Louise at tel: 01 - 288 5001 or email: louise@pressline.ie

Then you must be listed in the
bs news
Building Services

Product Specification Guide 2009/10

New Room Air Conditioners from Sanyo

Sanyo Airconditioners Europe (SAE) has extended its range of room air conditioning units as part of its Golden Jubilee celebrations. Four new units have been added to bring increased flexibility to the range, making it one of the most extensive and diverse on the market.

David Colbert at Sanyo Air Conditioners explains: "These latest-generation room air conditioners are among the most technically-advanced and energy-efficient systems available. We can now deliver a comprehensive series of reliable air-conditioners which customers can install without having to worry about high installation or energy costs. They also know they are assured of a great service."

The new wall mounted room air conditioning units comprise the following — 6 Series K Type Flexi Multi; 6 Series K Type Inverter; 7 Series K Type Constant Speed; and the Mini Shiki Sai Kan. Specifically designed for small to medium sized areas, these innovative units are the ideal solution for creating a quiet, comfortable environment. Brief details of each of the new series are as follows:—

K Type Flexi Multi Inverter Wall Mounted Unit (6 Series) — Designed for flush mounting against a wall, the new K Type Flexi Multi wall mounted unit has five system capacities from 4.0kW to 8.0kW. The multi-split system enables great flexibility with the ability to cool or heat up to four areas with a single outdoor unit. The DC inverter technology allows efficient heating and cooling which ensures more effective control of room temperatures than with traditional air

conditioners. Featuring an auto louver function, the unit provides optimum air distribution during heating or cooling operation. Offering three fan speeds, the motor is extremely quiet in operation.

K Type Inverter Wall Mounted Unit (6 Series) — The K Type Inverter unit boasts a stylish appearance with compact flat panel design. Designed to provide quiet energy-efficient and controllable air conditioning, the unit comes with a sleek multi-functional wireless infrared remote control featuring built-in temperature control. There is also a 24-hour clock which allows a wide variety of timer-based operations to be set.

Utilising energy efficient DC inverter technology to ensure precise temperature control, the system provides effective cooling and heating. Meanwhile, the automatic restart function allows the system to automatically resume operation at its preset program, after power is restored from a power failure. In addition, the unit's air clean apatite filter can be easily washed and re-used.

K Type Constant Speed Wall Mounted Unit (7 Series) — The 7 Series K Type constant speed unit has a stylish, sleek design which is both compact and lightweight, aiding installation. Features include an automatic restart function after power failure, cold draft prevention in heating mode, LED sterilisation function, and a built-in temperature sensor remote controller. This unit provides excellent performance and offers an economic alternative to inverter technology.

Mini Shiki Sai Kan — Following the success of the Shiki Sai Kan, Sanyo has developed a smaller version of the unit which is stylish and offers exceptional energy saving

performance — COP up to 4.31 while allowing cooling down to -15°C. Fitted with the LED photocatalytic sterilisation function, the unit efficiently combats odours, germs and bacteria and so improves air quality. The high performance Mini Shiki Sai Kan comes with a choice of five front panels to match any interior décor and ensures low noise levels during operation 22 dB (A) in quiet mode.

Utilising the non-ozone depleting R410A refrigerant, the new Sanyo units have increased system performance and energy efficiency, which in turn means lower operating costs. Power consumption during operation is substantially less than that of lower rated units and consequently both the day-to-day running costs, and full life cycle costs, are significantly reduced.

Contact: Dave Colbert, Sanyo Airconditioners Ireland.
Tel: 01 - 403 9900;
email: davidcolbert@sanyoaircon.com

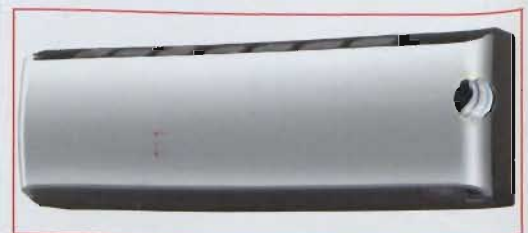

Sanyo KRV96 wall mounted room air conditioning unit



Sanyo SAP CRV unit

Want to guarantee your share of Ireland's €40 billion construction output?

Deadline ... Deadline ... Deadline ...
for return of completed forms is Friday, 25 July.

If you have misplaced your electrical form or need additional forms then please contact Louise at tel: 01 - 288 5001 or email: louise@pressline.ie

Then you must be listed in the
bs news
Building Services

Product Specification Guide 2009/10

Mr. SLIM™

- Energy Rating AA
- Easy installation and versatility
- Replace technology – reuse existing pipework
- Silent operation
- Quick clean design – automatic electric filter lowering function
- 360° I-See Air Distribution Sensor



ECOMAN FROM MITSUBI
WHATEVER THE APPLICAT
ELECTRICS COMPREHEN
AND AIR CONDITIONING
TO PROVIDE THE ULTIM
EFFICIENCY AND QUAL
ENERGY DEMAND AN

- City Multi exceeds current demands for efficiency, Seasonal Energy Efficiency Rating (SEER) of 6.26
- High sensible cooling function
- Up to 50 indoor units can be connected to a single system
- BMS compatible
- 100% inverter control on all outdoor units
- Quiet operation

CITY MULTI



FOR MORE INFORMATION CALL

01 419 8800

ISHI ELECTRIC HERE,
TION MITSUBISHI
SIVE RANGE OF HEATING
SYSTEMS ARE DESIGNED
MATE IN ENERGY SAVING
RANTEED TO CUT YOUR
D COSTS.



- Effective ventilation – fresh air and extract
- 80% recovery of waste energy
- Up to 30% reduction on heating and cooling plant
- Free cooling function
- Built in sound attenuation

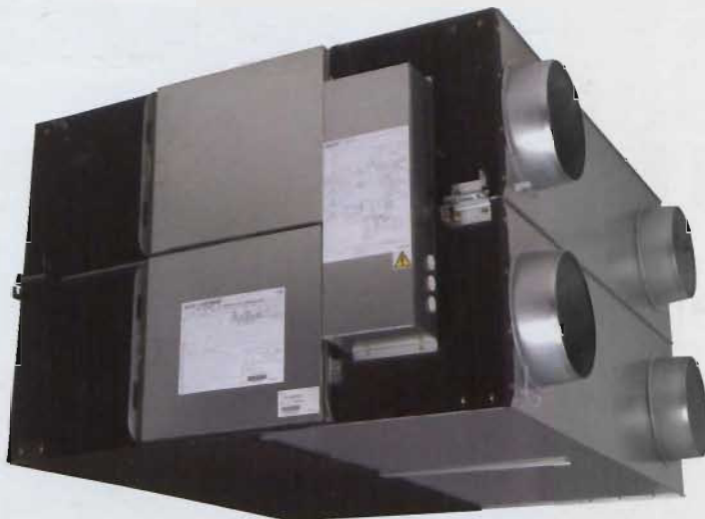

- Alternative to Gas and Oil boilers
- Easy to install – no DX pipework required
- Low operating costs – offers a 30% saving on running costs
- Converts free energy from the air and upgrades it to higher temperatures suitable for heating
- SEI Grant available
- Low carbon emissions





Con Leddy
e: con.leddy@pmg.ie

designing BUILDING SERVICES

selecting control valves for chilled & heating water in ac applications

This article outlines the technical issues that must be addressed when selecting control valves for chilled and heating water in air conditioning applications. Control valves for these applications fall into two main categories — 2-port and 3-port. The 2-port valves can be further sub-divided into pressure dependant (most common) and pressure independent (relatively new to Irish market).

Air conditioning systems operate at part load most of the time. In part load only a portion of the design flow rate is required to achieve temperature set points. Therefore, significant pumping cost savings can be realised by using 2-port valves and variable speed pumps.

The peak design flow capacity can be reduced because the system flow can be designed to deliver the peak building demand as opposed to the sum of building zone peaks as is the case for 3-port systems.

The system temperature differential (dT) is much wider with 2-port valves. Inevitably, 3-port valves will have small dT as the diverted water stream mixes with the coil return water stream. In chilled water systems with multiple chillers or heating systems with multiple boilers, small dT leads to inefficient plant

operation. It is outside the scope of this article to address this point in detail.

In industrial applications 2-port valve systems are being installed more and more.

Selecting Control Valves

Depending on the valve type, most or all of the following issues should be addressed when selecting modulating valves for heating or chilled systems:

- Valve Kvs;
- Control Authority;
- Valve Rangeability;
- Turn down ratio;
- Close-Off pressure rating;
- Bypass leakage;
- Flow Characteristic;
- Noise.

Valve Kv

Kv is defined as the flow of water, Q in m³/h, measured at 4°C (Density = 1000kg/m³) which passes through the valve when fully open for a pressure loss of 1 bar. Flow through the valve in m³/hr can be calculated from the following formula, where P is valve pressure drop in Bar, and ρ is density in kg/dm³.

$$Q = Kv \cdot \sqrt{\frac{\Delta P}{\rho}}$$

Control Authority

This is defined as the ratio of

valve pressure loss to system pressure loss. The system in this case refers to the system local to the valve where the differential pressure is considered constant. The easiest way to visualise valve authority is to think about how a sink tap behaves. Usually the maximum flow is achieved in the first one or two turns of the tap. There will be little or no change in flow by opening the tap to the fully-open position. This could be considered a valve with a poor "authority" and it would be very difficult to get accurate flow control. If a valve with such poor authority were used in a heating system then the valve would continuously "hunt", cycling from underflow to overflow and resulting in poor temperature control.

For three port valves (Figure 1) valve authority is defined as:

$$\text{Authority} = \frac{P_1}{P_2 + P_1}$$

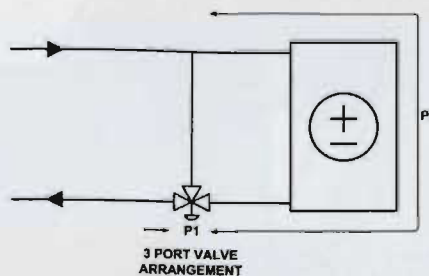
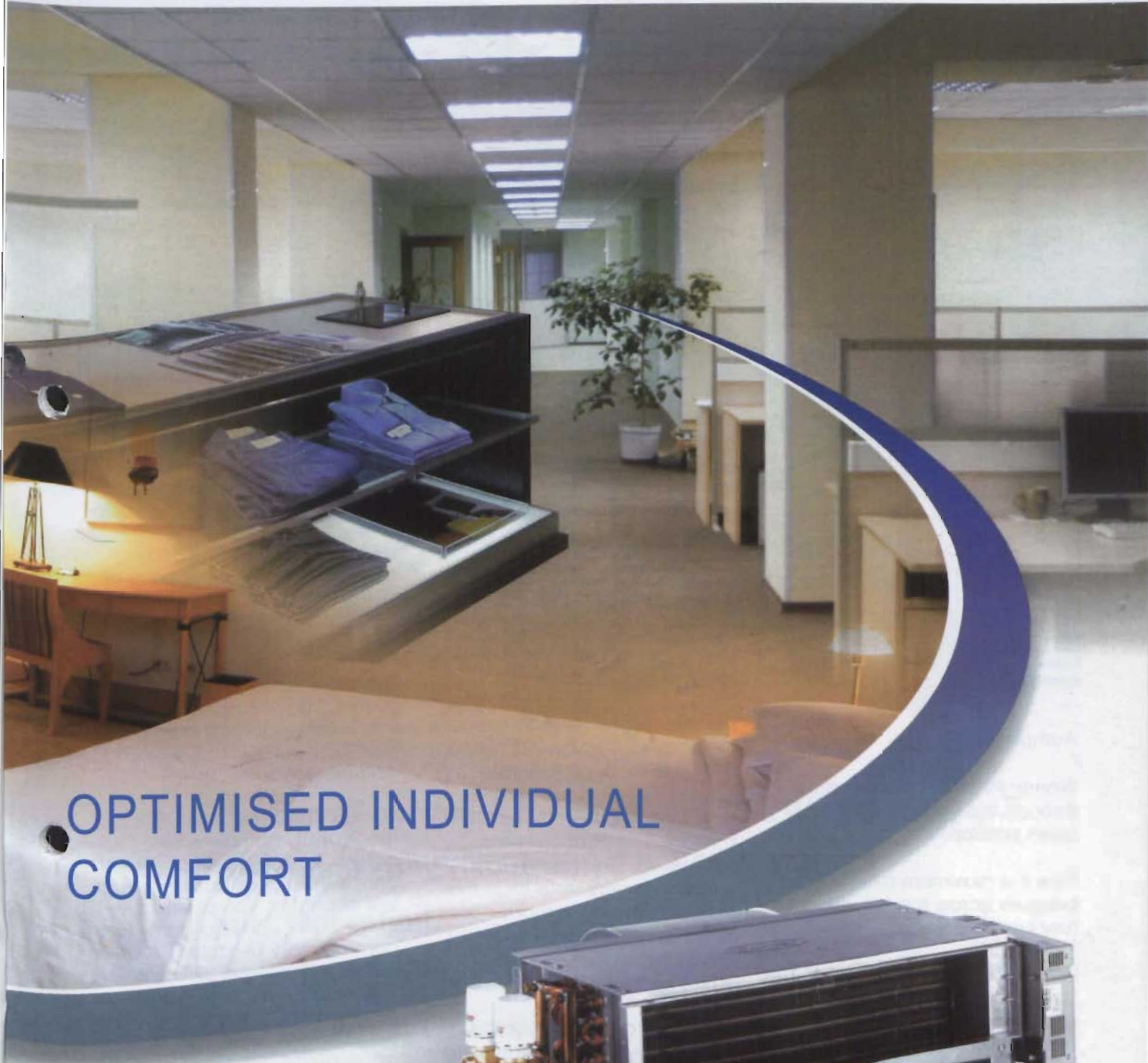

Figure 1 — Schematic of 3-port valve arrangement



42CE

FAN COIL UNIT



OPTIMISED INDIVIDUAL
COMFORT



AIR CONDITIONING LTD

Unit A6, Centre Point Business Park, Oak Road, Clondalkin, Dublin 22

Tel: 01 - 409 8912; Fax: 01 - 409 8916;

email: info@coreac.com; Web: www.coreac.com

selecting control valves for chilled & heating water in ac applications

Where: P1 is the pressure drop through the valve in the fully open position.

P2 is generally taken to be the pressure drop through the coil as the pipe losses between the valve arrangement and the coil will be minimal in most applications.

For 2-port valves (**Figure 2**) the valve authority is calculated as follows:

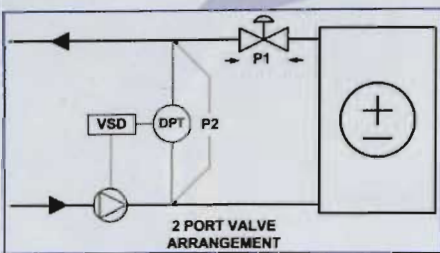

Figure 2 — Schematic of 2-port valve arrangement

$$\text{Authority} = \frac{P1}{P2}$$

Where: P1 is the pressure drop through the valve in the fully open position.

P2 is the maximum differential pressure across the valve in the fully closed position.

In **Figure 2** P2 is equivalent to the "maximum differential pressure across the valve in the fully closed position". As the valve begins to modulate from the open to the closed position, the VSD will reduce the pump speed so as to maintain P2 at its set point as measured by the DPT (differential pressure transmitter) device.

The valve authority should range between 0.3 and 0.5. For 3-port valves the exercise is fairly

straightforward. In typical 3-port applications, the objective is to make the valve pressure loss, in the fully open position, the same as the coil pressure loss.

The exercise is a bit more involved for pressure-dependant 2-port valves. 2-Port valve systems will generally have variable speed pumps. The pump speed will be controlled so as to maintain a fixed differential pressure somewhere in the distribution pipe system. This differential pressure is determined by the index circuit and this value is used for P2 (**Figure 2**) in determining valve authority.

This approach will inevitably lead to selection of valves with large pressure drops on circuits where the selected differential pressure exceeds that which is required to deliver the design flow rate. This will typically happen on systems serving AHU coils and local or zone coils, i.e. fan coil units, reheats etc. This will result in valves with very small Kv in the smaller coils and in many cases it may not be practical to select valves that will provide good authority

One way to overcome this is to use an inline 2-port modulating valve to reduce the differential pressure in the portion of the system serving these smaller coils. This arrangement is illustrated in **Figure 3**.

Valve Rangeability

This key feature of a valve is the ratio of the maximum controllable flow to the minimum controllable flow. The higher the

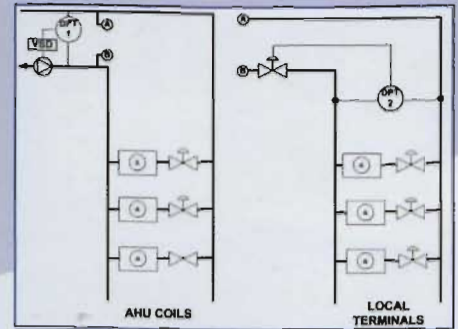

Figure 3 — Option for piping arrangement using 2-port valves

rangeability number, the more precisely the valve can control fluids that flow through pipes. For example, a valve with a rangeability of 50 to 1 and having a total flow capacity of 10L/S, fully open, will control flow accurately down as low as 0.2L/S.

For 3-Port valves a rangeability of 30 to 1 is acceptable. For 2-Port valves rangeability should be at least 50:1 but 100 to 1 is considered ideal.

In most cases, this wide rangeability compensates automatically for deviations from anticipated conditions without loss of control. Valves with a rangeability up to 50:1 are commercially available. Valves with higher rangeabilities are available from industrial valve suppliers but cost will be prohibitive for commercial applications.

Turndown ratio

While rangeability is basically the predicted stability of a control valve, the turndown ratio measures the actual stability of the valve. Turndown ratio is the single most important characteristic of a valve-and-actuator assembly's ability to control fluids. Expressed as the



PHELAN

Portable Air Conditioning



- Selection of portables ranging from 2.9kW to 6.1kW.
- Self-Evaporating (No drain) 2.9-4.5kW Units
- Quiet Operation.
- Attractive Design.
- Ideal for Small Offices and Computer Rooms.
- Large Stocks Available.

www.gtphelelan.ie

24-25 Southern Cross Business Park, Bray, Co Wicklow

Ph: 01 286 4377 Fax: 01 286 4310

mandie@gtphelelan.ie

selecting control valves for chilled & heating water in ac applications

ratio between maximum usable flow and the minimum controllable flow; this number is usually less than the rangeability.

In the above example, after the 10L/S valve has been applied in the field, it might turn out that the most flow you would ever need through the valve is 7L/S. Since the minimum controllable flow is 0.2L/S, the turndown for this valve is 35 to 1. The turndown ratio will vary depending on the combination of valve, actuator and application scenario. The ideal goal is to select valves and actuators that provide the greatest turndown ratio for any given application.

Close-Off Pressure Rating

The close-off pressure rating is defined as the maximum pressure drop that a valve can withstand while in the fully closed position and while limiting leakage to the stated leakage classification. The close-off pressure rating is a function of the actuator's power to hold the valve closed against differential pressure, but the structural parts of the valve can also be a limiting factor. The close-off pressure rating should be at least 1.5 times the maximum differential pressure that the valve is likely to experience.

Bypass Leakage

A control valve's ability to shut off has to do with many factors. The guiding, seat material, actuator thrust, pressure drop and the type of fluid can all play a part in how well a particular control valve shuts off. All valves will leak a certain amount in the closed position. Most building services valve catalogues quote

leakage as a percentage of Kvs. Ideally, the leakage should not exceed 0.05% of Kvs. Typical values are 0.05% to 0.2% of Kvs.

Flow Characteristic

Linear — Linear valves produce equal flow increments per equal stem travel throughout the travel range of the stem. This characteristic is used on steam coil terminals and in the bypass port of 3-way valves.

Equal percentage — This type of valve produces an exponential flow increase as the stem moves from the closed position to the open. The term equal percentage means that for equal increments of stem travel, the flow increases by an equal percentage. For example, in **Figure 4**, if the valve is moved from 50% to 70% of full stroke, the percentage of full flow changes from 10% to 25%, an increase of 150%. Then, if the valve is moved from 80% to 100% of full stroke, the percentage of full flow changes from 40% to 100%, again, an increase of 150%. This characteristic is recommended for control on hot and chilled water coils.

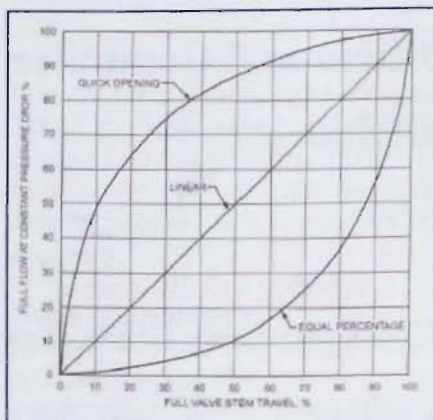

Figure 4: Control Valve Characteristics

Noise

Generally, noise should not be an issue but we have witnessed one application where one or two of the 2-port valves started to generate a loud, high-pitched, noise at a very specific point in the stem travel. The problem was eliminated by replacing the valves in question with a different manufacturer's valve. However, it is prudent to specify that the valves should not generate noise above a certain sound power level at the specified operating conditions.

A closer look at selection of 2-port valves

Again the big challenge with 2-port control valves is that, while the required differential pressure, P2 on **Figure 2**, is generally determined by the larger coils, it is difficult to get good valve authority on smaller coils with smaller control valves.

Two examples illustrate the point:—

Example 1 (Figure 5)

Load = 300kw cooling
 Flow = 11.96kg/s
 Valve Rangeability = 100
 Valve Kvs = 45
 Valve P1 at design flow = 92kPa
 System Differential Pressure loss, P2 = 200kPa

The valve authority is 0.46, which is acceptable. Note that at 50% flow rate, the cooling output of the coil will be about 80%. From the chart above 50% flow rate is achieved at 75% stem travel. Therefore, stem travel and cooling output are almost linear which is ideal.

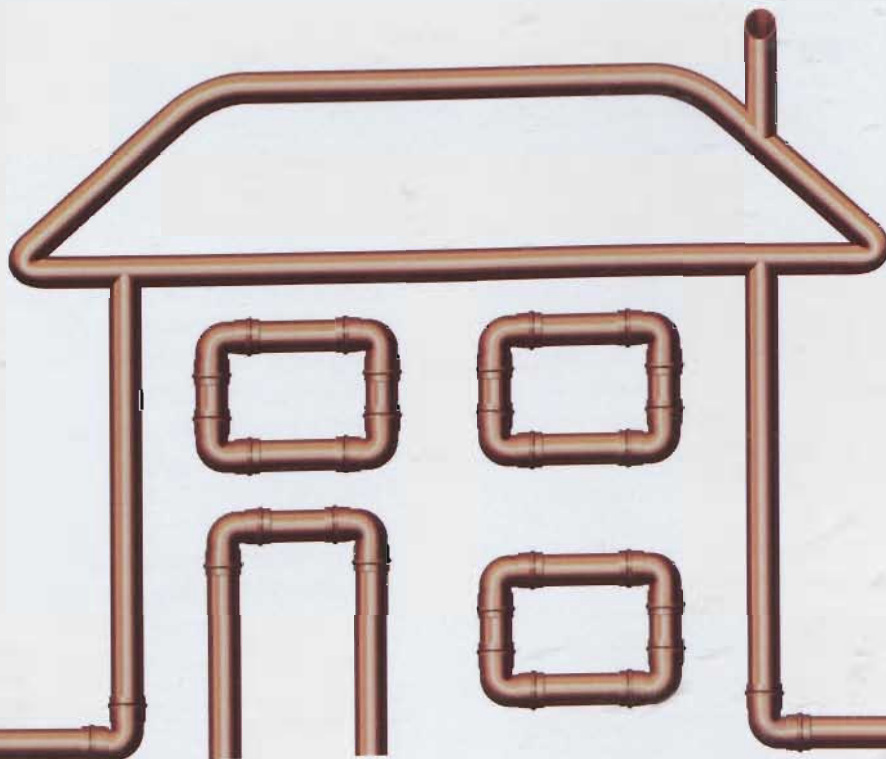

➔ **IRISH METAL INDUSTRIES:
TUBE WITH BUILT IN QUALITY**

**WHEN QUALITY AND RELIABILITY COUNT,
SPECIFY TUBE FROM IRISH METAL INDUSTRIES**

Thousands of properties in Ireland have a built-in quality product – copper plumbing tube from Irish Metal Industries. With its 25 year guarantee and carrying either the Irish Standard Mark or BSi Kitemark, our tube offers you proven and trouble-free service, year after year.

You can rely on Irish Metal Industries tube – so ask for it by name.

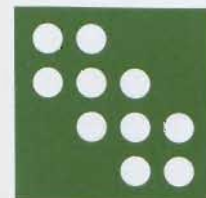

**Irish Metal
Industries**

selecting control valves for chilled & heating water in ac applications

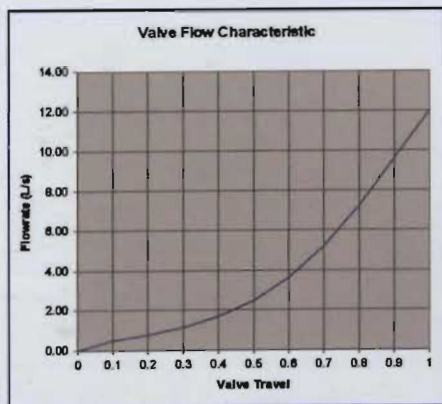

Figure 5 — Flow characteristic for valve in Example 1

Example 2 (Figure 6)

Load = 5 kw cooling
 Flow = 0.2 kg/s
 Valve Rangeability = 50
 Valve Kvs = 1.6
 Valve dP at design flow (P1) = 20kPa

Note that the system dP is set at 200kPa by the larger valve. In this case, the valve authority is 0.1 and the control is poor. The valve will overflow above 73% open. With the valve fully open, it will flow 0.36L/S, while design flow is 0.2L/S. Therefore, the valve turndown is reduced to 28. The overflow can be eliminated by the balancing valve but the valve authority does not improve.

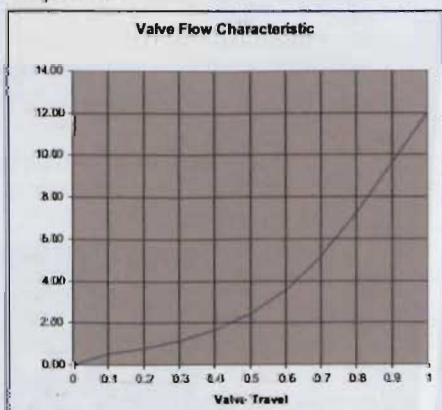

Figure 6 — Flow characteristic for valve in Example 2

Pressure Independent 2-Port Flow Control Valves

The challenge of selecting conventional, pressure-dependent, 2-port valves is eliminated with the "pressure independent" flow control valves. These valves are designed to dissipate excess system pressure allowing the flow control part of the valve assembly to work against a fixed differential pressure. This will, therefore, provide ideal valve authority.

Furthermore, each valve is set to deliver the design flow rate once the valve is fully open and a minimum differential pressure is achieved. This eliminates the requirement for balancing valves and for hydronic balancing.

These valves will be more expensive than the typical, pressure-dependent, commercially available 2-port valve. However, given there is no requirement for balancing valves or flow commissioning in the field, we have found that the "system" cost is about the same. The pressure independent 2-port valve saves design and commissioning time while providing superior performance over the pressure-dependent valves.

Conclusion

3-Port valves are easy to select but are energy-inefficient, particularly on larger hydronic systems. 2-port valves should always be considered for larger hydronic systems. For the

standard pressure-dependent type 2-port valve, ensure the rangeability is at least 50:1 and that the valve/actuator assembly is capable of closing against the maximum differential pressure across the valve. Also consider segregating larger valves on, say, AHU coils from the smaller terminal valves by using an in-line 2-port valve to provide a reduced differential pressure for these units.

Pressure independent 2-port valves are now available in the Irish market. These valves provide all the benefits of 2-port valve systems while reducing design and commissioning time.

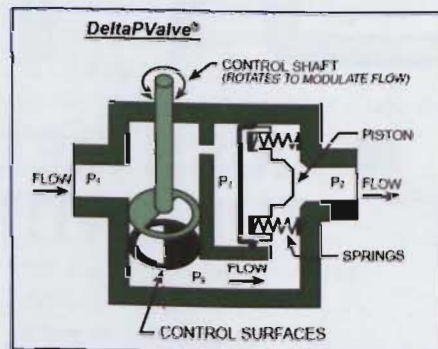

Figure 7 has been provided courtesy of Induchem Ireland Ltd and illustrates how its "pressure independent" 2-port valve operates.

Con Leddy is an Associate Director of PM Group. He's a member of PM's Technology Group and is responsible for energy-efficient design initiatives. Con has 20 years experience in the design of mechanical services for a wide variety of clients and sectors, particularly in biopharmaceutical and medical devices.

Another Side Of ...

Fergus Daly



Can you tell your Choy Lee Fut from your Bushido Karate Gendi, or your Goshin Kai Jiu-Jitsu from your Tae Kwon-do? ... Fergus Daly, Hitachi Sales Manager for Ireland, can.

Fergus has been involved with martial arts since he was 16, coincidentally the year he also entered the refrigeration and air conditioning business. The mental strengths and discipline associated with the sport have served him well in his work down through the years, though he is quick to point out that he never used his fighting skills to gain an advantage over a competitor!

Karate was Fergus' first introduction to the martial arts. He took to the sport easily and enjoyed learning and perfecting the "forms" or "kata" — the various sequences of movements and techniques — as much as he did applying them in competition.

However, having achieved a high level of proficiency at

karate, he moved on to Choy Lee Fut kung-fu, the famous rocket-punching chinese martial arts system. This is perhaps more demanding than karate and, more to the point, involves weapons such as the Chinese broadsword and the bow staff. However, these are not used in fights, only in the more intricate "forms".

That said, they are real weapons, so great control and mental discipline is required when engaging in the sport. Fergus and his club mates also registered their weapons with the local Garda, and were especially vigilant when transporting them.

Like most Japanese and Chinese martial arts, Choy Lee Fut is as much about mental concentration and mental strength as it is about the physical aspects of the sport. Meditation and focusing on one's inner energy, or "chi", is essential and this, in turn, is something which Fergus has used to great effect in his personal and business life.

But so much for Choy Lee Fut. After a couple of years of this Fergus took up kick-boxing, yet another combative martial arts sport. Kick-boxing is fiercely competitive and something which Fergus took to with tremendous enthusiasm. He fought at inter-club level all over the country and admits that the adrenaline rush when first squaring up to an opponent was exhilarating.

Given the nature of the various martial arts he participated in, it is hardly surprising that a major injury put a stop to his involvement in competitions. Surprisingly, it was not sustained through the sport but rather a serious motor bike accident. He dislocated his shoulder so badly that it took two separate operations to repair the damage.

That said, he still engages in the sport on a personal level, regularly going through a routine of the various "forms". This not only helps him keep physically fit but is also a means of stress release and relaxation.

Unitherm Receives Irish Agrément Approval for Alpex-duo & Turatec Multilayer Pipes

Unitherm Heating Systems — with offices in Dublin and Galway — has received Irish Agrément Board (IAB) approval for its Alpex-duo® and Turatec® multilayer pipes and fittings. Manufactured by Frankische Rohrwerke who are based in Germany, these multilayer composite pipe and fittings were relatively new to the IAB and so in-depth examinations had to be carried out to verify the testing procedures and results from some of the top European testing institutions. The fact that IAB approval has been granted is testament to the high quality and long-term reliability of the Frankische/Unitherm pipes and fittings. Alpex-duo and Turatec pipes are already approved for use by Dublin City Council.

Unitherm Director Declan Kissane told *bs news*: “The demand in Ireland for multilayer pipes has grown steadily in recent years and this has led to many poor-quality products entering the market. Unfortunately, visual inspection alone will not always determine the quality differences between the reputable manufacturers of multilayer pipes and those supplying sub-standard products. However, now that a precedent Irish approval has been achieved, consultants, specifiers and installers should insist on quality products being used before it’s too late”.

Frankische composite multilayer pipes can be used for drinking water systems, for heating systems within given long-term capacity ratings (95°C @ 10bar), for rainwater lines, for compressed air lines, for chilled water systems and for carrying other mediums, e.g systems with anti-freeze and disinfection agents. Some of the advantages of multilayer composite pipes are as follows:—

- 100% oxygen tight;
- Corrosion resistant;
- Flexible to use – easy to bend, lightweight and high stability;
- Low thermal linear expansion (compared to copper);
- Approved for pressures up to 10 bar;
- Resistant at high temperatures of up to 95°C long-term and 110°C short-term;



- High chemical resistance;
- Excellent noise propagation properties;
- Good compatibility with other materials;
- Hygienically-sound, incrustation-free (no calcification build up in pipes).

Alpex-duo is a quality, multi-composite, pipe consisting of high temperature-resistant crosslinked polyethylene (PEX) inner and outer layers and a laser TIG welded aluminium intermediate layer. The three layers are specially bonded together to create a high-quality pipe that ensures longevity and functionality and endures highest demands.

Alpex-duo is available in sizes 16mm, 20mm, 26mm, 32mm, 40mm, 50mm and 63mm. All sizes are available in five-meter lengths and the 16mm, 20mm and 26mm are also available in coils. The 16mm and 20mm are also available in a red or blue protective sleeving and available pre-insulated with 13mm thick insulation.

Turatec is another multi-composite pipe for use in potable and heating systems and consists of high temperature resistant polyethylene (PE-RT) inner and outer layer and a TIG welded aluminium intermediate layer. Turatec pipes are more flexible yet hold their stability and are therefore ideally suited for underfloor heating systems. Available in sizes 16mm (100mt, 200mt and 500mt coils), 20mm (100mt coils), 26mm (50mt coils) and 32mm (50mt coils).

Frankische also manufactures a comprehensive range of crimp fittings to suit the range of composite pipes. The fittings are manufactured from high-tensile, high-impact polyphenylsulfone or dezincification-resistant brass and guarantee fast and reliable installation for any application. There is also a full range of compression fittings up to 32mm. All fittings are compatible with the range of Alpex-duo, Turatec and ff-therm (PEX) pipes.

Contact: Declan Kissane or Peter Lynskey, Unitherm Heating Systems.
Tel: 01 - 610 9153; 091- 380038;
email: info@uni-therm.net

The need for reduced energy consumption and corresponding CO₂ emissions is widely accepted across the entire building services spectrum. That said, one particular market segment — pump manufacturers — have shown great leadership in devising a self-regulating energy labelling initiative to which most producers subscribe.

This in turn has led to innovative developments in pump technology, most notably the use of electronic speed controls. However, the most pressing issue now is getting the message across to specifiers and end users.

Gordon Barry, General Manager, Grundfos Ireland, explains. "We can tell people that electronically speed controlled pumps will save time and money. We can tell them that this is because the pumps automatically adjust their speed to match the pump system's demand. We can tell them that almost all Grundfos pumps can be speed controlled. However, it's not until they have seen it for themselves, not until they have seen how easy it is to commission a variable-speed E-solution and seen the impact on power consumption, that they will be convinced.

"So, we at Grundfos have put our E-solution demo systems and training materials into a truck with the intention of taking the message directly to specifiers and end users. This is not just any truck. This truck folds out into an air-conditioned, conference room (which holds 30 people), and a training facility with six full-scale demo systems. We also do fresh coffee".

The tour has already commenced with the truck currently traversing mainland Europe. This schedule will continue throughout the summer and autumn, the intention being to begin the Ireland leg sometime next November.

Among the product news featured on board is a wall-mounted frequency converter, the Grundfos CUE. It can be connected to any Grundfos motor and provides the same functions as an actual E-pump with integrated frequency converter. With the CUE solution, users can control the speed of virtually any Grundfos pump, irrespective of size, power range and application area.

In the mobile conference room, training staff can instruct customers in how to install and commission a CUE solution. This could, for example, be how to convert an existing, fixed-speed pumping system into a cost-saving E-solution. They can also advise whether an external CUE solution or an E-pump with integrated frequency converter is the right solution for a given situation.

E-solutions from Grundfos offer pump users the power to be in control of their systems and their power consumption. The E-boost truck is on the road to make sure that this control is passed directly into the hands of the installer and user. Make a note to see and try Grundfos' E-solutions for yourself.

Contact: Deirdre Flynn,
Grundfos (Irl).
Tel: 01- 408 9800;
email: dflynn@grundfos.com

Grundfos Mobile E-Pump — Experience the Reality



Refrigerant Recovery & Disposal — New Regulations Now in Force



The Waste Management (Collection Permit) Regulations 2007 and Waste Management (Facility Permit and Registration) Regulations 2007 came into force on 1 June 2008. In this article, Seamus Kerr, President of the Institute of Refrigeration Ireland (IRI) gives a general outline of the legislation as it applies to the RAC sector in Ireland.

The Institute warmly welcomes the new Waste Permitting and Collection Regulations which came into force on the first of this month. The new regulations should greatly facilitate the recovery, recycling and/or destruction of waste refrigerants by responsible companies using suitably-qualified personnel.

The Institute has been calling for these changes since April 2006 and fully supports the immediate enforcement of the new legislation. In saying this, the IRI expects to have the active assistance of the relevant authorities in explaining the new regulations to IRI members and in supporting the smooth implementation of the regulations over the coming months.

The Legislation

The new Waste Regulations amend and replace the Waste Management (Permit) Regulations, 1998 and the Waste Management (Collection Permit) Regulations, 2001 respectively. They provide for a system of permitting by local authorities of

commercial waste collection activities and the permitting or registration of waste facility activities. The regulations set out procedures for making permit applications, public consultation, consideration by local authorities of submissions in relation to permit applications, and the grant, refusal and review of permits by local authorities.

The implementation of these Regulations will also give effect to various requirements of EU waste legislation.

General Principles

The primary purpose of the permitting system is to facilitate appropriate controls on commercial waste activities for the purposes of environmental protection. The Regulations are not intended as a mechanism to limit the scope of operations of commercial collectors, or in any way to regulate competition between operators.

All commercial collectors permitted by an authority will be subject to equivalent controls

and obligations, and conditions attaching to permits should not be such as to distort competition between operators and should be reasonable and proportionate.

In recent weeks local authorities have been receiving guidance from the EPA, in association with the Department of the Environment, Heritage and Local Government, in relation to implementation issues. Detailed guidance notes have been published on the EPA website for the benefit of both Local Authorities and the various stakeholders.

Waste Management (Collection Permit) Regulations

The Waste Management (Collection Permit) Regulations 2007 (S.I. No. 820 of 2007) provide an exemption from the requirement to hold a waste collection permit in the case of the collection and transport of waste, returned or recovered refrigerant gases in refrigerant containers, where recovery has the meaning assigned to it under Regulation (EC) No. 2037/2000

and Regulation (EC) No. 842/2006, by a person where: –

- (1) such transport is incidental to the main business activity of the person concerned;
- (2) the person concerned is operating on a small scale and is engaged in environmentally-beneficial operations facilitating the recycling, reclamation or destruction of recovered refrigerant gases in accordance with the relevant legislative requirements for the specific refrigerant gas type;
- (3) the quantity of waste, returned or recovered refrigerant gas transported in refrigerant containers by the person concerned is equal to or less than two tonnes;
- (4) the person has given prior annual notification to the Agency (EPA) in accordance with the requirements prescribed in the fifth schedule and has received an acknowledgement of this notification from the Agency;
- (5) the handling and transport of the refrigerant gases is carried out in a manner that prevents the venting or leakage of these gases to the atmosphere;
- (6) no mixing of different refrigerant gas types occurs;
- (7) the transport of the waste, returned or recovered refrigerant gases in refrigerant containers is to an authorised facility where it will be stored in accordance with the rules as set out in the fourth schedule of the Waste Management (Facility Permit and Registration) Regulations 2007;

- (8) the waste, returned or recovered refrigerant gases will eventually be recycled, reclaimed or destroyed at an authorised facility in accordance with the relevant legislative requirements for the specific refrigerant gas type.

The recovered refrigerant will be temporarily stored at a registered facility and transported from there to a recycling/destruction facility in UK or Europe. Export of waste abroad will have to comply with Trans Frontier Shipment regulations (TFS) and Dublin City Council as the sole national competent authority in this regard. The "waste management" refrigerant wholesale companies will issue documentation allowing the tracing of the recovered refrigerant.

Waste Management (Facility Permit and Registration) Regulations

Under the Third Schedule Part II of the Waste Management (Facility Permit and Registration) Regulations 2007 (S.I. No. 821 of 2007), each individual authorised facility will require a Certificate of Registration from the Local Authority in which functional area the depot is situated, subject to the general and additional rules specified at the Fourth Schedule, Parts I and III, and providing the amount stored at any one time is less than 18 tonnes. Cost for registration of certain activities in this case would be €300 per individual certificate. Storage volumes exceeding 18 tonnes at any one time will require a waste licence from the EPA

Implications for contractors and end-users

The main implication for contractors and end-users of refrigerants is that they now have a number of options available to them when arranging the collection and transport of waste, returned or recovered refrigerant gases. They can continue to avail of the services of suitably-licensed refrigerant wholesalers or waste operators to collect waste refrigerant gases directly from site:

They can also submit Prior Annual Notification to the EPA which will allow them to collect and transport waste refrigerant gases from site themselves and to deliver these to authorised facilities, i.e. suitably-licensed refrigerant wholesalers or waste operators.

Prior Annual Notification

The Environmental Protection Agency has published a Standard Form for Prior Annual Notifications. This form is now available on the EPA website, together with a Guidance Manual on the Waste Collection Permit Regulations. See: www.epa.ie/downloads/advice/waste/wasteregulations/

The EPA has made it clear that the collection and transport of waste, returned or recovered refrigerants by operators is in breach of the Waste Collection Permit Regulations, unless a Prior Annual Notification has been submitted to the EPA, as per the Regulations. These requirements will be actively enforced by the EPA.

Contact: Enda Hogan, IRI.
Tel: 058 4421;
email: info@instituteofrefrigerationireland.ie;
www.instituteofrefrigerationireland.ie

racgs at fota island

The most recent RACGS outing — at Fota Island Golf Club in Cork — saw 29 golfers tee off in glorious sunshine. Conditions were perfect, if a little too hot, with the European Tour standard course in magnificent condition.

There was a strong contingent from within the Munster region but those who had travelled from Dublin and further afield were rewarded with a fantastic day's outing. Most stayed for the dinner and presentation of prizes, many staying over and returning home the next day.

Results were as follows:—

Overall Winner

Stephen Mahon (36pts).

Class 1

Winner — Bill Queally (36pts);

Second — Ger Darcy (32pts).

Class 2

Winner — Frank O'Sullivan (34pts);

Second — Mattie Kiely (33pts).

Front Nine

Dylan Reiss

Back Nine

Vincent Barrett

Visitors

Winner — Neil Parkes (29pts)

Second — Dermot Corrigan (28pts)

Longest Drive

Gary Healy

Nearest the Pin

Ger Darcy



Captain Bill Queally presenting Stephen Mahon with his Overall Winner prize with Joe Warren, *bs news*, sponsor, in attendance



Ger Darcy with David Kirwan, Billy Queally and Liam Carroll



Billy Queally, Captain with Ger Darcy, Second Class 1 and Nearest the Pin; and Joe Warren, *bs news*, sponsor



Billy Queally, Captain with Gary Healy, Longest Drive



Jamie Qually with Jack Elstead, Mattie Kiely and Neil Parks



Ken Healy with Gary Healy, David Taylor and Joe Warren



John Lynagh with Vincent Barrett and Kieran Ellis



Billy Queally, Captain with Dylan Reiss, winner Front Nine



Pat Lowry with Ronan Bradley and Mark Kiely

Joe Cooling with Matt Buttler and Michael Clancy



Michael McLoughlin with Brian Carty, Dermot Byrne and Dermot Corrigan



Billy Queally, Captain with Vincent Barrett, winner Back Nine; and Joe Warren, *bs news* sponsor

Regulation of Gas Installers

The UK/CORGI Experience

Last November *bs news* featured an interview with James Murray, CORGI Area Operations Manager in Ireland, in which he outlined his role as part of the consultation process being conducted by CER with regard to the impending registration of gas installers. With the process now at an advanced stage and mandatory registration scheduled for 1 January 2009, we returned to James this month for an update. We particularly asked for a resume of the UK experience so that installers, suppliers and the industry at large could draw parallels and gain an insight into the issues which arose in that jurisdiction. His report is as follows.

The successful implementation of any scheme depends on it being able to meet the different needs of the market and installers' expectations of a mandatory scheme. In order to achieve this, it is crucial to receive input from the operatives affected throughout the process. With that proviso in place, how did the UK go about its move to compulsory registration? ... these are some of the factors we experienced.

A statutory registration scheme was introduced in Great Britain on 1 April 1991. Prior to this a voluntary scheme, established by and partially financed by the

British Gas Corporation, had been in place since January 1970. The voluntary scheme itself was introduced following a number of major gas incidents in the late 1960s, in particular the incident that led to the collapse of the tower block at Ronan Point, East London.

Initially formed as the Confederation for the Registration of Gas Installers (CORGI), the move was welcomed by the gas industry as a positive step forward. The initial terms of reference for the Confederation limited its activities to technical gas safety matters, with a focus on promoting gas safety and satisfactory standards in installation.

The move towards privatisation of the UK gas industry in the mid-1980s helped to drive a parallel effort to identify a successor organisation to the Confederation. At this stage many of the discussions centred on the scope of any new organisation – what would it be responsible for? would it seek compulsory registration? what about an independent certification scheme for determining competency for individual operatives?

Initially the GB government was unconvinced but, by 1988, the Health and Safety Commission was considering these moves. However, the view was that implementing both proposals simultaneously would be too great a burden for industry and that the certification scheme



should be delayed until such time as industry had fully adapted to compulsory registration.

Engaging with the installers

Although the Health & Safety Executive (HSE) anticipated that all applicants for the statutory register would receive a pre-registration inspection followed by a work inspection during the first year of registration, this was not achievable. Because of resource issues, CORGI moved towards giving applicants who had been registered with the voluntary registration body (ie, the Confederation) "grandfather rights" for entry on to the statutory register, usually with a work inspection during the first 24 months of membership.

In the Republic, I understand that installers who are members of the current voluntary RGI scheme will be "grandfathered" into the new scheme, as the

Body could be confident they are competent to carry out safe gas work.

Early UK criteria

There were a number of key elements to the early shape of the scheme:—

Independence – Free from commercial influence from the industry;

Simple – Registration arrangements should be simple, well publicised and efficient;

Accountable – It would have clearly established arrangements for dealing with complaints from the public;

Finances – The Regulatory Body should be financially viable, funded by fees from installers (which should be set at a reasonable level).

Early issues

Early in the life of the UK scheme it became clear that there were some issues which could have been handled more effectively. These included the following:—
A single body – A clear statement on the legislation ensuring that only one body could run a scheme at any one time. The original definitions left this open to debate, creating potential confusion on the minds of the public as to who was responsible for gas safety;

Clear governance – Clearly-defined performance requirements on behalf of the scheme provider would have been better for all;

Financing the scheme — It was agreed at the time that registration would be a one-off fee across the board for single installers and, for larger businesses, a one-off fee plus an extra charge for additional operatives.

This cost would include all of the inspection processes the business would require and any administration through correspondence required (such as inspection reports, etc).

This was based on projected operational costs and the projected number of registered members paying up-front for membership.

Inevitably, whenever there is a mandatory fee, there will be a small minority who remain vocal on the topic of the cost of registration but, in the main, the concern has been around the cost of re-taking ACS qualifications every five years.

For the future, CORGI is considering a pro rata charge for registration based on the amount of inspections required. This would benefit the more efficient installers and penalise operatives/businesses who cause the registration body problems through justified complaints, etc.

Clarity about commercial activity – What will be allowed?, how will this be managed?, how will it be reported? In the UK all profits from commercial activity are returned to CORGI Trust, the registered charity, to help further communicate gas safety messages and promote public awareness.

On a related note it is important to clearly establish who will own the “brand” for the registration scheme. I understand this would be held in the Republic by the Commission, supporting continuity and lowering the risk of confusing the public should the scheme operator change.

The CORGI brand is now synonymous with gas safety and customers know to use CORGI-registered installers to ensure

safe gas work. In order to develop this, stamping out illegal gas work has been a key issue. To support this we have established a team to uncover these workers and support them to become registered. Ultimately, the key to stamping out illegal workers comes from prosecutions via the HSE.

Also, registered installers are able to notify new installations online or over the phone. This process is proving successful and is creating a more streamlined process for both our members and their customers.

Understanding the market

For any potential operator of a mandatory scheme it is vital that they have a clear understanding of the market and what it needs. CORGI is interested in developments in the Republic and, while we have not yet decided if we will tender as part of the public selection process run by the CER, we have undertaken some initial, high-level research into who is out there and what they would need from the scheme. Creating a culture of consultation and ownership between the regulatory bodies and the membership is vital if the scheme is to succeed.

Moving Forward

The planned introduction of mandatory registration provides a chance for the CER to develop a scheme to suit the needs of the Irish market while, at the same time, considering experiences of similar schemes. We would like to remain in contact with Irish installers and are happy to discuss the UK scheme. Please visit our website, www.trustcorgi.com/ireland for further information, or email ireland@trustcorgi.com.

CIBSE News

CIBSE Tall Buildings Conference Review



Morning Session 1 Speakers and Chair — Conor Skehan, DIT Strategic Planner with Margaret Dolan, (then) CIBSE Republic of Ireland Chairman; Nigel Clark, Hilson Moran Partnership; and Tom Phillips, Tom Phillips & Associates.



Brian Duffy, Traynor O'Toole Architects with Derek Mowlds, CIBSE



Frank Dougan, Faber Maunsell with Justin Keane, John Sisk



Morning Session 2 Speakers and Chair — Julian Sutherland, Arup Group with Nigel Clark, Hilson Moran Partnership; Gerard Keating, now CIBSE Chairman, Republic of Ireland Region; Professor David Charters, BRE UK; and Alan Duggan, Arup and CIBSE Republic of Ireland Region Treasurer.

Being very much involved in organising, supporting and promoting the CIBSE Republic of Ireland Region Annual Conference, *bs news* has adopted a policy of inviting one of the speakers — preferably from abroad — to give their independent impression of the event. This year the “honour” fell to Nigel Clark, Technical Director, Hilson Moran, who delivered not one but two papers at the conference. Down to present one session, Nigel gallantly stepped in to the breach to fill another slot when the scheduled speaker unavoidably had to withdraw. Here he recounts his experience of the conference.

Being asked to present at this year's CIBSE Republic of Ireland Region Annual Conference was an opportunity I couldn't refuse, as it gave me the perfect excuse to visit Dublin again after many years.

Held in the beautiful setting of the historic Clontarf Castle, the conference organising committee had obviously worked hard to pull the conference together and they are to be congratulated for their efforts in organising a very successful event.

As a visitor, it was a pleasure to see such a strongly-supported and active CIBSE Region. Many regions in the UK would be envious if they saw it first hand as I was fortunate enough to do.

From the minute I arrived to the very end of the day, I was made to feel extremely welcome and thoroughly enjoyed the conference, meeting so many people who obviously love what they do.

The usual IT issues that beset even the best organised events reared their ugly head the night before, but this, and even the late withdrawal of one of the speakers, did nothing to dampen the organisers' spirits, or prevent them from delivering what was a well-supported and informative set of presentations.

The topic of “tall buildings” is a passion of mine and it was clearly a good choice of subject for the conference. Judging by the questions and discussions during the breaks, the subject of tall

CIBSE News



buildings is of huge interest at the moment, particularly looking at the fantastic development opportunities that exist in the Republic of Ireland over the coming years.

The varied range of presentations meant that there was something for everybody and served to illustrate still further some of the high-quality buildings the area already has to offer.

As a designer, I'm always intrigued as to why we are doing the things we do, so I can better understand how best to contribute to the process. So, as a visitor, I found the presentations on *Tall Buildings in Dublin's Future* and the *Planners Perspective* very useful in getting to know the region better.

Personally, I found the content of some of the manufacturers' presentations a little limited and perhaps better suited to a more technical seminar rather than an annual conference which arguably should be more focussed on the bigger picture. However, that's not to say they didn't include good material that we as designers need to be familiar with in order to deliver what is frequently asked of us.

Understanding the reasoning behind where and why we should build tall can only make us stronger contributors. With our increasingly more pivotal role in the delivery of quality buildings with strong environmental credentials, I genuinely believe there has never been a better time to be a building services designer.

My congratulations to all on the organising committee for their hard work and dedication and long may the membership support them. You have a strong region ... work hard to keep it that way and, hopefully, I can find an excuse to visit Ireland again very soon.



Sean Barry and Willie Bennett, Winthrop Engineers with Jack Dodd, Control Technology



Patrick Kenny, McGrattan & Kenny with Niall McCaffrey, Winthrop Engineering and John Doherty, McGrattan & Kenny and CIBSE



Denis O'Neill, Building Services Engineers with Fergus Daly, Hitachi and Colin McCready, Building Services Engineers



Afternoon Session 1 Speakers and Chair — Barry Woods, Schindler Lifts with Kevin Kelly, CIBSE and DIT; Liam Murthagh, Schneider Electrical Ireland; and Terry De Lacy, Thorn Lighting



Liam Hinch, T Bourke & Co with John Furlong, CIBSE



Bartek Mokrosinski and Renata Weron, JV Tierney & Co with Anna Kosiel, Arup



Afternoon Session Speakers and Chair — Tim Cooper, Conservation Engineering with Mc ChewPieng Ryan, Buro Happold; and Joe Durkan, SEI.

Technical Fault-Finding Can Be **Murder!**

So, you've just had a hard day at work, want to put it all behind you and switch your brain off in front of the TV. There's nothing like a good old murder drama to take your mind off things, eh? But have you ever considered that you could be missing out on a training resource that's happening right in front of you?

In a somewhat tongue-in-cheek approach, John Kealy suggests that next time you're watching your favourite cop show, consider the approach that's taken by the detective involved and see if it complies with the following steps, which apply equally well to technical fault-finding in a heating system.



Step 1

Establish if there really was a crime. If the victim was a chain-smoking, 130-year old, who died on the operating table during his fifth heart transplant, the chances are there was no actual crime. Similarly, if a guy drops dead because he's been trying to push his car up a steep mountain you could have predicted a bad outcome. On the other hand, just because there's a guy standing over a body with a smoking gun in his hand it's always a good idea (if you're a professional) to make sure he wasn't set-up by someone else.

Step 2

Establish a crime scene and don't touch anything. You could

wade in to the situation convinced that you know exactly what happened and who did it but, chances are, if you don't get it right, you'll mess up any evidence that you could have collected had you adopted a more thoughtful approach. Take the time to step back and assess the situation. Granted, you may need to do one or two things immediately to preserve the scene or to make it safe, but only do the minimum required for now.

Step 3

Set the scope of your investigation. You'll need to know who the victim was, who they had been in contact with and what they were doing. You will also need to establish if there had

been any irregular interactions or behaviour recently. You might want to check out their medical history to see if they had any relevant problems and that they had been generally well looked after. Talk to witnesses about the victim's behaviour. Maybe they noticed something odd or perhaps seemingly unrelated events that coincided with the incident.

Step 4

Collect evidence and statements. Get the facts about what happened and the lead up to the event. Don't rely on witness statements unless you have fully confirmed them. You may have to ask misleading questions of the witnesses to confirm or dismiss any preliminary theories you may have. Don't forget to verify the integrity of your witnesses. Some of them may be adding extra detail or emphasis to make themselves feel significant in the case. Others may be trying to throw you off the trail intentionally because they have something to hide or couldn't be bothered spending the time talking to you. Others may have no shortage of apparently utterly-irrelevant



information. It's all good data though and you can filter out the rubbish later.

Step 5

Analyse the evidence and come up with a theory. When you have all the facts, have a think about it. This is where your knowledge and experience of these incidents comes into play. It always helps if you have a sidekick on hand to talk things over with and to enable you to step through the facts and clarify them in your own mind. You're the professional so you know how things work and you should be able to establish a clear picture of what happened in the lead up to the incident.

Step 6

Identify possible suspects. Once you have established clearly what happened and who could even possibly be involved, no matter how remotely, you have your suspects. Now it's time to work through them carefully. There's probably your old reliable ex-con with a track record that it's easy to accuse. Sometimes this works but occasionally it can go horribly wrong, with expensive and time-consuming consequences – and you still won't have caught the real criminal. Faced with a number of suspects you can always try the approach of eliminating those who couldn't possibly have committed the crime. Don't forget that you should prove to yourself that they are not

responsible and not just rely on hearsay.

Step 7

Make an arrest. You have your prime suspect, now you can really get to work substantiating your theory and suspicions. You might opt for a search warrant and investigate the suspect further. You shouldn't do this until you're pretty certain of your evidence. The only real reason to do it is to substantiate your case. Just make sure your case will stand up in court before you kick things off as it's never easy to go backwards.

Step 8

Go to trial. You've proved beyond a reasonable doubt to yourself that your suspect is guilty. Now you take it to trial and present your case. If you've got it wrong then you've clearly missed a vital clue and will have to go back to Step 4 or 5. Ideally you want the culprit to plead guilty immediately. Then everyone can go back to their normal routine and you can wallow in the afterglow for a while before moving on to your next case.

Conclusion

You might be wondering what practical use this all has for someone in the building services industry. Try this — you've just been called out to investigate why a heating system has stopped working, or is not performing as well as it used to.



Now, instead of a victim in the above steps, you have the heating system; instead of a crime you have the fault that caused the system's downfall; your witnesses are the people who reported or experienced the problem; and your suspects will include the components of your system, or any other system you consider to be involved.

So, when it comes to technical fault-finding with a heating system ... go for it Sherlock!

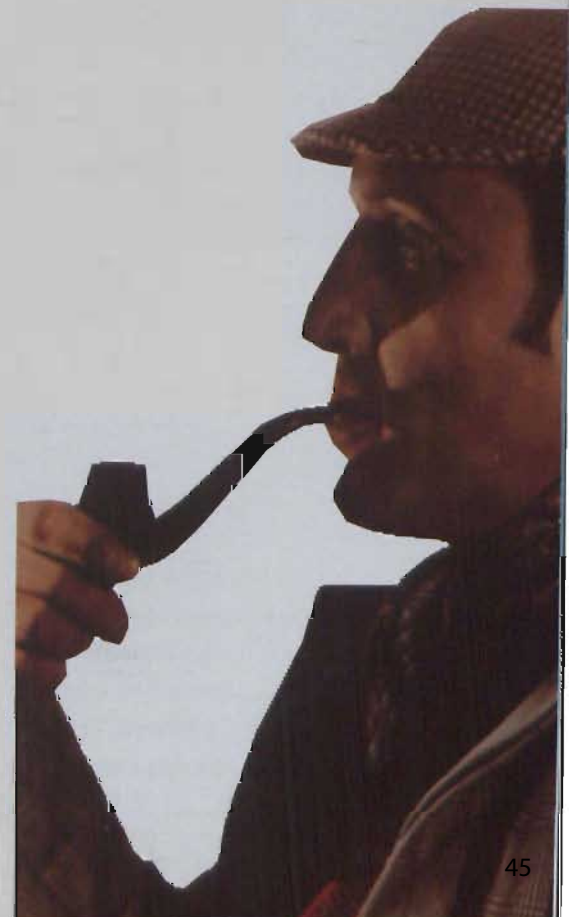

Plumb Lines

heard it on the grapevine ...



NO OIL, COAL OR GAS ... WHO CARES?

What does a country like Portugal — which has no oil, coal or gas of its own — do for energy? ... it builds the world's largest solar photovoltaic farm. Costing just over €300 million, the farm comprises 2520 giant solar panels which are the size of an average house and incorporate highly-advanced and sophisticated technology.



The farm is said to be twice the size of London's Hyde Park and by far the largest in the world. Projected output is 45MW of electricity each year, enough to power 30,000 homes.

Apart from dramatically increasing solar power generation over the last three years, Portugal has also trebled its hydropower capacity, quadrupled its wind power output, and is investing significantly in wave technology.

Even more critical still is the genuine will to push such developments through. Apparently, there is no government indecision while delays by planning law appeals are simply not tolerated. Definitely a lesson for Ireland there!

LIGHTS OUT IN NEW ZEALAND

While we here in Ireland have long since embraced a "switch-it-off" mentality, it was something of a culture shock for New Zealanders to be told to do likewise recently. Hydroelectric stations normally provide something like 75% of the country's electricity but lack of rainfall over a two-year period has reduced that output to 50%.

Households are being asked to reduce electricity consumption during early evening peak times by as much as 15%. This is a difficult enough concept for people not used to energy shortages but, coinciding as it does with the arrival of winter in the southern hemisphere, it is all the more unpalatable.

MARKET SURVEY REPORTS

BSRIA has just published its latest report — The World Air Conditioning Market in 2007. It is packed with all manner of interesting statistics and figures, not least being that the world market for 2007 was valued at US\$62 billion.

While it makes very interesting and thought-provoking reading, the downside is that Ireland is not included. BSRIA told *bs news* it does not evaluate Ireland separately in either its worldwide review format reports or its in-depth air conditioning studies. Pity that.

However, it does evaluate Ireland separately in its worldwide heating report which was released in April of this year. Moreover, Ireland will also be evaluated separately in its forthcoming heat pump reports due to be published this coming September.

As the song goes ... two out of three ain't bad.

CAR FLAGS DAMAGE ENVIRONMENT!

While we're used to so-called eco-warriors coming up with hair-brained ideas to champion the environment, it is hard to credit that engineers in Austria have declared flying miniature flags from car windows a no no.

Just days into this month's Euro 2008 Football Championships, Austria's Automobile Club condemned the practice of attaching flags to car windo frames.



Apparently, the flags alter the car's aerodynamics with two flags on a vehicle increasing petrol consumption by "up to a half a litre per kilometre travelled on rural and motorway stretches".

So, come on the Dubs ... but without the miniature car flags please!!!

RUBY CONTRACTOR TWINS!

Further to our 4-page special on T Bourke & Co last month to mark its 40 years in business, it prompted some debate within the industry as to what other mechanical and electrical contractors could claim such longevity. As it happens, McGrattan & Kenny also celebrate a ruby anniversary this year, having been incorporated on 6 May 1968. Congratulations to all at both companies.

evolution

High performance cooling/heating multi systems for retail & leisure

- Mitsubishi Heavy Industries high performance cooling/heating systems are designed for a variety of retail and leisure applications
- Simple, low cost installation
- Connect up to 4 indoor units to a single outdoor unit. Indoor units connected by branch piping, just two pipes connected to the outdoor unit
- Up to 28kW cooling or heating with an outdoor unit footprint of just 0.36sq m

New compact, high performance outdoor units with **INVERTER** technology



evolution:high performance solution



3D Air Sales (Ireland) Ltd,

Tel: 01 - 463 8604 Fax: 01 - 463 8606

Fit & Forget

Building Services Engineering, Vol. 47 [2008], Iss. 6, Art. 1

Instruments & Controls

Manotherm Ltd provides a broad range of precision instruments for measuring, transmitting and controlling pressure, temperature, level and flow. In addition to providing quality precision instruments, Manotherm is committed to exceptional customer service, including knowledgeable, courteous technical support that generates and maintains long-term relations.

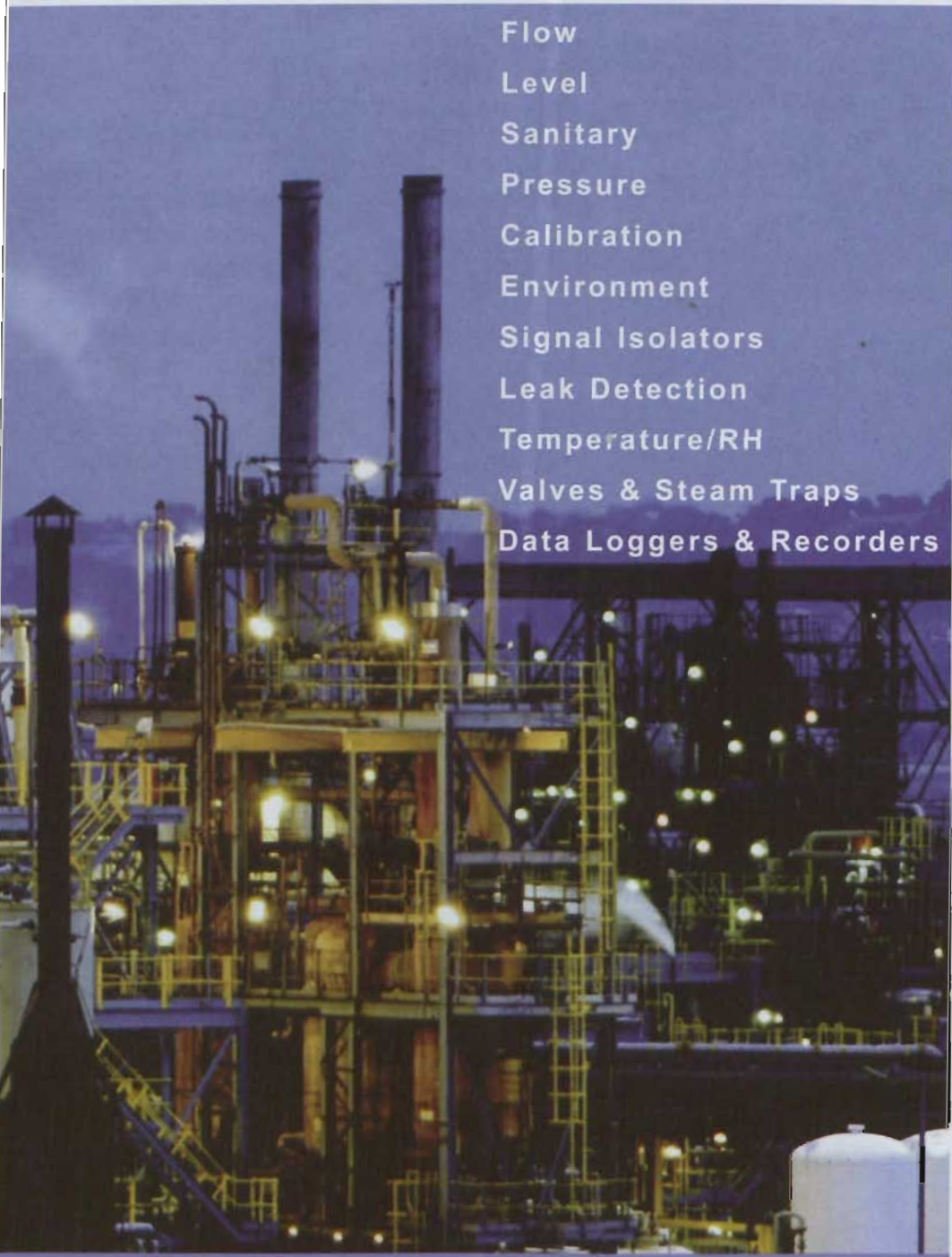

- Flow
- Level
- Sanitary
- Pressure
- Calibration
- Environment
- Signal Isolators
- Leak Detection
- Temperature/RH
- Valves & Steam Traps
- Data Loggers & Recorders

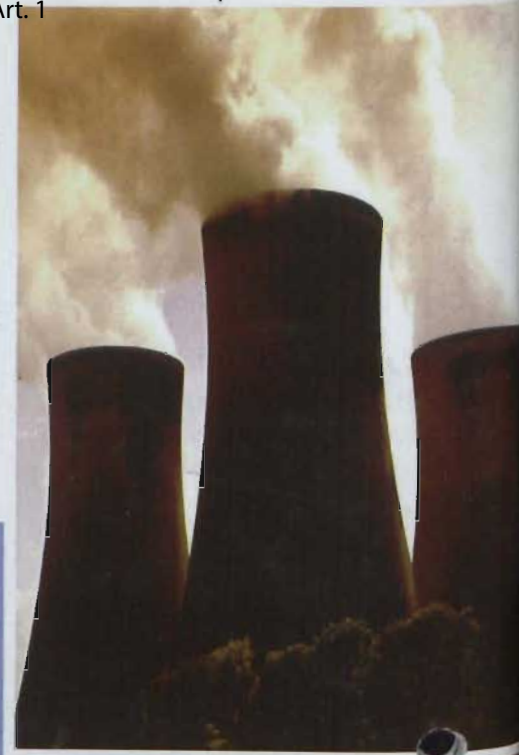

The Controls Centre,
4 Walkinstown Road, Dublin 12.

Tel: 01 - 452 2355/452 2229

Fax: 01 - 451 6919

<https://arrow.tudublin.ie/bsn/vol47/iss6/1>

email: info@manotherm.ie

web: www.manotherm.ie