

12-1-2002

BS News

Follow this and additional works at: <https://arrow.tudublin.ie/bsn>



Part of the [Civil Engineering Commons](#), [Construction Engineering Commons](#), and the [Construction Engineering and Management Commons](#)

Recommended Citation

(2002) "BS News," *Building Services Engineering*: Vol. 41: Iss. 10, Article 1.

Available at: <https://arrow.tudublin.ie/bsn/vol41/iss10/1>

This Article is brought to you for free and open access by the Journals at ARROW@TU Dublin. It has been accepted for inclusion in Building Services Engineering by an authorized editor of ARROW@TU Dublin. For more information, please contact arrow.admin@tudublin.ie, aisling.coyne@tudublin.ie, vera.kilshaw@tudublin.ie.

BSN News

MECHANICAL & ELECTRICAL BUILDING SERVICES

THE OCCUPANCY STUDY PROCESS



DEFINITION OF THE BRIEF



DEVELOPING SOLUTIONS

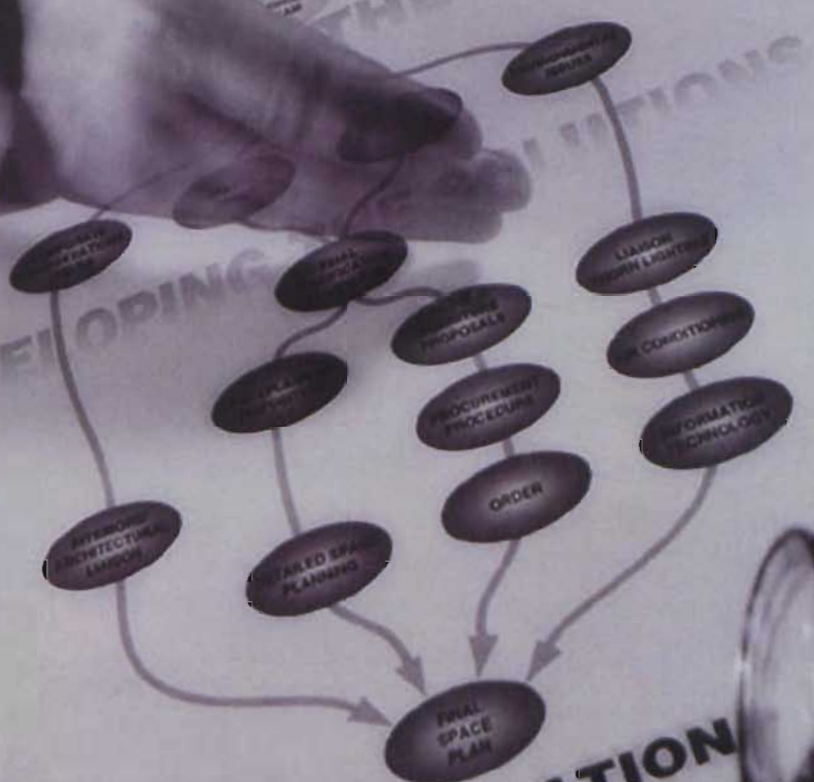

INSTALLATION

**Instruments & Controls
Radiators & Thermostats**

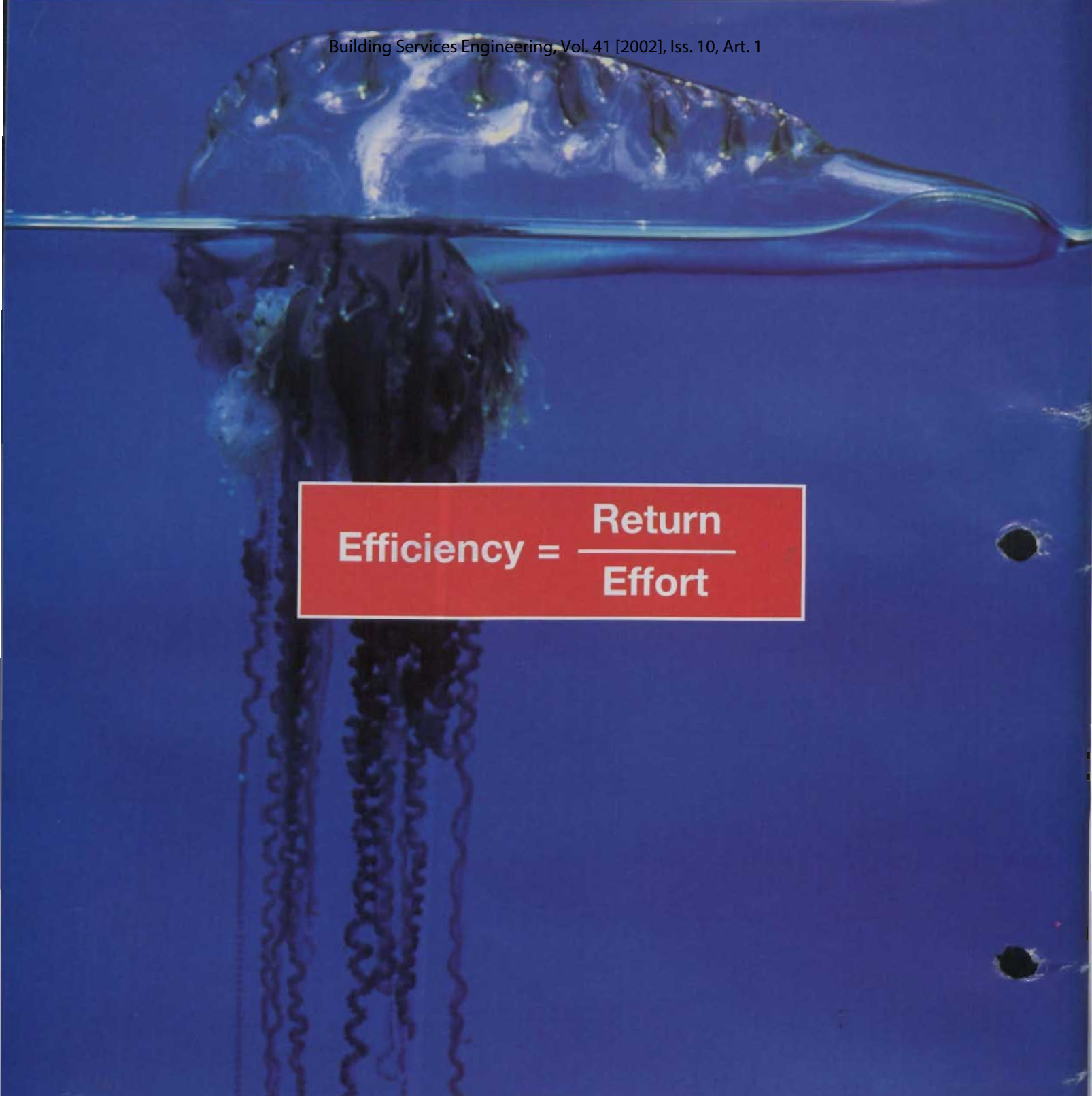

$$\text{Efficiency} = \frac{\text{Return}}{\text{Effort}}$$

The more intelligent system wins.

With its shimmering blue, bladder-like body, the umbrella-shaped Portuguese man-of-war glides gracefully into the wind. And hidden below the water, the highly-poisonous tentacles of the jellyfish can reach as far down as 50 metres towards the ocean floor in order to ensnare the creature's prey. Without using any muscle strength whatsoever, the animal can travel as fast as ten kilometres an hour, a record for the jellyfish species.

Mother Nature demands top performance at all times in all places while expecting, at the same time, the lowest energy consumption. This is the ambitious goal that WILO also aims at in its research and development programmes. With its high-efficiency pump, Stratos, WILO has introduced a new yardstick.



Experience the technology of the future. The Wilo Stratos pump saves up to 80% of energy. It heralds the beginning of a new era of pumps, the generation of the high-efficiency pumps. Place your order for the High Efficiency folder with its wealth of information. And on Wilo's «Green Pages» on the Internet, you can find a list of qualified High Efficiency engineers and analysts.

Further details can be obtained from:

Phone: 061-410963

Fax: 061-414728

www.high-efficiency.com



Twice the efficiency!
Up to 80% less energy consumption!

Pumping Perfection
and more...



BSNews

MECHANICAL & ELECTRICAL
BUILDING SERVICES

ISSN 0791-0878

Published by:
Pressline Ltd,
Carraig Court,
George's Avenue,
Blackrock, Co Dublin.
Tel: 01-288 5001/2/3 Fax: 01-288 6966
ISDN: 01 - 211 2338/9
eMail: bsnews@pressline.ie
Website: www.buildingservicesnews.com

Editor: Pat Lehane
Advertisement Director: Joe Warren
General Manager: Louise Byrne

Production and Design:
Pressline Ltd. Tel: 01 - 288 5001

Subscription: One Year —€45

Printed by: Kilkenny People Printers.

© All editorial contents and all advertisements prepared by the publishers, Pressline Ltd.

* Incorporating Irish Heating & Ventilating News.

Readership Data

Irish Building Services News (formerly Irish H&V News) is Ireland's only Building Services magazine providing coverage of heating, ventilating, air conditioning, refrigeration, sanitaryware, plumbing, maintenance and environmental industries. It is the only publication catering exclusively for these industries and its circulation includes members of

including:-
Chartered Institution of Building Services Engineers (CIBSE); The Mechanical Engineering & Building Services Contractors' Association (MEBSCA); The Association of Consulting Engineers of Ireland (ACEI); The Mechanical Engineering Contractors' Association; The Institute of Domestic Heating Engineers (IDHE); The Registered Heating Contractors Association; The Maintenance, Energy & Environmental Technology Association (MEETA) which incorporates energy managers and maintenance managers; The Energy Conservation & District Heating Association; The Institute of Plumbing; The Irish Home Builders Association (IHBA); Builders Merchants/Trade Supply Outlets; Irish Property & Facilities Managers Association.

In addition, Irish Building Services News circulates to independent building services contractors and key executives in industry, Government, Semi-State and local authority bodies. Essentially, our circulation is virtually saturation coverage of all those with an interest and/or involvement in the industry.



We wish all our readers and advertisers a very peaceful and enjoyable Christmas, and a prosperous New Year. As always, rather than send Christmas cards and gifts to clients at this time, BSNews makes a donation to the three registered charities — Simon Community, Goal and ActionAid.

I N T H I S I S S U E

Trade News & Product Information	2
CIBSE News	12
Property & Facilities Management	14
SEI Call for Submissions on Energy Agreements	17
Instruments & Controls	20
Air Enterprises Europe Launch	27
Radiators & Thermostats	30
Breakthrough in Energy Saving From Nuaire & Redbro	48
Wilo Turns To Nature For Solutions	50
BTU Results From Royal Dublin	52
RECI Celebrates 10 Years!	54
Trane — Quatum Leap Forward in AHUs	55
Grundfos — Wastewater Lifting Solutions	56

Danfoss & Saginomiya in Joint Venture

Saginomiya Seisakusho, Inc. and the Danfoss Group have signed a joint venture agreement as the initial step in what the two companies hope will grow into a global cooperation of their refrigeration and air conditioning controls activities. The headquarters of Saginomiya and Danfoss are based in Japan and Denmark respectively. Saginomiya is the market leader on the Asian market, while Danfoss is the market leader on the European market. Both companies operate globally and share many common values.

The joint venture will establish a company in Poland, Danfoss Saginomiya Sp. z o.o., which is equally owned by Saginomiya Seisakusho, Inc., and Danfoss A/S, according to the terms of the agreement. Danfoss Saginomiya Sp. z o.o. will be responsible for distribution of Saginomiya's refrigeration and air conditioning controls programme to the European market. In addition, the company will manufacture and distribute cartridge controls (disc type small pressure controls) for the air conditioning industry in Europe on the basis of a license from Saginomiya. The new company will

be based at the Danfoss factory in Grodzisk Mazowiecki, Poland. Mr Viggaard from Danfoss has been appointed president of the company and Mr Setsuda from Saginomiya, is responsible for sales management.

"Saginomiya and Danfoss share a vision of an expanded cooperation of their refrigeration and air conditioning controls activities", says John Sampson, Managing Director, Danfoss Ireland. "There are, however, no specific plans for further activities yet, as future plans will be developed in accordance with the experiences the present joint venture will generate.

"The two companies complement each other very well and, when we combine our strengths, both will become stronger for the benefit of our customers. We expect the increased application know-how and complete product programme to enhance customer satisfaction. Creating added value for customers is a main priority, as well as producing high-quality products while, at the same time, ensuring environmental protection".

Contact: John Sampson, Danfoss Ireland.
Tel: 01 - 626 8111.

Wavin Opens New €3.2m Extension



G.V. Wright, TD, with Michael Kennedy, Cathaoirleach, Fingal County Council; Martin Cullen, TD, Minister for the Environment and Local Government, and Larry Carr, Managing Director, Wavin Ireland

A €3.2 million extension to Wavin Ireland's main extrusion plant in Balbriggan, Co Dublin was officially opened by the Minister for the Environment and Local Government, Martin Cullen, TD, in late November. The new facility significantly extends Wavin's production capability and considerably improves productivity.

Additionally, Wavin used the occasion of the official opening ceremony to mark the 40th anniversary of the Balbriggan plant, and also the introduction of a new corporate identity for the Wavin Civil Engineering Division.

Contact: Larry Carr, Wavin Ireland.
Tel: 01 841 5000.

AcTech Wins Major Contracts

AcTech Europe Ltd has recently been awarded the design, manufacture and installation of several prestigious contracts including:- Dell Computers; ESB (Castlebar and Baldoyle); Ballyfermot Senior College; Swords Laboratories; and the Gaiety Cinema Complex, Sligo. AcTech's aim is to provide a complete

acoustic package from the initial design and testing through to installation and commissioning of contracts. AcTech Europe Ltd offers a one-stop-shop custom acoustic solutions to suit individual requirements.

Contact: Brian Topping, AcTech.
Tel: 045 - 851 500;
email: sales@actech-

Futuristic Cabinet AC From Core

Core Air Conditioning, Haier's distributor for Ireland, has selected the most appropriate products for the Irish market from the vast range available. A typical example is the Haier range of futuristic-looking cabinet air conditioning models (see right). Benefits include interconnecting pipework of up to 50m; Copeland scroll compressors; Outputs from 5kW to 12kW; Easy service access; R407C refrigerant; Full fault diagnostics; 15m air throw on maximum

speed (HPU-44); Infrared and touch pad control; Fresh air inlet option; Automatic air flow adjustment; Quiet operation; 24-hour timer. Haier is the fifth largest manufacturer of consumer goods in the world. Last year it produced 5.8 million air conditioning units, enough to supply the entire European market nearly three times over. Its products are sold in over 90 countries with worldwide sales of approximately e7.2 billion in 2001. New products are

produced at a rate of 1.3 per day with an average of 2.5 patents per day being registered. All are manufactured to the most stringent quality control standards and comply with all relevant national and international certification and standards.

Contact: Austin McDermot/Andrew McEvitt, Core Air Conditioning.
Tel: 01 - 409 8912;
email: info@coreac.com

The futuristic-looking Haier cabinet air conditioner from Core Air Conditioning



AMBIRAD

Space Heating & Building Temperature Control Solutions From One Source

heatmiser[™]
Effective Temperature Control



For complete catalogue information, technical support, or for an immediate quotation contact:

Thermelec Ltd, Old Naas Road, Bluebell, Dublin 12
Tel: 01 - 456 8111; Fax: 01 - 456 8108; email: sales@thermelec.ie

THERMELEC

Sanyo Welcomes 2003 With a Smile of Confidence

Sanyo are looking forward to welcoming in the New Year after a fantastic 2002. Last summer saw the launch of the Direct Sales Operation in Dublin in response to strong growth in Ireland, and since then it's just been one great success story. In a period of economic unrest Sanyo chooses to adopt a positive outlook. Sanyo Ireland's Sales Manager, Barry Hennessy, has plenty to smile about this Christmas. "Our target was to get things moving in the Irish market and we have certainly done that." When we launched the direct operation we expected to see phenomenal growth and we haven't been disappointed. What is probably more pleasing is that we can also add

value to the market and next year will see us introduce methods of increasing the penetration of air conditioning into new fields."

The company has had some major wins in recent months, such as an office installation in Parnell Street that includes over 60 Eco Multi VRF outdoor units, and good progress has been made towards the development of a dedicated dealer network with the appointment of four dealers so far.

"We now have the right team in place to deliver the strengths that people quite rightly associate with Sanyo: Quality, flexibility and reliability." Says Barry. "I can't say too much at present but negotiations are continuing to



Barry Hennessy, Sanyo's Sales Manager in Ireland

complete our dealer line-up and I'm looking forward to adding to the Sanyo team too in the New Year.

"I'm also excited about our new products for 2003. We'll be launching new multisplits and later on in the year our gas engine heat pump. By using natural gas as an energy source it dramatically reduces running costs plus enables air conditioning to be installed where previously it was impossible. I think that is going to really be hugely significant — it's bound to have a big impact.

"Sanyo is the fastest growing Japanese air conditioner manufacturer in the world, and with the right people and excellent product availability from our Dublin warehouse, there's every reason why 2003 is going to be just as successful. Personally, I hope to put a bit of the pleasure back into our business with sporting dinners and events on the agenda," says Barry. Contacts: Barry Hennessy, Sanyo Air Conditioners. Tel: 01 - 456 8910; Web: www.sanyoaircon.com

Bluebox Appoint Walkair



Bluebox ... now available from Walkair

Bluebox Group has appointed Walkair Ltd as sole distributor for its range of chillers, packaged rooftop units, and fan-coil units. Walkair already holds a number of other air conditioning franchises, the composition of the portfolio being carefully designed to match "niche" market requirements. Bluebox Group is a well renowned and established manufacturer of air conditioning products. The portfolio includes fan coil units with nominal duties from 1kw to 49kw, packaged rooftop units from 5kw to 240kw, and

chillers to 1200 kw. Walkair has recently supplied and commissioned Bluebox units to a number of critical applications for Siemens Medical. Vincent Mahony, Sales Director for Walkair said: "This is a very exciting opportunity for Walkair and Bluebox. Combined with our other franchises, for example Panasonic multi-split systems, Marley Cooling Towers etc, we can now offer customers a complete package for all their needs." Contact: Vincent Mahony, Walkair. Tel: 01 - 456 8070.

NOW AVAILABLE

NEW 110-PAGE VENTAC PRICE LIST

Our most comprehensive ever

Covering our stock range of Fans; Grilles/Diffusers; Attenuators;
Flexible Ducting; Spot Extract Arms; Etc

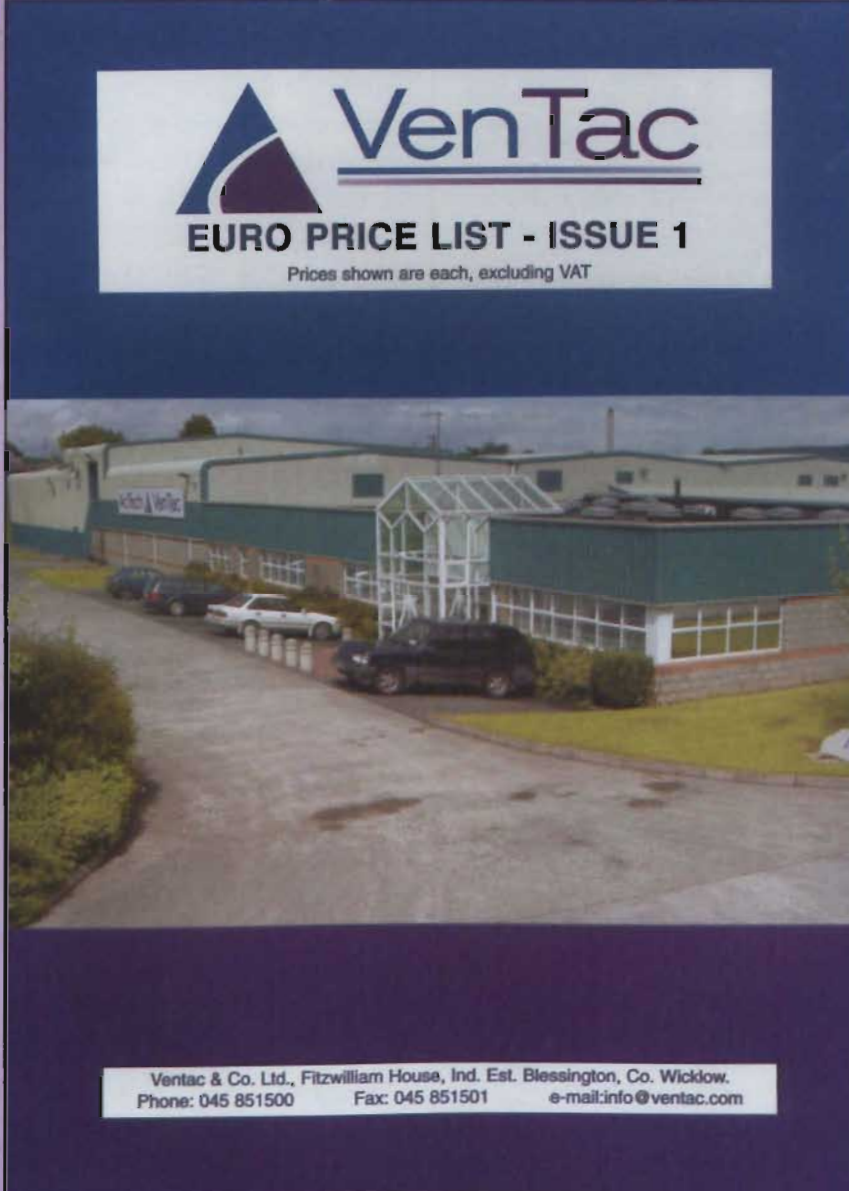

VenTac
EURO PRICE LIST - ISSUE 1
Prices shown are each, excluding VAT

VenTac & Co. Ltd., Fitzwilliam House, Ind. Est. Blessington, Co. Wicklow.
Phone: 045 851500 Fax: 045 851501 e-mail: info@ventac.com

Also available:
272-page Fan Selection Manual
&
VenTac Technical Binder on CD-Rom

TO ORDER YOUR COPY EMAIL YOUR REQUEST TO MMORAN@VENTAC.COM

VenTac & Co Ltd, Fitzwilliam House, Industrial Estate, Blessington, Co Wicklow
Tel: 045 - 851 500 Fax: 045 - 851 501 email: info@ventac.com

Two-Stage Short Cased Axial Fans



The new 2-stage short-cased axial fan range is now available from VenTac

VenTac has increased its comprehensive stock range of fans with the recent addition of the new 2-stage short-cased axial range. These units are now available and proving very popular. They are available in four sizes — 450mm ϕ , 500mm ϕ , 560mm ϕ and 630mm ϕ — and are capable of achieving duties of up to 18,000 m³/hr with pressures of up to 700 Pa. While achieving considerable duties, they also have the advantage of being very slim with maximum flange-to-flange dimensions of 520mm. They are also suitable for speed control, are suitable for temperatures from -40 to +70°C, and are considerably quieter than any similar unit currently available. According to Mark

Moran at VenTac: "They are proving very popular with contractors. They give fantastic performance at a fraction of the price of standard 2-stage axials or even centrifugals. Their small size allows them to be accommodated in even the most restricted of installation arrangements. "Their steep performance curve is also very forgiving. In the event that the pressure drop of a duct run has been underestimated, there is usually bags of pressure available to overcome additional resistance with a minimal reduction in volume flow rate."

Contact: Mark Moran, Sales Manager, Ventac & Co. Tel: 045 - 851500.

World Plumbing Conference

Contrary to the information contained in last month's issue of *BSNews*, the next World Plumbing Conference will take place in Auckland, New Zealand.

Contact: www.worldplumbing.org

New MD at Alma Engineering

Alma Engineering Supplies Ltd has appointed Andy Kidd Managing Director of the company. Andy has been with Alma Engineering for nearly 20 years and his appointment will guarantee continuity and development within the firm. Another recent appointment is that of David Holmes to the position of Sales Manager in Alma Engineering. David comes with an extensive knowledge of the heating and HVAC industry, having most recently worked with Danfoss Ireland.

Contact: Andy Kidd/David Holmes, Alma Engineering.

Tel: 01-295 8257; email: almaeng@indigo.ie



Andy Kidd, Managing Director and David Holmes, Sales Manager, Alma Engineering

Rejuvenated IDHE Looks to 2003

The process of rejuvenation and reorganisation at the IDHE is now almost complete, the dynamic new programme planned for the coming 12 months scheduled to commence early in the new year.

Over the last few months the Committee has worked tirelessly to

put the new programme in place and 2003 will see the profile of the Institute raised considerably, both on the education front and in respect of general industry matters.

Contact: Joe Newman, Hon Treasurer.
Tel: 087 245 7729.



Celebrate 2003 with our cracking new products!

With the new R407C cooling-only splits, R410A multi-splits, an upgraded cassette and the introduction of the Sanyo Gas Engine Heat Pump, the 2003 Sanyo line-up just goes from strength to strength.

Sanyo Air Conditioners, 41 Western Parkway Business Centre,
Ballymount Rd, Dublin 12 Tel: 01-4568910 Fax: 01-4507227

Published by ARROW@TU Dublin, 2002

SANYO
AIR CONDITIONERS

www.sanyoaircon.com

Homan O'Brien Move to Booterstown

Homan O'Brien Associates have moved to new, purpose-designed premises located at 89 Booterstown Avenue, Blackrock, Co Dublin. Built by P Brock & Son, fit-out design was by Burke

Kennedy Doyle with the official opening performed by Duncan Stewart.

The construction and fit-out of the 6500 sq ft offices reflect the ethos of Homan O'Brien, especially in respect of sustainable engineering design. Hence the use of the exposed concrete structure's thermal mass to stabilise the internal environment; the introduction of supplemental fresh air through the new raised access floor; the extraction of air through automatic temperature-controlled louvers in continuous roof light; and the automatic light control system incorporating daylight control.

Contact: Brian Homan or Simon O'Brien.
Tel: 01 - 205 6300.
email:
infor@homanobrien.ie



Kevin Porter with David Kelly and Eamon O'Brien



Brian Homan with Duncan Stewart



David Corrigan with David Browne and Kevin Kelly



Colin Murphy with Joe Melvin and Pat Walsh

CIVILEX 2003

CIVILEX, Ireland's dedicated civil engineering show, is back at the RDS, Dublin on 11 & 12 February 2003.

As well as providing a dynamic forum for visitors to meet the industry's top suppliers and learn about new and innovative products and services, Civilex 2003 will host a series of key seminars, presented by industry experts.

Topics on the programme include:

- Contractor certification of design-and-construct projects;
- An integrated management system for commercial, quality, environment, health and safety matters;
- Mediate more and litigate less — a UK perspective;
- Sustainable technologies, their role in regeneration.

Seminar places can be booked by contacting Diane Lewis at Thomas Telford Training.
Tel: 0044 20 7665 2457
email: training@thomastelford.com.

Buderus GB112 Series Wall-hung Condensing Boilers



Range 24/29/43/60kW



Unit L40, Cherry Orchard Industrial Estate,
Dublin 10

Tel: 01 - 630 5757; Fax: 01 - 630 5706

Web: www.cfquadrant.ie

Buderus

DON'T REPLACE

A TRADITIONAL PUMP

NOT JUST A PUMP – A NEW STANDARD

Grundfos Alpha is something of a revolution. A major breakthrough in automatic controlled circulators. A pump that pumps when necessary – otherwise not. Some call it intelligent. We call it reduced power consumption, a better environment, less radiator noise, faster installation. Get ready for a new standard!





UPGRADE

TO AN EASY TO INSTALL, FASTER MODEL

Visit to Fingal CC Offices



Some of the participants in the recent CIBSE site visit to Fingal County Council Offices in Swords



Chris Corwley with Dave Brennan; Kevin Tracey, CIBSE Vice-Chairman and Society of Light & Lighting Representative; Brian Sterling, CIBSE Chairman; Barrie Wilde, President, Society of Light & Lighting; and John Doyle

There was an excellent turnout for the CIBSE visit to the Fingal County Council offices in Swords recently.

Members and guests gained an in-depth understanding of the building services installation in the complex and were royally hosted by Fingal County Council and Building Design partnership.

To begin with, Barrie Wilde, President of SSL (The Society of Light and Lighting) delivered the ironically-named "Afraid of the Dark" lecture to students at DIT, Bolton Street, while Light, Lighting and Engineering Services provided the focus for the "walkabout" seminar at Fingal County Council Offices in Swords later that evening.

The Offices Building emerged from a client

brief which included the need for "an open and transparent expression of local government" and is widely judged as reflecting a literal interpretation of the brief, delivering "green" and sustainable engineering.

The M+E engineering team involved on the design brought the participating group around the offices and explained the various engineering systems and lighting solutions. The seminar proved very interesting and stimulating for all participants. CIBSE and SSL are grateful to BDP (Building Design Partnership) and Fingal County Council for hosting the event.

Forthcoming CIBSE Events

Electrical Power Distribution	Declan Devlin & Tony Delaney	Burlington Hotel	16th January 2003
Testing of Buildings for Air Tightness	BSRIA.	Burlington Hotel	30th January 2003
CIBSE Annual Dinner	Brian Sterling Tel: 01 - 626 1144 email: bsterling@llynch.com	Burlington Hotel	21st February 2003
Lighting Seminar (Full Day)		IEI, Clyde Rd	27th February 2003
Advanced Fire Systems Design & Requirements		IEI, Clyde Rd	13th March 2003
Annual Students Award		DIT, Bolton Street	20th March 2003
Annual General Meeting		IEI, Clyde Rd	10th April 2003

(Seminar venue and dates subject to confirmation by correspondence to Members)

UNIPIPE®



One pipe for all services 12 to 110mm

Plumbing • Radiators • Floor Heating • Compressed Air

Unipipe (Irl) Ltd,
40 Southern Cross Business Park,
Boghall Road, Bray, County Wicklow
T: 01 2864888 - F: 01 2864764
E: info@unipipe.ie



- **Unipipe (by Uponor) multi-layer pipe offers a proven alternative to steel, copper and plastics for mechanical services.**
- **Available in straight lengths (all sizes 12 to 110mm) and coils (to 32mm).**
- **Corrosion proof, faster, cleaner. No welding screwing or painting. Longer lasting and lower installed costs**
- **One pipe...no waste...offcuts from one application can be used elsewhere on the job**
- **Unipipe provide a specialist design service for floor heating, heat-pumps and plumbing**
- **From Sweden NIBE offer both ground-source and exhaust air heat pumps.**



Unipipe Floor Heating

www.unipipe.ie

Distributors for: **UNIPIPE**  **NIBE**



120 kW NIBE Ground Source Heat Pump Installation



NIBE Heat Pumps from 3 to 300kW



Uponor Energiesysteme Ground Loop & Borehole Collectors



Preparation for Christmas Wear & Tear

The Ilac Centre was constructed in 1981.

While it is one of Dublin's oldest shopping destinations, it also remains one of the busiest. It attracts over 13 million shoppers a year and would expect to attract around 600,000 shoppers during Christmas week. The pressure this exerts on the building and its systems is immense and requires a great deal of preventative maintenance and planning to ensure operational efficiency. This intensity of use also creates some operational complexities that are probably unique to shopping centres during peak trading periods, writes *Andrew Diggins, Centre Director, ILAC Centre, Henry Street, Dublin 1.*



*Andrew Diggins,
Centre Director,
ILAC Centre,
Henry Street,
Dublin 1.*

Preparation for Christmas begins in earnest in August each year. The informal date for the start of the retail Christmas season is 1 November. This means that all of the planning and most of the preparation have to be completed by this date.

Key systems are comprehensively serviced throughout September and October to minimise operational problems during peak periods. The heating, ventilation and cooling of the

building require the use of thermostatic control managed by the building management system. However, the process also requires human intervention due to the complexity of climates that arise.

Consider this typical scenario during Christmas week. Picture a cold, sunny winter's morning. It is 10am and all doors are closed, the centre is relatively quiet in terms of customers and the heating system is on. Our aim is to maintain a mall temperature of around 15-18 °C in line with CIBSE (Chartered Institution of Building Services Engineers) recommendations. However, over the space of an hour, the centre can go from being virtually empty to virtually full. The centre experiences heat gain from the customer's bodies, solar gain through the glass roof and stored heat from the heating system itself. To maintain a comfortable mall temperature, the heating system switches off and the ventilation system attempts to provide adequate fresh air.

However, when you consider the CIBSE recommendations suggest a fresh air requirement of 8 litres per second per person and we may have somewhere around 13,000 people in the building, that is a lot of air. To assist the

A Quantum Leap Forward from The World's Largest AHU Manufacturer

- ▶ Airflows up to 30m³/s
- ▶ Unique Rigid Framework
- ▶ Low Leakage Design
- ▶ Cold Bridge Free
- ▶ Factory Engineered Controls



NEW

Quantum Climate Changer from





“Over the space of an hour, the centre can go from being virtually empty to virtually full. The centre experiences heat gain from the customer’s bodies, solar gain through the glass roof and stored heat from the heating system itself. To maintain a comfortable mall temperature, the heating system switches off and the ventilation system attempts to provide adequate fresh air.”

process, we have to pull back all doors to maximise natural ventilation and may also have to switch on the air conditioning system to cool the air to more comfortable temperatures.

Like all buildings, the shopping centre goes through a process of preventative maintenance on its gutters and drains before winter sets in. However, particular attention is paid to the soil and waste pipe systems, both internally and externally, to ensure they are checked for cracks, leaks, defective joints and of course, blockages. The centres public toilets will be used by one person every 20 seconds during peak trading periods and so we can’t afford breakdowns in this sensitive area!

Most buildings that are considered medium to large capacity electricity consumers will make efforts to reduce electrical consumption between 5pm and 7pm to avail of the Winter Demand Reduction Incentives. We also try to minimise consumption during this period using the building management system, which timetables systems to go off before 5pm. Unfortunately, the old stand-by generator the centre has is not sufficiently reliable to use on a consistent basis to reduce the load.

However, we have particular difficulties not common to other buildings during the Christmas period. Our trading hours increase to accommodate late night trading every day and all day Sundays.

A more particular problem that always causes difficulties is the provision of Christmas decorations. Trends in decorations mean that decorative schemes are now moving away from traditional elements such as foliage toward light-based schemes. For example, the scheme designed for Ilac this year features light chain grids at entrances, light chain banners with fall snowflakes around the malls, and an animatronic singing Christmas tree with Penguins as the central feature. This fantastic visual feast uses a 200-amp load on top of the existing electrical load of the centre. This means that new boards are required to supplement existing so that sufficient capacity is available safely.

The decorations also cause additional headaches in recent years that were not given much consideration in the past. Health and Safety guidelines now dictate that we must weight test the overhead supports for the ceiling decorations. The decorations

themselves must be fire retardant or self-extinguishing to be used in the centre.

Centre Staff undergo refresher training in first aid, fire safety and emergency procedures prior to the commencement of the busy season. Additionally, we carry out a safety audit with representatives of security, cleaning staff and the maintenance staff to establish any items that could cause a safety issue. For example, this year we are resurfacing the ground outside our main entrance area as indentations and subsidence caused by heavy vehicles have left the area uneven and a tripping hazard for customers. We have also improved the illumination of the street around the building, including during the periods in which we are closed. It is not uncommon in the industry for individuals to claim to have fallen and injured themselves on Centre property outside trading hours due to poor lighting. The building will be closed for Christmas day, Stephens’s day and New Year’s day this year. We expect that in the next few years, we will only close Christmas day. The intensity of use of shopping centre buildings is quite unique, particularly over the Christmas period – and this will only increase into the future.

In October 2000 the government outlined its plans for meeting Ireland's commitments within the Kyoto protocol aimed at limiting the growth of greenhouse gases. The *National Climate Change Strategy* proposes a comprehensive range of actions in all sectors, including industry and commerce. Now Sustainable Energy Ireland (SEI) is implementing a pilot project testing out approaches to negotiated energy agreements with industry. One of these, a draft agreement on boilers and heat distribution, is to involve dialogue with suppliers of boilers and related equipment and services. If successful, the pilot project could have a significant impact on the market.

Ireland's commitment to Kyoto

Within the framework of emissions agreements drawn up by the EU to meet its commitments within the Kyoto Protocol to stabilise greenhouse gas emissions, Ireland has an obligation to limit its growth of greenhouse gases to a 13% increase by the end of this decade, compared with 1990 levels. Given the dramatic growth rate in Ireland during the second half of the 1990s, this is a tough challenge: indeed, we have already

Negotiated Agreements Focus On Thermal Energy Reduction



significantly exceeded this increase, and we now face an uphill battle not only to stabilise emissions but to reduce them, while not interfering with competitiveness or economic growth.

The Irish government's *National Climate Change Strategy* outlines a comprehensive set of measures aimed at achieving the Kyoto commitment. It addresses all sectors, including industry and commerce. Most of the measures concern the generation and use of energy, since carbon dioxide is the number one culprit in relation to global warming, and since so much of Ireland's energy is generated by burning fossil fuels. Since its publication, a Cross-Departmental Climate Change Team has been established at a senior policy level, and a great deal of work has been underway behind the scenes. The Kyoto

Protocol targets are not negotiable, and there is a determination that Ireland will meet them.

Negotiated agreements and a focus on thermal energy

One of the measures included in the Strategy is a set of negotiated energy agreements to be concluded with industry. It is envisaged that these will be introduced in parallel with a new carbon tax. The idea is that companies which sign up to such agreements and meet their obligations within them will be able to claim back a significant proportion of their carbon tax bills. Within this broad framework, there is a variety of different approaches. Potentially, agreements can be negotiated with individual companies, in the case of exceptionally large energy users, or with groups of similar companies where appropriate. A third possibility is the

development of agreements which focus on one specific energy end use or technology, such as steam and hot water boiler installations. Negotiated energy agreements have been in place for some time in other countries, including the UK, Denmark and The Netherlands. A carbon tax/negotiated agreements package has just been announced for New Zealand, where the tax will be levied at US\$12 per tonne of carbon dioxide equivalent and where, as in the UK, participation in negotiated agreements may lead to rebates of up to 80% of the tax liability. The level of any similar tax regime here, or the amount of any rebate, are not yet known. Negotiated energy agreements sound simple – the agreement is that the participants undertake actions that will reduce their energy-related emissions by an agreed amount in return for tax rebates. But there are many different options, and the task of developing a set of agreements that will deliver what is expected of them in an efficient manner is by no means straightforward. For this reason Sustainable Energy Ireland embarked earlier this year on an 18-month pilot project aimed at the development of draft agreements with industry. In fact, the project entails the development of three different types of negotiated agreement. One of these will be with

a single large company; another will be with a small group of companies from the same sector; and the third focuses specifically on thermal energy.

From its experience in working with companies in relation to thermal energy – hot water and steam boilers, and heat distribution – SEI is well aware that there are very significant savings in energy and related emissions to be gained in this area. An agreement relating to thermal energy is potentially open to companies of all sizes and from all sectors to join. The pilot project involves groups of companies from the industrial sector (plus a few large services organisations), which have agreed to work with SEI on the development of draft negotiated energy agreements. These agreements will not be binding – they could not be, ahead of the introduction of a carbon tax – but they should provide a blueprint for the different kinds of agreement that might be concluded in Ireland. The project, which started in early 2002, will be completed in mid-2003, and it is hoped that it will clarify many aspects of a simple but effective scheme of agreements suitable for Ireland.

The thermal agreement

The thermal agreement 'strand' of the pilot project involves 15 companies working closely with SEI. It will include hot water and steam boilers, plus heat distribution. Use of thermal energy in actual



production processes will not be included. The idea is that the working group will develop a 'pro-forma' agreement covering these areas, and that such an agreement would then be available for all companies to sign up to, no matter what their sector or size. Thus, the agreement could represent an "off-the-shelf" package quickly available across the industrial and commercial sectors, and would avoid the need for companies to be directly involved in a costly and lengthy negotiation process. Such an approach could be appropriate particularly where firms' energy bills are relatively small and may not

warrant a major investment up-front in negotiating a special agreement. If successful – and this would represent the first time such an agreement had been put in place in any country – it could have a rapid uptake after the introduction of a carbon tax/negotiated agreements package. The 15 companies participating in the development of the draft thermal agreement will each undergo a thorough energy audit of their thermal installations, carried out by an external energy auditor against an audit specification being commissioned by SEI. It is expected that the audits will be concluded in the

first months of 2003.

From these audits, a list of potential actions will be developed, with the aim of ensuring that participating companies will bring their installations and management systems up to international best practice. This list of actions will be negotiated with the group of companies in the spring of 2003.

IBEC is also represented in the project, as there is a need to ensure that the draft agreements will provide for a reasonable arrangement which can be available to as broad a cross-section of industry as possible.

A role for suppliers?

It is clear that such an agreement could have a considerable impact on the market for boilers and ancillary equipment, and for the service industry. It should create a demand for energy-efficient installations and for improved boilerhouse and energy management. For this reason alone it is important that the supply side should be aware of the project and its potential impact. But there is a further possibility in relation to an agreement aimed at a specific technology or end-use. The supply side itself could support such an agreement in some way. For example, there might be an agreement to provide training, information and other supports to boiler operators that would assist in raising the energy efficiency of installations. There could

be special promotional campaigns. Another possibility would be that suppliers and servicing companies would specify best international practice in relation to thermal energy efficiency, wherever possible. Ultimately, there might be movement towards adoption of a code of practice that would ensure the most energy efficient installations possible. A variety of different options might be incorporated into an actual negotiated agreement, and the pilot project will explore the possibilities, through dialogue with interested parties.

Initiation of a consultation process

For suppliers, then, the project offers an opportunity to help develop optimum packages of support in raising levels of energy efficiency in this important area. In order to initiate a process of consultation with suppliers of steam and hot water boilers and related equipment and services, Sustainable Energy Ireland is now inviting submissions from interested parties (see advertisement, page XX). These submissions should focus on the possibilities for suppliers to support a negotiated energy agreement on thermal energy, and perhaps on the possibilities for

suppliers to join a related agreement to support the participation of industry in a negotiated thermal energy agreement. SEI will compile submissions into a paper which will be circulated to all who have contributed suggestions and views. This paper will be used for further consultation with suppliers, and will form the starting point in a dialogue which should end with a consensus view on what packages of support could be offered to operators of boilers and related equipment. SEI hopes that the supply side will join with it in moving forward in this important project. As indicated above, a thermal energy agreement with industry could have a major impact on the supply of thermal equipment and services in Ireland. Potentially, it offers great potential both for an improved business environment and for development of the support relationship between supplier and customer. Ultimately, of course, it offers the possibility of dramatic reductions in energy and energy-related emissions – and a major contribution towards Ireland’s obligations within the Kyoto Protocol. Contact: Chris Hughes, SEI. Tel: 01 - 808 2076



Pilot Technology Agreement with Industry — Energy Efficiency in Boilers and Heat Distribution

Call for Submissions

Sustainable Energy Ireland (SEI) is undertaking a pilot project on negotiated energy agreements with industry, one element of which focuses on energy efficiency in boilers and heat distribution. Within this agreement, the aim is to identify a series of actions which will raise the standards of boiler technology and boilerhouse management to best international standards.

Supplier Participation

The project will include dialogue with suppliers of steam and hot water boilers and related equipment and services, in order to ensure that the most effective and energy efficient technologies and practices are available to participating companies.

Submissions or enquiries should be directed to

Chris Hughes, Sustainable Energy Ireland, Glasnevin, Dublin 9.
Tel: 01 - 808 2076; email: chris.hughes@sei.ie

The closing date for receipt of submissions is Friday, 31 January 2003.

Further general information on the negotiated energy agreements

pilot project is available in the Industry section of our website agreement. Submissions may include views on any aspects of the project, but ideas on the possibilities and considerations for supplier support, and the means whereby SEI should proceed, are especially welcome.

t +353 1 8369080

Glasnevin f +353 1 8372848

Dublin 9 e info@sei.ie

Ireland w www.sei.ie



Sustainable Energy Ireland is funded by the Irish Government under the National Development Plan 2000-2006 with programmes part-financed by the European Union

Mitsubishi Electric G50 Controller — Complex Yet Simple

Mitsubishi Electric's new G50 controller has been developed to offer customers a step into the future of control systems and is claimed to be the first air conditioning controller to use internet technology successfully. By using Internet Explorer as its local or remote software, the G50 gives access to all control functions from the comfort of a personal PC, irrespective of where you are located. Moreover, if the system is malfunctioning, it will

send an alarm to the PC, to a designated mobile phone, and will also send a fax detailing the exact malfunction.

The main features of the system are as follows:

- Internet technology
- Easy to use and operate
- Control multiple sites
- Easy remote access
- Controls up to 50 units
- Easy to upgrade
- Automatic fault alert

The G50 is designed to operate with Mitsubishi Electric City Multi VRF systems and Mr Slim packaged air conditioning systems.

Each G50 controller is capable of controlling up to 50 indoor units on each site. You also have the capability to inter phase 255 G50 controllers. Each controller has its own voltage power supply (PAC-SC50KUA-E).

The G50 has several software upgrades. The upgrades will offer capacity and controllability which ensure the longevity of the G50 and its functions.

These upgrades will include the following

- Energy monitoring
- Demand control
- Year scheduling

Contact: Mike Sheehan, Mitsubishi Electric.
Tel: 01 - 419 8800;
email:michael.sheehan@meeir.mee.com



Sauter "intelligent" HVAC controls from EPH Controls

EPH Controls Ltd in Cork are one of Ireland's foremost instruments and controls specialists, renowned for providing all manner of solutions across a diverse range of industry sectors. Quality of service coupled with quality products is the company's hallmark, its partnership with Sauter as its distributor for Ireland making for a very strong presence in the marketplace.

The Sauter range is all-embracing, new technology being very much in evidence throughout the entire portfolio. A typical example is the new Sauter intelligent valve and damper drives which have set a new industry benchmark thanks to SUT (Sauter Universal Technology). The valve drives are endowed with built-in "intelligence" allowing them to adjust to control requirements automatically. SUT technology is opening up a future of more intelligent regulating units.

SUT valve drives automatically recognise control signals and have

Sauter Intelligent Valves and Damper Drives From EPH

no trouble differentiating between a continuous and 3- or 2- point signal. The drives also automatically adjust to angles of rotation or the valve hub. The operating range and digital feedback signal are also calculated in accordance with recognised limits.

A run-time suited to the application as well as additional parameters can be set directly on the drive or via the integrated bus.

Thanks to SUT, only one type of drive is now needed for all drive methods. This considerably reduces stock and handling requirements.

Installation costs are also minimal. Automatic coupling allows for positive linking between the drive and valve, thus preventing wobbling. The result is a clear improvement in control performance, both for control and diverting valves (VXN/BXN).

Contact: Trevor Casey, EPH Controls.

Tel: 021 - 434 6238;
email:trevorcasey@ephcontrols.com



The new G50 controller from Mitsubishi Electric is claimed to be the first air conditioning control system to successfully use internet technology

NEW

et al.: BS News



Danfoss

MAKING GOOD IDEAS WORK!

Give your customers the power of climate control



TP5000, the programmable room thermostat.

When it comes to matching your customer's way of life to the control of their heating system, the TP5000 programmable thermostat has the power of climate control.

So adaptable that it can be programmed to provide up to six different time and temperature events each day of the week, with different settings for the weekend. So user friendly that it can be programmed almost without instructions. So easy to use that callbacks are a thing of the past.

It is also the ideal controls solution for combi boiler systems.

Good ideas working for you, right around the clock.



TP5000-RF
The radio controlled range



RAS-D
The domestic radiator thermostat



MK18 time controls
The complete time control range

Danfoss Ireland Ltd. Nangor Road Business Park, Dublin 12.

Published by ARROW@TU Dublin, 2002 Tel: 01 6281111 Fax: 01 6269334

email: marketing@danfoss.ie

Home is the Logger, Home From the Sea!

Bob Gilbert of Manotherm is not one given to getting over-excited about product features and benefits. However, even he could not but enthuse about the incredible performance and reliability of Tiny data loggers as demonstrated by the following story. When the managing Director of Guernsey Sea Farms lost a data logger in St Peter Port Harbour, he thought it was gone forever. But incredibly, it turned up over three years later, hundreds of miles away of the Dutch coast. The find was made by a fisherman while trawling for plaice, 50 miles of the coast. He realised the

logger was still active because the green light lit up when he opened the casing. An internet search located the address of Guernsey Sea Farms and the logger was returned. "It arrived back in perfect condition and the data retrieved shows just how robust the loggers are," said Managing Director Mark Dravers. How the logger travelled so far is a mystery. One theory is that after it went missing it travelled with surface currents before finally sinking. Mr Dravers was amazed by its safe return, "The loggers record every half hour for six months and it is a very



useful service. We have never had a failure, although we have lost some. This journey shows just how robust they are," he said. Data loggers are often left in oyster bags to measure temperatures that oysters are exposed to. Temperature monitoring is

very important to oyster farmers, as seawater temperature has a direct affect on the oyster's metabolic rate and the amount of plankton on which it feeds. Contact: Bob Gilbert/Brian Harris, Manotherm. Tel: 01 - 452 2355; email: manotherm@eircom.net

Customised Multi-Tube Flow System

The new Dwyer Series MTF Multi-Flow Tube System from Manotherm is customised to fit any flow application requirements for either 65mm or 150mm variable area flow tubes. The Series MTF offers the convenience and simplicity of 2, 3, 4, 5 and 6 tube meters while retaining the design features associated with single tube variable units. It is ideal for applications where several streams of gases or liquids are to be metered in individual channels or manifolded. Some design features of the Series MTF are:— interchangeable flow tubes and floats; manifolding at the inlet

or outlet; chemical compatibility; easy installation; and fluted metering tubes to provide accurate and stable reading. The Series MTF flow system has an accuracy of $\pm 2\%$ FS at 70°F (21°C) and 14.7psia (1 atm absolute), and a repeatability of ± 0.25 of scale reading. The maximum operating pressure is 200 psig (13.8 bar) and the maximum operating temperature is 250°F (121°C). Depending on the application, the user can choose from 316 stainless steel, glass, or sapphire floats, and either Buna-N or Vitone of-rings. The MTF is built to the

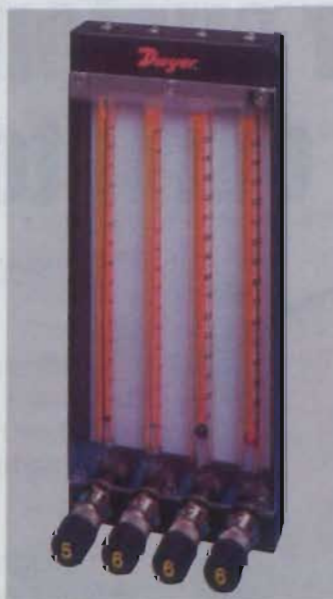

The new Dwyer Series MTF Multi-Flow Tube System from Manotherm users' specifications. Contact: Bob Gilbert/Brian Harris, Manotherm. Tel: 01 - 452 2355; email: manotherm@eircom.net

News Flash From Flash!

As we went to press Tom Noone of Chronotherm Controls told *BSNews* that an innovative mechanical central heating timer incorporating 1-hour boost from Flash will be made available early in the new year. Full details in our next issue.

Contact: Tom Noone, Chronotherm Controls. Tel: 01 - 864 3793; Fax: 01 - 834 2912; Mobile: 087 - 255 3703

SIEMENS

Landis & Staefa Division

The best choice of valves and actuators for heating, ventilation and air conditioning of small to medium sized plants:



Complete offering

Broad range of actuators and valves for small to medium-sized plants. Ease of mounting, commissioning and service in rooms, zones and plants.

Innovative design

Compact design of valves and actuators with a choice of interfaces for all electrical standard signals. The innovative fail safe facility is electronic

Your benefits

A modular and affordable priced concept. Can be integrated into any system. Ease of installation and service.

- Simple direct actuator mounting
- Valves rated at PN16
- Sizes up to DN40
- Suitable all standard electrical signals
- Fail safe facility
- Proven assembly of actuator & valve

*These and other Landis & Staefa products are available from **FläktWoods***

FläktWoods

Fläkt Woods (Ireland) Ltd
ABB House, Belgard Road
Tallaght, Dublin 24

Tel +353 (0) 1 463 4600

Fax +353 (0) 1 463 4650

www.flaktwoods.com

Published by ARROW@TU Dublin, 2002

Siemens Building Technologies
Landis & Staefa Division
Hawthorne Road,
Staines,
Middx
TW18 3AY

Tel +44 (0) 1784 461616,

Fax +44 (0) 1784 464646,

www.landisstaefa.co.uk

Fläkt Woods and Siemens Controlling Your Environment

Continuing the last 30 years of its successful business partnership with Siemens, Fläkt Woods is one of the main agents for the range of Siemens Landis & Staefa industrial and residential controls.

Fläkt Woods and Siemens offer reliable solutions for all building and control requirements. Based at its office in Belgard Road, Tallaght, Dublin 24, Fläkt Woods stocks a comprehensive selection of industrial and residential controls.

valves, actuators, sensors and controllers, all of which are available from Fläkt Woods. The range of open air damper actuators have an extremely compact design and come with excellent torque/size ratio.

Open air damper actuators are designed for fast installation resulting in lower installed cost. Additional features include magnetic clutch, built-in disengagement button, and cats eyes position indicators.



Siemens damper actuator from Fläkt Woods

The Siemens brand has a long tradition of reliability and excellent product performance, and is a market leader in controls for the heating, ventilation and air conditioning industry. Included in the range of industrial controls are

Fläkt Woods Residential Controls Section offers great product variation and choice. With its large wholesaler and heating and plumbing base nationwide, the company provides a large selection of residential controls to suit almost all

applications. The range includes timeswitches, thermostats, programmers, zone valves, radiator valves and heating controls. Fläkt Woods has also recently added the Siemens range of electric and storage heating to its portfolio.

Contact: Siemens Industrial Controls – David McMenemy; Siemens Residential Controls – Michael

Murphy.
Tel: 01 - 463 4600;
Fax: -01- 463 4650;
Web:
www.flaktwoods.com



Siemens residential controls from Fläkt Woods

Simple Push-Fit From Sunvic

Chronotherm Controls Ltd have an extensive portfolio from leading brand names to cater for all applications. The Sunvic range is a typical case in point, its range of cutting-edge products incorporating innovative technology including digital timers, 1- and 2-channel timers; room thermostats; frost thermostats; immersion thermostats, including new safety stats with high limit (to comply with new Standard for 2003); and motorised controls.

One of the latest additions to the motorised controls range is the revolutionary "push-fit" motor which is fully compatible with all spring-return applications; has identical wiring; click-on actuator; wheel for manual open/close; requires no screws to fit; covers all sizes — 1/2", 3/4", 1" BSP and 15mm, 22mm 28mm compression.

Contact: Tom Noone, Chronotherm Controls.
Tel: 01 - 864 3793; Fax: 01 - 834 2912; Mobile: 087 - 255 3703.



The new Sunvic push-fit motor from Chronotherm

Can You Afford Not to Use an Electronic Flue Gas Analyser?



If you mainly service oil or larger gas boilers, a full flue gas analyser such as the popular Kane 400 is recommended.

Over the years many gas and oil boiler service engineers have been reluctant to buy an electronic flue gas analyser due to the cost. Other engineers may have been put off because they thought that analysers were difficult to use. Thankfully, we rarely hear these complaints today! For example, a performance analyser such as the Kane 300 for domestic gas boilers is now available for less than €400 compared to €600 for the equivalent model three years ago. Running costs are also low, the cost of having a Kane 300 checked and recalibrated once a year and fully

serviced every other year is equivalent to approximately €3 a week. Modern analysers are also quick and easy to use, they self-calibrate in 20 to 30 seconds and have large easy-to-read displays. A combustion test on a warm boiler can be completed in less than five minutes, including a printout of the results. Combustion fact sheets are also available to help engineers understand the results. The basic tests on a gas fired appliance are to use a smoke match to check flue draught and a "U" gauge to check fuel supply pressure. While these techniques work, an electronic test and a

printout give the customer added confidence and the engineer a more professional image. All major boiler manufacturers now issue electronic analysers to their service engineers.

Customers are now much more aware of the dangers of carbon monoxide (CO) poisoning. Traditionally CO was measured using a chemical test that was both slow and expensive.

Electronic flue gas analysers that conform to the UK standard, BS7927, will read to 1ppm resolution and can be used to accurately measure ambient CO around an appliance, as well as CO levels in the flue.

In the UK a "Code of Practice", BS 7967, is due to be issued shortly. This covers the use of electronic analysers to measure CO and CO₂ and will reinforce the fact that, used correctly, electronic analysers ensure that domestic appliances operate safely and efficiently. It states that the analyser must conform to BS7927.

If you only install new appliances, a CO analyser is the minimum recommended because it will tell you whether CO is present in a room and locate where it is coming from. An instrument with an integral pump and a sampling probe with hose will also enable you to check CO levels in the flue. Anyone servicing and repairing domestic gas appliances should be using a performance analyser such as the Kane 300. In addition to measuring CO, it calculates the CO/CO₂

ratio. This information can help you decide if an appliance needs dismantling and cleaning, saving you time and reducing service errors. Make sure you record your tests, either via the analyser's optional printer or in its memory for later transfer to a printer. The service company's name and telephone number at the top of the printout adds the finishing touch. If you mainly service oil or larger gas boilers, a full flue gas analyser such as the popular Kane 400 is recommended. The Kane 400 is still suitable for domestic gas appliances but also measures flue and inlet temperature, calculates combustion efficiency and measures differential temperatures and differential pressure. Other models such as the KM900 can also measure NO_x and download to a PC.

Advice on selecting the best analyser for your type of work and copies of the combustion fact sheets are available via branches of Heatmerchants/Gas & Oil Parts.

Contact: Frank Gilsean, Heatmerchants/Gas & Oil Parts.

Tel: 01 - 454 1900.



Models such as the KM900 can also measure NO_x and download to a PC

Danfoss Programmable & Set-Back Thermostats

Danfoss Randall has introduced a new range of programmable room thermostats and set-back thermostats, bringing a new and modern style to the market. The programmable thermostat, type TP5000, will in time replace the TP5E model, while the RT51 and RT52 set-back models will replace the

models. The TP5000 combines the functionality of a room thermostat and timeswitch into a single, simple-to-use controller. Offering 5/2-day operation, up to six time and temperature changes per day, with a different programme for weekends, the TP5000 is an ideal solution for

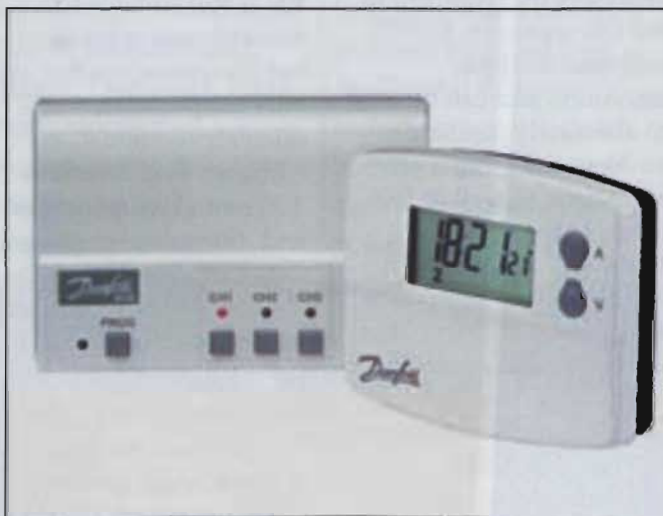

Danfoss Randall TP5000 controller and RX-3 receiver unit from Danfoss Ireland

RT1 and RT2 respectively. All of the models in the range come in a stylish, ultra-slim enclosure with a large easy-to-read LCD display. Programming follows the well tried and tested method used for many years in the TP series, recognised by all for its simplicity and intuitiveness. All models are battery powered and incorporate a wallplate for ease of installation. Wireless models offer identical functionality to that of the hard-wired

combi-boiler systems. In addition to programmed temperatures, the thermostat can also be programmed to turn the heating off at user-defined times. Other useful overrides include temporary temperature overrides, thermostat mode, and a weekend into weekday override which is ideal for holiday periods. If required, the TP5000 can also be set up to provide just two events each day, making it an

ideal solution for commercial applications. The RT51 and RT52 provide two temperature settings — one typically used in the day and another for the night periods of inoccupancy. The RE51 offers manual return to day setting, while the RT52 incorporates a timer which automatically returns the thermostat to day temperature operation at a user-defined time which is repeated every day. The RF version of all three thermostats are ideal for use in situations where a quick and easy installation is required. Wiring is limited to that needed between the RX receiver unit and the boiler or valve it is controlling. No wiring is needed between the thermostat and the boiler, making all three thermostats ideal for both new and upgrade situations.

All RF versions are equipped with a radio transmitter which utilises secure digital FM communication between the thermostat and a receiver unit, which can be mounted up to 30 metres away. Contact: Brian Maguire, Sales Manager, Danfoss Ireland. Tel: 01 - 626 8111; email: marketing@danfoss.ie

The cover of the 'Building Services Buyer Guide 2003/2004'. It features a photograph of a white Vent-Axia air conditioning unit mounted on a wall. The text on the cover includes 'Building Services Buyer Guide 2003/2004', 'The Definitive Guide to the Building Services Industry', 'Price €30', and a large '5 YEAR GUARANTEE' badge. The Vent-Axia logo is in the bottom right corner.

Need extra
copies
of the
Buyer Guide
2003/4?

Call Louise at
01 - 288 5001

Individual
Copies — €90

Discount for
Multiple
Orders

Ultimate Solution From Siemens Building Technologies

With the acquisition of Preussag Champion Fire Defence, Siemens Building Technologies are now the market leader in fire safety systems in Ireland.

To further leverage this position of strength, the Fire Safety and Building Automation (Sirus Engineering Systems) divisions of Siemens Building Technologies are now working together to offer the ultimate solution for fire safety, security, access control and HVAC BMS applications.

Buildings differ not only in size and the way they are used, but also in their requirements for comfort, safety, security and climatic conditions.

Any building must provide the sort of working environment that will ensure maximum benefit in terms of efficiency and return on investment, while also guaranteeing the safety and security of the occupants.

An integrated management system enables a building to be operated more easily and with greater efficiency, so helping to reduce operating costs and increase profitability. Instead of using a variety of devices for operation, the operator can

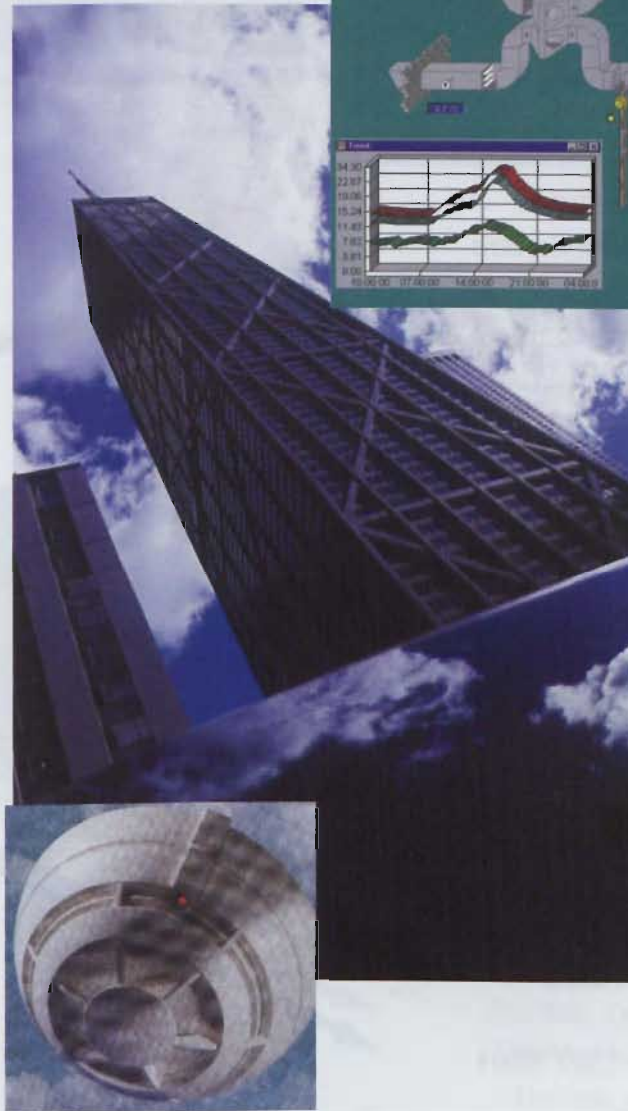

perform all activities from a single management station, keeping training costs to a minimum and reducing the likelihood of incorrect operation.

Further, if all the systems in the building are brought together in a single management station, faults and alarms can be identified

and dealt with immediately for the better protection of people and property.

These factors must be taken into account when selecting the equipment and companies to design, install and commission the building systems.

When it comes to fire safety, security, access

control and HVAC BMS systems, Siemens Building Technologies are an ideal partner no matter what type of building or what type of process will take place. As one of the world leaders in this field, it has acquired extensive experience and know-how over many years. This enables it to provide high quality solutions at a competitive price.

By fully understanding the requirements, Siemens Building Technologies can create added value and first class benefits for customers through leading-edge technology and superior applications.

Contact: Siemens Building Technologies Fire Safety —
Tel: 01-450 8920;
Building Automation —
Sirus Engineering Systems.
Tel: 01-460 2600



ES-PIR — Passive Infra-red Sensor

Twin Fans (include)

- Auto changeover and duty share
- Run-on timer
- Only one power supply cable



ES-CO2 — CO₂ Sensor

Low Noise Levels

- Tested to BS848 Part 2
- AMCA 300
- Performance tested to ISO 5801

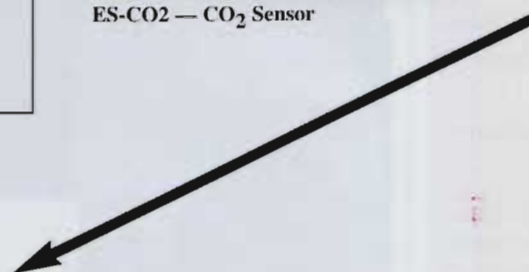

ES-TEMP — Temperature Sensor

Remote Enab
 B.M
 Time
 P.I
 Commis

SPEED C
 FAN FAI

ecos

B.M.S. IN
 REMOTE
 S.E.L.V.

Remote Speed C
 C
 Tempe
 Relative
 Manual Us
 B.M

These controls ha
 A separate remote a
 is also a

RED

Unit 4, 70 Heather Road, Sandyford
 Tel: 01 - 294 0321/3/4; Fax: 301 - 2

aire

ing Devices
I.S.
clock
R.

ssioning

ONTROL
L LED'S

mart

ERFACE
SENSORS
CABLE

Control Sensors

O₂
erature
Humidity
ser Control
I.S.

ve fail indication.
udio visual indicator
available.

BRO

Industrial Estate, Foxrock, Dublin 18.

94 03251 email: ARROW@td.dublin, 2002



ES-UCF — Manual User Control (Fan Only)
ES-UCFH — Manual User Control (Fan and Heater)



Belt Drive & Direct Drive

Roof — curb and inline
Indoor and Outdoor
Cased, Circular and Square



ES-RH — Relative Humidity Sensor



Centrifugal, Mixed Flow & Axial

Input power up to 13kW
5m³sec v 1000 Pa Circular Fans
7m³sec v 1200 Pa Square Fans
4m³sec v 1000 Pa Twin Fans



ES-TC — Time Clock



VEHA Launch Design & Towel Radiators

Designer radiators offer greater choice to the homeowner or builder as well as a great profit opportunity for the installer. Stylish towel radiators are what every bathroom deserves and every housewife puts on her "must have" list.

Veha, with the introduction of their new Design and Towel Radiator ranges, has brought both products into play for every installation. Firstly, because they are realistically priced and secondly because they are easily available from Veha stockists.

Design radiators have been individually styled by some of Europe's leading industrial designers. Four models make up the range. Opus comes in flat profile or tubular, both in a vertical

2-metre high format and three lengths so it can be fitted into narrow reveals for example, while making a style statement in the room. Adagio has a distinctive flat waterway profile and comes in a unique silver black finish. The Primo models are flat finished with a subtle rounding at the edges, finished in white, and offering a wide choice of 20 sizes and outputs. Forza is a new approach to column radiators, useful perhaps in refurbishment projects in older homes. The white finished column models come in 22 sizes across two, three and four column widths.

The Towel Radiator range offers six models, in curved, straight and framed rail styles. Quality of finish is a key feature.

The chrome finished Sapphire and Diamond models use the highest Grade 1 quality of chromium plate for an exceptionally bright finish that will last and last. The Emerald and Jade models, Opal and Pearl with contemporary tubular look, are all finished in high quality sparkling white to complement any bathroom or shower room wall. Outputs are easy to choose, with 35 height and width options.

Oliver Hynes of Veha emphasised the opportunities the new ranges offer the installer. "With sensible prices and delivery from their stockist, the new Veha Design and Towel Radiator ranges mean that the new rads can be offered as part of any project. Result? Happy customers and a better, more profitable installation."

Brochures and stockist information from Veha. Tel: 0404 - 67278.



Forza from Veha is a new approach to column radiators
<https://arrow.tudublin.ie/bsn/vol41/iss10/1>

Need extra copies of the Buyer Guide 2003/4?



Call Louise at 01 - 288 5001

Individual Copies — €90

Discount for Multiple Orders

S T E L R A D et al.: BS News

Compact with
Style

ITS LOOKS ARE STUNNING AND OUT OF ALL PROPORTION TO ITS PRICE

THE NEW STELRAD COMPACT RADIATOR WITH STYLE BRIDGES THE GAP BETWEEN STANDARD RADIATORS AND THE MORE EXPENSIVE DESIGNER MODELS.

IF YOU ARE WORKING TO A TIGHT BUDGET BUT REQUIRE A RADIATOR THAT IS DIFFERENT, THEN YOU HAVE FOUND IT WITH THE STELRAD COMPACT WITH STYLE.

STUNNING GOOD LOOKS ARE COMBINED WITH THE QUALITY AND PERFORMANCE YOU WOULD EXPECT FROM STELRAD, THE UK'S No.1 RADIATOR MANUFACTURER.

- 44 STANDARD MODELS, heights of 300, 500, & 600mm, widths from 400mm to 2000mm. Btus/Watts on K1 from 970/284 to 7293/2137 and on K2 from 1880/551 to 12945/3794.
- 8 LO-LINE MODELS, 200mm in height with widths of 500, 1000, 1400 and 2000mm. On P+ models Btus/Watts from 983/288 to 3934/1153, and on K2 models, Btus/Watts from 1231/361 to 4926/1444.
- 12 VERTICAL MODELS, heights from 1600 to 2400mm, and widths of 300, 500 and 600mm. Btus/Watts from 3043/892 to 7638/2239.



For a full detailed brochure, or more information simply contact us or visit our website: www.davies.ie
Tel: 01 837 6076
Fax: 01 837 2863
Email: info@davies.ie

 **Stelrad**
THE RIGHT CHOICE

Published by ARROW@TU Dublin, 2002

DAVIES
PLUMBING HEATING
BUILDERS PROVIDERS
Est. 1933

Myson Radiators — 'The Choice for the Future'



From the Myson Select radiator range by Potterton Myson

Myson is one of Europe's leading manufacturers of radiators. For both domestic and commercial use, the Myson range offers a wide choice of models, outputs and sizes. This offers the installer or specifier complete flexibility and the knowledge that there is a Myson radiator to suit almost every possible situation. In addition, all Myson radiators carry at least a 5-year guarantee. The Myson radiator range consists of the Premier, Select, Chorus, LST and Eclipse radiators.

Premier — The Myson Premier HE range comprises elegant, stylish and highly-efficient radiators. With the unique high-efficiency convector plate, Myson has created a radiator that is more compact and less obtrusive than others while also

increasing its efficiency and output.

Only fully-finished steel is used in the production of the Premier HE range and this, coupled with advanced welding techniques, ensures the highest quality and durability.

Select — The Select is a seamtop radiator available as a standard, single and double convector, or complete with factory-fitted grilles and end-panels. The innovative design ensures that quality and outputs are of the highest order and these are approved to stringent European test procedures.

Chorus — Chorus radiators are elegantly and distinctively designed with a particular focus on aesthetics and performance. The Chorus range consists of four product types — the Vertical, Horizontal, the

Column and the Plinth.

As well as offering a stock range, Chorus radiators can be custom made, offering a wide choice of dimensions and colours.

LST (Low Surface Temperature) — The low surface temperature of Myson LST radiators makes them ideal in situations where safety is paramount. Increasingly, they are specified and installed by health authorities, local authorities, government departments, leisure centres and public buildings. LST radiators come in a range of 62 sizes and outputs ranging from 325 watts to 3746 watts.

Eclipse — Myson Eclipse radiators are intended for use where architects or specifiers demand a flat unobtrusive front surface combined with great strength and durability. Typical applications include banks, offices, hotels and public buildings

Myson Towel Warmers — Elegant and stylish, Myson Towel Warmers are assembled by craftsmen using only the finest quality materials. In addition to enhancing the appearance of a bathroom, they are both economical and efficient to run.

There is a wide range of standard units of different designs to choose from, or one can be manufactured to personal requirements. These modifications include size, shape, colour, changes to tapping size and position, dezinc-proof units and copper panel radiators.

Stringent quality control ensures that the highest standards are maintained with every towel warmer pressure tested before

leaving the factory.

Models available include floor standing and wall mounted versions; multi-rail; brass, chrome or paint finishes; radiator towel warmers and electric towel warmers. There is also a full range of complementary accessories including valves, sleeving kits and wall stays.

Myson Fan Convectors — Myson's convector heaters open up whole new perspectives for heating and home improvement. Designed to fit into small "dead" spaces under units of the floor, the Kickspace costs less to run than a 40 watt light bulb.

There is a comprehensive Kickspace range available, in addition to wall-mounted, slimline and hi-level units.

Column — The Myson Column range is manufactured from the highest quality steel but caters for the retro market with its cast-iron look. Ideally suited for commercial or upmarket residential applications, it is available in a variety of sizes and styles, including the attractive Bench radiator with its beech-laminated seat incorporated into the radiator.

Myson Underfloor — Adaptable to all types of floor construction, the Myson underfloor range is suitable for most floor finishes, including ceramic tiles, timber and carpet. Complete controls systems means the range can be incorporated in all new modern commercial and domestic design applications.

Contact: Sales Office, Potterton Myson (Irl).
Tel: 01 - 459 0870;
Fax: 01 - 459 0880.

THE ONLY NAME FOR RADIATORS **concept** *Plus*

- Tastefully designed with in-built quality and heat efficiency.
- All **CONCEPT PLUS** Radiators come complete with wall brackets and all necessary screws and connections.
- Free top and side panels with all Type 11k, 21k and 22k radiators.
- All heat outputs are in accordance with and conform to DIN, NF, UNI, ISO, BS 3528 and EN 442 standards.



● *Unique Seven Year - "No Quibble - No Fuss" Manufacturers Guarantee*

HEATED TOWEL WARMERS

MEGA STRAIGHT

The Mega Straight from Sile is available in both a white and a move finish and is an essential component of any bathroom

It is practical to install, easy to clean and available in a wide range of convenient sizes.

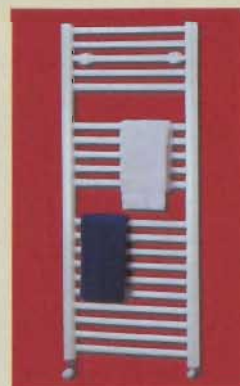

We've everything for your Heating & Plumbing needs !!

- RADIATORS
- GAS & OIL BOILERS
- COPPER PIPE & FITTINGS
- PVC PIPE & FITTINGS
- HEATING SPARES
- BATHROOM SUITES
- SHOWER VALVES
- SHOWER DOORS

Branches Nationwide
www.heatmerchants.ie



Incorporating

heatmerchants
Gas & Oil Parts

ARKLOW GALWAY ATHLONE KILKENNY BRAY LETTERKENNY CASTLEBAR LIMERICK CAVAN MALLOW CLONMEL NAAS CORK (3) NAVAN DUBLIN (4) PORTLAOISE DUNDALK SLIGO DUNGARVAN TRALEE ENNIS WATERFORD

HEATmaster — The Hot Line in Radiators

Heatmaster Radiators — a trading division of the Cork-based Maple Marketing Ltd — continues to increase its share of the Irish domestic heating market since its launch in mid 1999.

Maple Marketing Ltd was established in 1985 and is the exclusive distributor in Ireland for "HEATmaster" radiators and towel rails. Just recently it expanded its product portfolio in this sector with the addition of two new products — Murrano bathroom accessories from Italy featuring coloured glass in a classic Italian design; and Rodolfo Navarro bathroom mirrors with a distinctive Spanish flare.

Since the launch of the HEATmaster in mid-1999, this product quickly

succeeded in establishing a reputation for quality and service to a national network of builders providers and heating and plumbing merchants.

Designed for economical performance, style and efficiency, HEATmaster radiators are manufactured to the ISO9001 Quality System and are certified to DIN EN442. The final finishing process is in compliance with DIN 55900. The process involves totally submerging all radiators in a primer paint which is oven-baked and finally coated by a series of multi-spray applications of RAL 9010 white epoxy-polyester electrostatic powder paint cured at 200°C.

Product Range & Type

— The HEATmaster

compact convector range includes factory-fitted top and side covers, at no extra cost, on both the single and double convector types. Chrome air vents, plugs, sealing rings, wall brackets, nylon buffers, screw and wall plugs are all included within the packaging of the radiator.

The range is produced in heights of 300mm, 400mm, 500mm, 600mm and 900mm, and in lengths from 400mm to 3000mm. Top and bottom opposite end 1/2" connectors are standard.

Packaging — The high quality, aesthetically-pleasing HEATmaster product is carefully packed and protected by the use of carton box end-sleeves; plastic protectors fitted to wall plugs; bubble-wrapped; and

finally double shrink-wrapped in a heavy gauge polythene protective film. The HEATmaster radiator is therefore fully-protected from factory despatch to final installation.

HEATmaster Towel Rail — This product is manufactured to the same exacting standards as the convector radiators, and also produced in the matching colour RAL 9010 white. The stylish and functional design enhances the utilisation of restricted spaces in bathrooms and kitchens, providing heat while holding and drying towels.

Customer Care & Service — Maple Marketing's nationwide delivery service (in partnership with its logistics operators) ensures that delivery will be made anywhere within 48 hours from receipt of order.

The HEATmaster ranges carry a 5-year, no-quibble guarantee against any defects caused by faulty materials or manufacture. Experienced and friendly staff are readily available to assist and advise customers with technical and promotional back-up.

Contact: Charles Wheeler or Aidan Martin, Maple Marketing.
Tel: 021 - 496 8388;
Fax: 021 - 496 8454;
email: maple@indigo.ie



The HEATmaster portfolio includes radiators and towel rails

BTUtiful



For style and elegance with BTUtiful traditional design and craftsmanship of yesteryear, the Chappee cast iron "Floreal" is the ideal radiator choice for a "classy" finishing touch in period buildings, or a spectacular contrast in contemporary settings. The "Floreal" is supplied in "old grey" natural shade but of course can be painted in any colour of your choice to enhance/complement your particular setting.

Despite its traditional origins, the "Floreal" is a very efficient and effective heating medium and is available in a range of sizes.

To see the full range of BTUtiful cast iron radiators, drop in to the Hevac showroom today.



Hevac Limited

Danfoss Push-Fit Eases the Strain

Danfoss has introduced a versatile new push-fit version of its popular RAS-C and RAS-D TRVs. Available in combi packs, complete with all of their normal features, these new TRVs have an elbow that incorporates a push-fit pipe fitting that can be used on copper and most leading brands of plastic pipe.

It has been designed to offer the heating installer and house builder the fastest and best solution when fitting radiator thermostats into central heating systems where either plastic or copper pipes have been specified.

Currently around 20% of all new domestic systems make use of plastic piping and the sale of plastic pipes is currently growing by 20% per year. Push-fit and plastic pipes could easily become the favourite choice in Ireland within the next five years.

More and more installers and builders have already discovered the benefit of push-fit fittings and the use of plastic pipes due to:

- A general demand for increased productivity and reduction of defects in the construction industry's
- A continuous need for a reduction in construction time to reduce build times and improve cash flow;
- A general demand to reduce installation times and complexity due to the shortage of skilled labour.

By using the Danfoss TRV with push-fit elbow, the installer is able to optimise the speed of installation and achieve full flexibility in terms of workflow and neatness of

installation. The push-fit elbow offers a neat installation in situations where pipes are installed into dry lining, by allowing plastic piping to be used throughout the whole heating installation. The push-fit elbow is suitable for use with copper pipe and most popular plastic pipes, including Hep20, Polyplumb, OsmaGold, Speedfit and Equator (NB: Plastic pipes, must comply with BS7291). It is important when using plastic pipes that a pipe insert of the same brand as the pipe is used.

All push-fit fittings can be further secured with a clip or an attractive white cover cap to complete the installation. If, for some reason, it becomes necessary to remove the pipe, this can be done in one quick operation, without causing any damage to the pipe or fitting.

Contact: Robert Fitzpatrick or David Holmes, Danfoss Ireland Ltd.
Tel: 01-626 8111;
email:marketing@danfoss.ie



Danfoss Push-Fit eases the strain



New Barlo Design & Towel Radiators

Designer radiators offer greater choice to the homeowner or builder as well as a great profit opportunity for the installer. Stylish towel radiators are what every bathroom deserves and every housewife puts on her "must have" list. Barlo, with the introduction of their new Design & Towel Radiator ranges, has brought both products into play for every installation. Firstly, because they are realistically priced, and secondly because they are easily available from Barlo stockists.

Design radiators have been individually styled by some of Europe's leading industrial designers. Four models make up the range. Opus comes in flat profile or tubular, both in a vertical 2-metre high format and three lengths so it can be fitted into narrow reveals for example, while making a style statement in the room. Adagio has a distinctive flat waterway profile and comes in a unique silver black finish.

The Primo models are flat finished with a subtle rounding at the edges, finished in white, and offering a wide choice of 20 sizes and outputs. Forza is a new approach to column radiators, useful perhaps in refurbishment projects in older homes. The white finished column models come in 22 sizes across 2-, 3- and 4-column widths.

The Towel Radiator range offers six models, in curved, straight and framed rail styles. Quality of finish is a key feature. The chrome finished Sapphire and Diamond models use the highest, Grade 1 quality of chromium plate for an exceptionally bright finish that will last and last. The Emerald and Jade models, Opal and Pearl with contemporary tubular look, are all finished in high-quality sparkling white to complement any bathroom or shower room wall. Outputs are easy to choose, with 35 height and width options.

Oliver Hynes of Barlo emphasised the opportunities the new ranges offer the installer: "With sensible prices and delivery from their stockist, the new Barlo Design and Towel Radiator ranges mean that the new rads can be offered as part of any installation. Result? Happy customers and a better, more profitable installation."

Brochures and stockist information from Barlo.
Tel: 052 - 27377.

- Offer the widest range of heating products in Europe
- Myson provide outstanding customer service at all levels
- All Myson products are manufactured and tested to BS EN 442
- All Myson products are available across Ireland through all major merchants

Myson Radiators

innovative heating solutions

MYSON
Radiators

Potterton Myson (Ireland) Ltd
Belgard Road, Tallaght, Dublin 24
Tel: 01 - 459 0870
Fax: 01 - 459 0880
email: post@potterton-myson.ie



Column



LST



Underfloor



Select



Premier HE



Eclipse



Fan Convectors



Kickspace



Chorus

HEATMASTER CONVECTOR RADIATORS

THE HOT LINE IN RADIATORS

Manufacturing — Heatmaster

Radiators are produced from 1.25mm gauge cold rolled steel employing advanced press tool technology in state of the art presses.

Radiators are produced in lengths from 400mm to 3000mm and in heights of 300mm, 400mm, 500mm, 600mm and 900mm. Finished in RAL9010 white electrostatic powder paint.



5 ★ ★ ★ ★ ★
YEAR Warranty



maple
marketing

SOLE DISTRIBUTORS IN IRELAND

Maple Marketing Ltd, Ballycurreen Industrial Estate,
Airport Road, Cork.

Tel: 021 - 496 8388; Fax: 021 - 496 8454; email: maple@indigo.ie

Innovative Myson Heating Controls

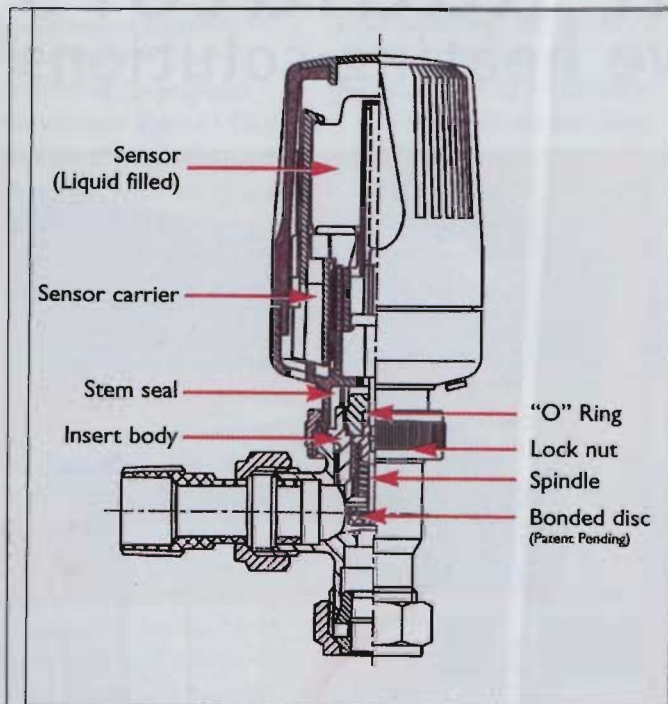

Myson Heating's TRV 2-way radiator valve specification

In recent years Myson Heating Controls has carried out a large capital investment programme at its Newcastlewest, Co Limerick manufacturing plant. Today, the production facilities are the most advanced in the industry, state-of-the-art equipment such as the new stamping press making for quality performance to the most exacting standards.

The same emphasis is placed on R&D and new product development. Myson Heating Controls has designed a comprehensive range of controls which guarantees complete control of home heating. Manufacturing of the highest standards have allowed the company to produce a top-quality product that's kinder to the environment

and reduces energy consumption. The range includes the following:—

Temperature Control TRV-2-Way — The Myson TRV 2-Way is a highly-innovative product which is fully designed and engineered by Myson Heating Controls in Newcastle West, Co Limerick. Complete with the benefits of the well-established TRVII, such as the temperature-sensitive liquid element and the sculpted white wheelhead, it is available in a range of sizes. It also comes in a wide choice of finishes, including polished chrome, satin brass and nickel.

In standard TRVs many components comprise the internal spindle and disc assembly. However, in the TRV-2-Way, Myson uses a new bonding technique

(patent pending), which prevents the flexing of this internal disc when water flows in the "wrong" direction. What results is the elimination of those all-too-familiar rattles and bangs.

To complement the standard 15mm Myson TRV2-Way, an extensive range of accessories is also available, including remote adjusters, remote sensors and theft controls.

Thermostatic Cylinder Valve (TCV) — Designed for use in domestic central heating systems, the new Thermostatic Cylinder Valve provides non-electric control of the domestic hot water temperature by limiting the primary flow or return.

Manufactured by Myson Heating Controls in Limerick, the TCV is both easy to install and simple to operate.

Flow Control (Power Extra Motorised Valves MPE) — The Myson Heating Controls MSV Range of System Control Valves was recently rebranded as Myson's Power Extra Motorised Valves (MPE). This range of system control valves has been designed for use in fully-pumped combined central heating and hot water systems.

The MPE 222 and MPE 228 2-port valves will control the central heating or hot water circuit. Used

in combination, these two valves will satisfy the requirements of most fully-controlled systems. If necessary, additional MPE 2-port valves can be used to split the central heating system into several circuits to provide greater control.

The MPE 322 and 328 3-port mid-position valves which can boast a market-leading 6-Watt Class 'F' Motor, will control both the central heating and hot water circuits simultaneously. These valves may be operated directly by the system programmer, or indirectly, by room and cylinder thermostats.

To complement the existing 22mm 3-port valve, Myson Heating Controls has introduced a 28mm 3-port valve.

Automatic Bypass Valve (ABV) — The Automatic By-Pass Valve is a system relief valve which can be used to balance the heating system.

Combined with the thermostatic radiator and motorised valves, it allows the system pressure to be relieved when all other components are closed down.

Contact: Sean Hanratty, Myson Heating Controls.
Tel: 069 - 62277;
Fax: 069 - 62448;
email: enquiries@myson.ie
Web: www.myson.ie



Towel Design Radiators

High quality, High Design, Low cost



Pearl



Diamond



Sapphire

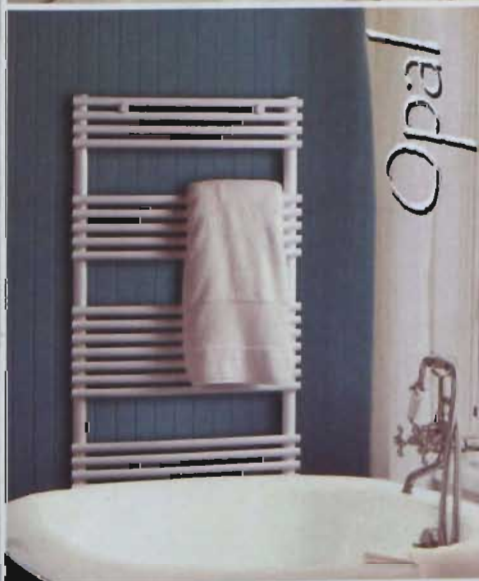

Opal



Emerald



Jade

Chappee Elegance by Hevac

When it comes to enhancing any location Chappee cast-iron column radiators are the perfect heat emitter. Its wide range of radiators offers a variety of styles and elegance unrivalled by any other manufacturer.

For period properties and traditional furnishing styles, the "Floreal" cast-iron radiator, with its delicate classic inlaid scrolled detail, offers traditional craftsmanship to complement and provide the perfect finishing touches to any building. The Floreal is the perfect radiator for that period building, restaurants, hospitality suites, hotels, receptions, public houses, conference facilities etc.

It is perfect either for new heating systems or for replacing outdated or antique radiators with the minimum disruption to existing

installations. The free-standing "Floreal" will avoid damage to walls, with its 750mm height it is ideal to fit neatly below standard dado rails. Supplied in an attractive gun-metal primer finish which will complement most colour schemes, although if required the "Floreal" can also be painted to match any decor requirement.

Assembled radiators are available from Hevac's stores in Dublin and can be delivered to site in lengths comprising from three to 21 sections. Further sections may be assembled on site for longer finished radiators.

With classic simplicity of design the "Dune" radiator from Chappee captures all the elegance and traditional quality of a bygone age. With similar dimensions and section widths to

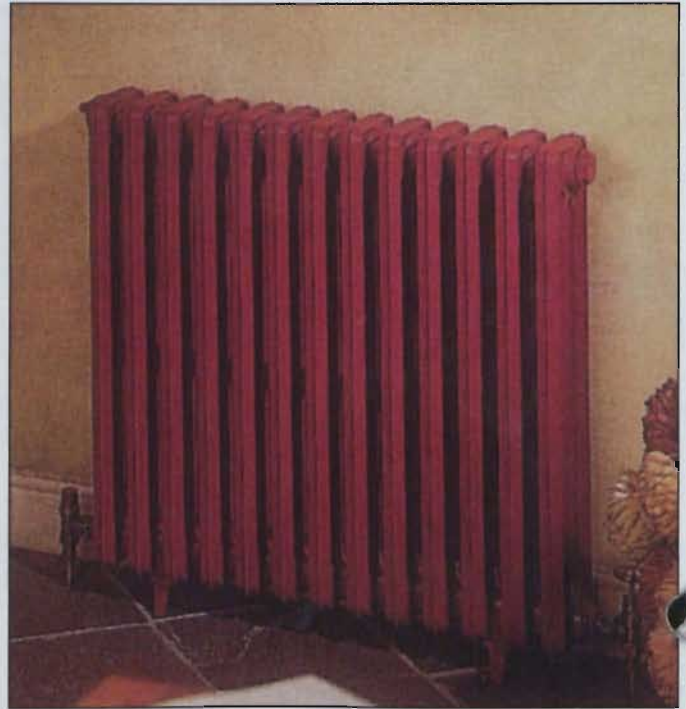

From the Chappee range of cast-iron radiators contact Hevac

Assembled radiators are available from Hevac's stores in Dublin and can be delivered to site in lengths comprising from three to 21 sections. Further sections may be assembled on site for longer finished radiators

traditional and obsolete column radiators, the "Dune" provides the perfect replacement with the minimum disruption to existing installations.

Ideal for modern or traditional settings alike, the "Dune" is supplied from Hevac's Dublin store in a primer finish and can be delivered to site assembled or, where necessary, assembled on site.

To complement and

complete the package Hevac offers a range of brass radiator valves which include the much-favoured, traditionally-styled solid brass Floreal Radiator valve available from Hevac in 1/2" and 3/4".

Detailed literature is available on request from Hevac Ltd.

Tel: 01 - 419 1919;
Fax: 01 - 458 4806;
email: karlc@hevac.ie

Cork

Tel: 021 - 432 1066;
Fax: 021 - 432 1068.

THE 2-WAY

THE NEW MYSON TRV 2-WAY IS SET TO MAKE YOUR LIFE SO MUCH EASIER, SINCE THERE'S NO NEED TO CHECK THE DIRECTION OF THE WATER FLOW.

THAT'S

COSTLY CALL-BACKS DUE TO "SNAGGING" WON'T BE PUTTING PRESSURE ON YOUR TIME OR YOUR BUSINESS. BUT HERE'S WHY THE COMPETITION IS REALLY RATTLED.

GOT THE

ONLY THE NEW MYSON TRV 2-WAY'S UNIQUE ENGINEERING ALLOWS THE VALVE TO OPERATE CORRECTLY AT ALL DIFFERENTIAL PRESSURES, IN EITHER FLOW DIRECTION, WITHOUT LOSS OF PERFORMANCE.

COMPETITION

SEND WATER THE WRONG WAY THROUGH AN ORDINARY TRV, AND IT'LL RATTLE. WHO NEEDS THAT KIND OF PRESSURE? FIT THE NEW MYSON TRV 2-WAY, AND ENJOY A QUIETER LIFE.

RATTLED



MYSON
TRV 2WAY



Available in Polished Chrome, Satin Brass or Nickel finishes, in a full range of sizes. For more information contact Myson Heating Controls Ltd, 2002 Castle West, Co Limerick. Tel: 069 - 62277. Fax: 069 -62448; email: enquiries@myson.ie Website: www.myson.ie

'Looks Stunning and Out Of All Proportion To Its Price'



Stelrad Compact Style

The new Stelrad *Compact Radiator with Style* from Davies Ltd bridges the gap between standard radiators and the more expensive designer models. If you are working to a tight budget but require a radiator that is different, and can add a new

dimension to a room, then the Stelrad *Compact With Style* is the solution.

Stunning good looks are combined with the quality and performance you would expect from Stelrad, the UK's No:1 radiator manufacturer.

Stunning good looks



Stelrad Compact Lo-line

are not the only feature to the Stelrad *Compact With Style*. There are eight height options available, from 200mm up to 240mm, for maximum application flexibility.

There are 44 models in the standard range, with heights of 300mm, 500mm and 600mm and lengths from 400mm to 2000mm.

For applications where space utilisation is more difficult, there is a range of 12 vertical models with four heights from 1600mm to 2400mm, and a range of eight Lo-line models with one height of 200mm, and four lengths from 500mm to 2000mm.

With the Stelrad *Compact With Style* Range there is a size and style to fit the most challenging applications.

Underneath the good looks is a radiator guaranteed to provide the superb performance you would expect from the market leader. Strictly controlled independent laboratory testing ensures that all Stelrad radiators are guaranteed to perform to a maximum working



Stelrad compact vertical

pressure of 116 PSI (8 bar), and conform to BSEN 442, the European standard for radiators.

As a measure of the all-round dependable quality and performance, the Stelrad *Compact With Style* comes complete with a 5-year warranty.

Contact: Davies Ltd.
Tel: 01 - 837 6076;
Fax: 01 - 837 2863.

Design Radiators off the shelf



Never looked so good, never priced so good



Opus 2



Opus 1

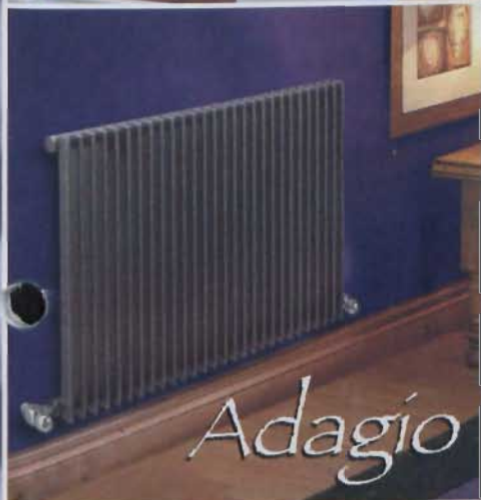

Adagio



Primo



Forza

Concept Kompact 'Plus' Radiator from Heatmerchants

Dedicated to leading the heating industry Heatmerchants are delighted to highlight their new Concept Kompact 'Plus' radiator. This radiator gives an average increase in heat output of 7% greater than its predecessor, the Concept 2000.

But how have Biasi achieved a 7% heat output increase over the remarkable Concept 2000? Actually by changing the fin depth of the radiator by 10 mm — from 30mm to 40mm — the heat efficiency of the radiator increases.

The Concept Kompact 'Plus' is available in two options exclusively from Heatmerchants

- Type 11K: One heat panel and one convector plate.
- Type 21K: Two heat panels and one convector plate.

Both ranges are available in a choice of length and height options to suit all needs. All radiators also come with free top and side cover grills as well as all necessary wall brackets, screws and connections which are now included

in the packaging.

Concept radiators are masterfully designed and made to facilitate their optimum use. They are made in Europe's most advanced radiator factory in Italy, where Biasi are constantly looking at ways to improve their radiators. In support of Biasi's remarkable improvements, the new European Authority for testing the manufacture of radiators has granted the EN442 Part 1 (Test), Part 2 (Quality) approval standard to their complete range of radiators. All Concept Kompact 'Plus' radiators also conform to UNI, ISO, DIN and NF standards.

With its perfectly-sized waterways the Concept Kompact 'Plus' heats up rapidly and at the same time provides protection against blockages. As the convector fins are welded directly to the waterways higher heat efficiency is ensured.

Technical Data in relation to the Concept Kompact 'Plus' is as follows

— Manufactured from

1.25mm cold rolled, fully finished steel;

- Pressure tested to 8 bars, suitable for 6 bar usage;
- Primer coated and finished with super epoxy paint;
- Suitable for use in open or closed indirect heating systems whether single or twin pipe.

The new Concept Kompact 'Plus' still carries Heatmerchants unique 7-year "No Quibble - No Fuss" product guarantee. It also carries Heatmerchants unique

€40 replacement fee should you have to take a radiator off the wall.

Heatmerchants are also pleased to announce their extensive selection of heated towel warmers from Sile which are available in various sizes, colours etc.

Heatmerchants' nationwide branch network takes in Arklow, Athlone, Bray, Castlebar, Cavan, Clonmel, Cork(3), Dublin(4), Dundalk, Dungarvan, Ennis, Galway, Kilkenny, Letterkenny, Limerick, Mallow, Naas, Navan, Portlaoise, Sligo, Tralee, Waterford.

Contact: Heatmerchants Head Office.
Tel: 0902 24000.



The new Concept Kompact 'Plus' from Heatmerchants

**PUSH - FIT VERSIONS
NOW AVAILABLE**

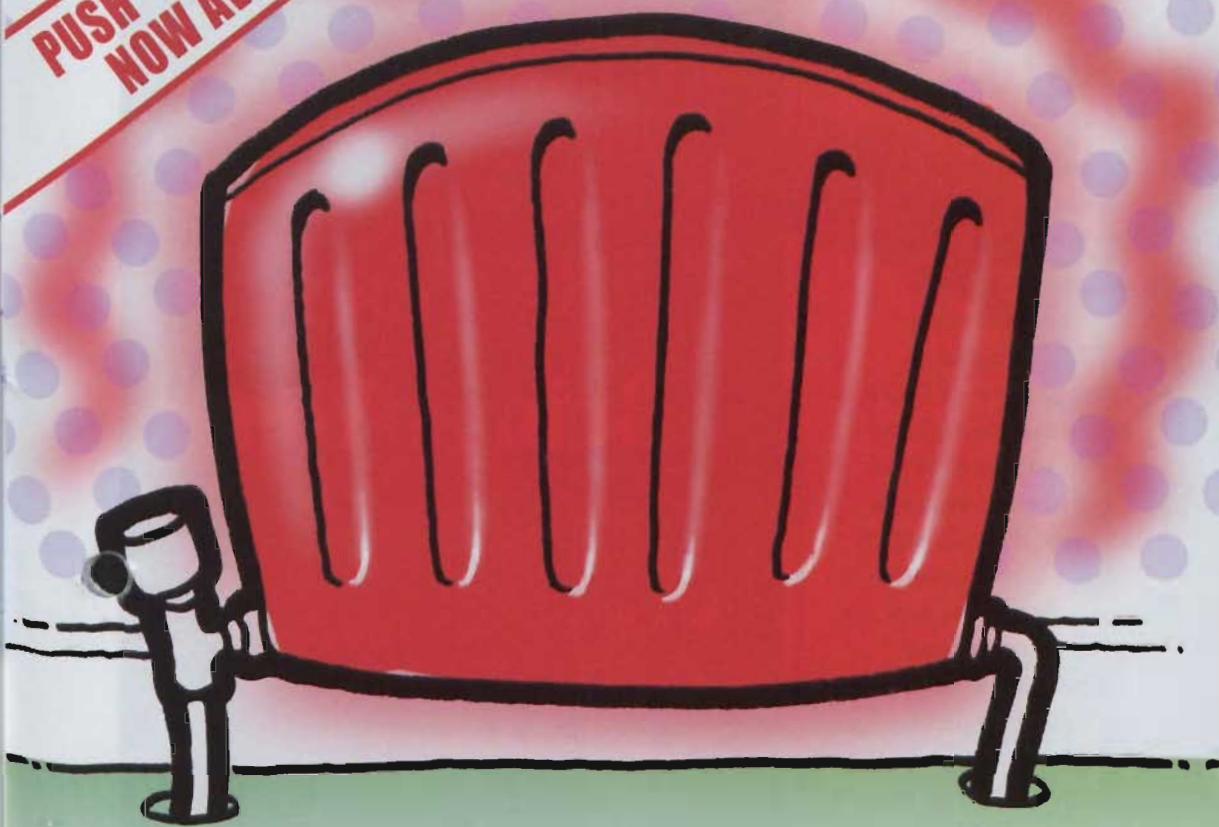

Who's in control when the heat is on?



RAS-D, the domestic radiator thermostat.

Quite simply, your customer is in control when you install Danfoss RAS-D radiator thermostats. No finger crossing, no second guessing.

And the RAS-D radiator thermostat can be installed in either flow or return, vertically or horizontally, with no need to identify flow direction. Simply fit and forget.

Feature by feature, it's out on it's own, saving you time and your customer money, not to mention the all important environmental benefits.

Making good ideas work.

Danfoss

MAKING GOOD IDEAS WORK!



TP5000
The programmable room thermostat



MK18 time controls
The complete time control range



TP5000-RF
The radio controlled range

Danfoss Ireland Ltd. Nangor Road Business Park, Dublin 12.

Published by ARROW@TU Dublin, 2002
Tel: 01 6268111 Fax: 01 6269334

email: marketing@danfoss.ie

Keep Ahead With Honeywell



VT200 from Honeywell

The latest range of Honeywell thermostatic valves includes the chrome-top VT200, as well as the VT15 and VT117. All offer energy savings and reversible flow bodies to give unrivaled performance, individual room temperature control and stylish appearance. Brief details of each are as follows:

VT200 Classic Radiator Thermostat — The Classic appeals to home owners with its modern styling blending with any decor and its stylish chrome-plated cap. It is mountable horizontally or vertically on either the flow or return end of the radiator.

Because the valve body design is not sensitive to water flow direction and its radiator tail and copper tube connections are interchangeable, the VT200 radiator thermostat can be

mounted horizontally or vertically at either end of the radiator without any possibility of water hammer occurring.

VT117E Radiator Thermostat — VT117E is an adjustable radiator thermostat suitable for use in 2-pipe systems. Because the valve body design is not sensitive to water flow direction and its radiator tail and copper tube connections are interchangeable, the VT117 radiator thermostat can be mounted horizontally or vertically at either end of the radiator without risk of water hammer occurring.

VT15 Radiator Thermostat — The VT15 budget-priced radiator thermostat is also fully reversible which has full CEN approval.

V117E Valve body for copper pipework — The V117E valve body is for pumped 2-pipe heating systems with a maximum working pressure of 10bar and is supplied complete with a decorator's cap, adjustable tail, integral, balancing device and 15mm compression fittings.

Contact: C & F
Quadrant.
Tel: 01 - 630 57 57;
Fax: 01 - 630 5715;
email:
sales@cfquadrant.ie

BSNews Brings You

- ◆ New Business Introductions
- ◆ Global Technology Updates
- ◆ News Bites
- ◆ Trend Directions
- ◆ Balanced, informed comment

Subscribe NOW!

Call Louise at

Tel: 01 - 288 5001



All our tubes are up to the Mark

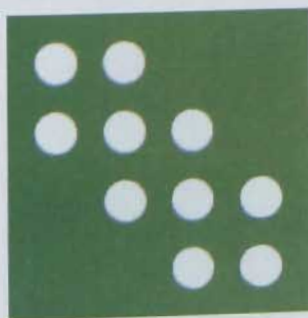

**IRISH METAL
INDUSTRIES**

Irish Metal Industries supply a complete range of copper tube for hot and cold water installations, gas services, sanitation, central heating and numerous other building and engineering applications.

All our tubes are manufactured to the stringent requirements of EN : 1057 and we are licensed to engrave them with the coveted Irish Standard Mark which is the registered mark of the National Standards Authority in Ireland. What's more we give a unique **25 year guarantee** against manufacturing defect. So what ever your requirements you'll receive nothing but the best quality, service and reliability with copper tube from Irish Metal Industries.

Service Line: For orders and further information.

Telephone: (01) 295 2344/295 2137.

Fax: (01) 295 2163

Irish Metal Industries Ltd, 25 Spruce Avenue,
Stillorgan Industrial Park, Blackrock, Co Dublin.

IMI
A subsidiary of IMI plc.

Breakthrough in Energy Saving from Nuaire

The Nuaire Group is a privately owned organisation that has been designing and manufacturing innovative, quality ventilation products for home and overseas markets since 1963. The Group has extensive resources and is constantly growing, employing some 350 people worldwide with an annual turnover approaching €50 million. Redbro Ltd is Nuaire's Irish distributor and they have a long-standing, very successful, trading relationship which has seen both brands emerge as leading players in the air movement sector in Ireland.

Innovation and quality of product are the key elements of the Nuaire portfolio, extensive investment in research and design leading to ground-breaking technology which continuously sets industry benchmarks. A typical case in point is the recently unveiled Ecosmart, a single-source system air movement

management concept which gives total control. Fixed speed fan systems waste energy because their output is matched to a maximum demand which is required only occasionally. The actual demand is often considerably less, in the case of an unoccupied room it could be non-existent.

By automatically adjusting the speed of the fan, Ecosmart matches the output of the system to the demand. The fact that there is a non-linear relationship between speed and power means that the energy saving is disproportionately larger than expected.

Building users and PFI consortia are increasingly demanding more efficient, less costly-to-operate, services.

Reducing speed means motors wear less, increasing their working life – systems working at part load are quieter than those running at full speed – systems which automatically, and continuously, match actual conditions lead to

better air quality.

Frequency inverters and electronic controls enable fan systems to follow changing demand. However, correctly matching the fan, frequency inverter, electronic control and condition sensors is impossible for all but the specialist engineer.

Ecosmart couples the fan to a correctly-matched frequency inverter and electronic control and has available a range of plug-in matched condition sensors. Designers have only to determine the maximum demand and what conditions need to be monitored.

Ecosmart units are generally fitted with EFF2 motors. For even greater efficiencies, EFF1 motors are available as an option. Both EFF1 motors and Ecosmart is pre-wired within its enclosure. The contractor needs only to connect the appropriate sensors and power supply.

Ecosmart, activated by a signal from one or more of the following switching devices, ensures that the system operates only when required:

When a number of switching devices are connected, Ecosmart will respond to any one calling for the system to operate. Multi-connected condition sensors take precedence according to a specified hierarchy:

Ecosmart systems can be interconnected so that they are controlled by the

same switching devices and condition sensors. This is an extremely useful feature when a number of systems serve the same area. When inter-connected, individual Ecosmart units will respond to any switched live devices and/or pressure sensors connected directly to them, otherwise all the connected systems respond as a single unit to other switching devices and condition sensors. Ecosmart enables designers and contractors to easily select and install a fan system which, by automatically adjusting its performance to match the demand, minimises energy consumption of the fan and the ventilated space.

"Reducing energy consumption will become increasingly important as the world attempts to combat global warming", says John Ennis of Redbro. "International aspirations to reduce carbon emissions by reducing energy consumption are already supported in some countries by financial incentives and progressively more demanding regulations. It is a policy which is likely to be introduced by the Irish Government sooner rather than later. In Ecosmart from Nuaire, we already have the solution."

Contact: John Ennis, Redbro. Tel: 01 - 294 0321



Nuaire fan and silencer from Redbro



CONNECTING TRADITION WITH INNOVATION

It could not be easier. The innovative range of metal push-fit fittings for use with copper systems requires a simple push action technique to create installations that you can trust for high quality and durability. If required, the fittings can be readily



disconnected and the joints re-made. They are flame-free, offering high standards of safety and user-friendliness, saving you time and increasing both business efficiency and performance. Copper – the modern solution.

**The Professional Choice
for Plumbing & Heating Systems**

WILO Turns to Nature for Solutions

In outlining the benefits of the new Wilo-Stratos high-efficiency pumps to *BSNews* recently, Wilo Ireland Managing Director Tony Cusack explained that this forerunner to a new generation of wet-running pumps owes its origins to the design and construction principles used in nature. Apparently, a new area of research called bionics — a fast-developing interdisciplinary branch of science bringing together descriptive biology and applied technology — has led to all manner of innovative breakthroughs across many industry sectors. At Wilo they have embraced the principles embodied in bionics with some startling results.

Although there have always been attempts at copying nature, research and science have always tended to accentuate the differences between various disciplines, thereby producing specialists concentrating on one area only.

Today, Bionics specialists working in Germany and in other countries are all bound together in their interdisciplinary approach by a comprehensive philosophy aimed at high-technology applications combined with the conservation of natural resources.

Technology and biology can enter into a marriage of convenience.

For example, the enormous disposal problem created by many of the materials that we use does not exist at all in nature. Anything that was alive decays, in order to be used by new life. There is much to be learned from natural materials in this respect, especially by product manufacturers. Nature is never concerned with records, but always with the optimum solution to the problem. In this way, the course of evolutionary development has thrown up a host of complex and detailed solutions to difficult problems of adaptation. In all these solutions, the overriding premise with regard to the problem in question is efficiency. Using the example provided by nature, many products have already been created and successfully brought to the marketplace. Over the coming months *BSNews* will carry a number of articles illustrating how Wilo has already used the study of bionics — and intends to do so in the future — to develop products that are both energy-efficient and eco-friendly while, at the same time, maximising performance.

In the meantime, featured here are just a few of the amazing examples of unique solutions devised by nature.

SPIDER'S SILK

Even synthetic high-tech fibres, such as those used in bullet-proof vests or to protect astronauts in space, cannot match the amazing properties of the biological fibres produced by the spider. They are stronger than the same thickness of stainless steel, and of course also offer much greater elasticity. The compression strength of the spider's silk is three times as high as that of oak. Because the fibres consist entirely of hydrocarbons, they are also 100% biodegradable.



THE LOTUS EFFECT

The leaves of the lotus blossom unfold in pristine condition from the mud and water in which the plant grows. This phenomenon of self-cleaning comes about because at the microscopic level, the leaf surface is rough, and therefore water-repellent, and is the best known application of bionic experience. Almost all outdoor materials can be cleaned in this way by rain. An exterior wall paint, roof tiles and wood varnishes using this principle are already on the market.



SPEEDY JELLYFISH

The Portuguese Man of War uses an extremely efficient system of movement in order to travel the seas of the world using wind power. It produces a gas bubble, which catches the wind at the surface of the water. Its primitive muscle fibres allow it to raise this sail at an angle of 45°. The highly poisonous tentacles of the jellyfish extend as deep as 50 metres down into the water below. It withdraws the tentacles at regular intervals in order to convey the prey to its 'mouth'. By this means of locomotion, the Portuguese Man of War can achieve a speed of up to ten kilometres per hour – a record speed amongst jellyfish. This could have been the model for the first sailing ships in the world.



DANDELLION PARACHUTE

In order to prevent freefall, the dandelion uses feather-light strands of gossamer, and the parachutist an umbrella of thin artificial silk.

Royal Dublin

Sponsor: Danfoss (Ireland)

Overall Winner	Eamonn Vickers	(10)	33.5 Points
Class 1	Scr 10		
	1 Joe Weafer	(8)	32 Points
	2 Pat Gormley	(6)	30 Points
	3 Tom Noone	(10)	28 Points
Class 2	11-16		
	1 Eamonn Walsh	(11)	32 Points
	2 Vincent Broderick	(11)	31.5 Points
	3 Sean Stenson	(16)	31 Points
Class 3	17-28		
	1 Garvan Evans	(21)	27 Points
	2 Tom Scott	(19)	27 Points
	3 John Duignan	(24)	23 Points
1st Nine Back 9	John White		19 Points
	Brian Kearney		17 Points
Visitor	Gerry Fitzpatrick	(15)	27 Points
Player of the Year	Graham Fay		
Matchplay Champion	Bob Daly		
Runner-up	Michael Wyse		



John Sampson, sponsor, with Pat Gormley (2nd, Class 1) and BTU Captain Des Prendergast



John Sampson, sponsor, with Vincent Broderick (2nd, Class 2) and BTU Captain Des Prendergast



John Sampson, sponsor, with Garvan Evans (1st, Class 3) and BTU Captain Des Prendergast



John Sampson, sponsor, with Tom Noone (3rd, Class 1) and BTU Captain Des Prendergast

Air Enterprises Europe Irish Start-Up



Pat Byrne, Director of Sales with Cathy Ryan, Office Manager, Air Enterprises Europe; Dorothy Gaffney, Chairmain & CEO Air Enterprises Inc; and Edward Gaffney Jr, Managing Director, Air Enterprises Europe

Air Enterprises Inc, one of the leading clean air companies in the US, has set up its European headquarters in Ireland. In what is its first investment outside of the US, the company has located its corporate headquarters in the Nangor Road, Dublin 12, while it has also announced a strategic manufacturing partnership with Carrigaline, Co Cork based Edpac International. All sales, marketing and administrative functions will be housed in Dublin with Pat Byrne as Director of Sales, Air Enterprises Europe, and Cathy Ryan as Office Manager. Pat is widely known throughout the air movement industry in Ireland and Europe where he has worked extensively for leading international companies in the sector. Cathy is also well known in the industry, having worked closely with Pat in recent years.

The company has already received its first order for Ireland from Our Lady's Hospital for Sick Children. The hospital has purchased a custom-built air handling unit for its new €30 million operating theatre suite, which is currently under construction.

Air Enterprises Europe

will invest approximately €5 million over the next four years to establish itself in the European market. This announcement was made by Edward Gaffney Jr, Managing Director, Air Enterprises Europe, during the formal launch of the company in the Merrion Hotel, Dublin 2, recently. Commenting on the decision to locate Air Enterprises Europe in Ireland, he said: "Air Enterprises has been investigating the European and Irish markets for the past 24 months. Our major customers are already here and they have encouraged us to set up an Irish base so that we are closer to their manufacturing plants, and better positioned to continue providing them with the quality engineered product they have grown accustomed to receiving from us."

Air Enterprises Europe has ambitious growth plans for the European market. The company has existing customers in Ireland, Russia, Singapore, Puerto Rico, Saudi Arabia, Japan and throughout the United States. "We are a privately-held, family-owned US company that employs over 150 people. Our 40 years of experience

has taught us that we must continuously expand to meet the growing needs of our valued customers. We have earned a reputation as the experts in solving the most demanding air handling problems and now, to better serve our customers, we are bringing this expertise to the European market," said Mr Gaffney.

"I am confident that locating in Ireland is the right decision for Air Enterprises. Our company has earned a reputation as the international manufacturer of choice in the air handling market and we are now better placed to expand into new markets, European and further afield from our Irish hub. It was also my late father's wish to invest in Ireland and I am very proud to be seeing this project through, on his behalf," said Edward Gaffney Jr.

A native of Tubbercurry in Co Sligo, Edward Gaffney Sr emigrated to the US in the late 1950s. A civil engineering graduate of Manhattan College, New York, he was employed first by Babcock & Wilcox and then McDermott International. During his

22 year career, Edward Sr held senior executive management positions in Barberton Ohio, London, Singapore and Washington, DC. He purchased the Ohio-based, Air Enterprises Inc in 1990 from the founder of the company. An active community leader, Mr Gaffney died suddenly in August of this year at the age of 56.

Air Enterprises Inc is based in Acron, Ohio and specialises in the design and manufacture of customised air handling systems for the healthcare, pharmaceutical, biotech and electronics industries. To date, the company has custom engineered and manufactured over 6,000 uniquely designed units. Customers include, Abbott Laboratories, Bausch & Lomb, Eli Lilly, The National Institute of Health, DuPont, Hewlett Packard, Kodak, NASA, The Cleveland Clinic, Pfizer, Wyeth, Johnson & Johnson and Xerox. Contact: Pat Byrne, Director of Sales, Air Enterprises Europe. Tel: 01 - 429 3195; Fax: 01 - 429 2014; Mobile: 087 206 7710; email: pbyrne@airenterprises.com



The Air Enterprises AHU unit being delivered to Our Lady's Hospital for Sick Children

A reception was held in Jury's Hotel, Ballsbridge, Dublin recently to mark the 10th anniversary of the formation of the Register of Electrical Contractors of Ireland (RECI), the regulatory body for electrical contractors. RECI was established in 1992 by the Minister for Energy at the time, Bobby Molloy TD. The aims and objectives of the organisation are to promote and protect the interests of the public as users of electrical service so that they will obtain an acceptable standard of workmanship and technical competence within the electrical contracting industry, and to provide a high level of assistance to the industry to achieve this standard. The RECI board of directors consists of nominees from the Electro-Technical Council of Ireland, the Electricity Supply Board, the Electrical Contractors Association, the Association of Electrical Contractors of Ireland and elected representatives from registered electrical contractors.

The Commission for Energy Regulation (CER) recently

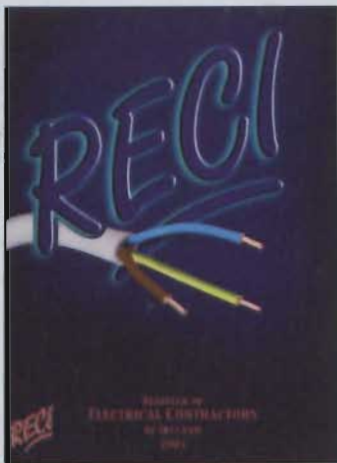

A Complimentary copy of the RECI 2003 Members Directory is enclosed with this issue of BSNews

RECI Celebrates 10 Years of Progress



Standing: Eugene Coughlan, CER with Keane Harley, first Chairman of RECI; Jim Rice, current Chairman of RECI; and David McGloughlin, General Manager;
Seated: Des Kenny, Orchard Electrical with Ms Eleanor Attridge, Elenor Attridge Electrical, and Des Morgan, Mercury Engineering

assumed the role of Supervisory Regulator for the electrical contracting industry, hence the attendance of the Deputy Commissioner for Energy Regulation, Mr Eugene Coughlan, at the RECI reception.

In his address to those present Mr Coughlan traced the history of the formation of RECI and its progress up to the present time. He said that he had been in the Department of Energy when RECI started and now, as Deputy Commissioner for Energy, would be involved in the new phase of development in the industry.

He said that RECI had worked well as a self-regulatory body and that the CER intends to build on this framework for the future. He congratulated the directors and staff of RECI on the excellent progress to

date and wished them continued success in the years to come.

To conclude the evening's formalities Keane Harley, who was the first Chairman of RECI, made a number of presentations to the following electrical contractors who were among the first to be registered in 1992 — Des Kenny, Orchard Electrical; Ms Eleanor Attridge, Elenor Attridge Electrical; and Des Morgan, Mercury Engineering.

There are ten RECI inspectors located around Ireland and their main role is to inspect the work of registered contractors on a regular basis. The inspector visits a number of current or recent electrical installations carried out by the contractor and verifies that the work is in accordance with the Wiring Rules.

If any breaches of the Rules are identified during the inspection the contractor must correct them. In the case of faults which are considered serious from a safety point of view, the contractor may be required to appear before the RECI Disciplinary Committee. The Committee — having heard all the evidence — makes a recommendation to the board of RECI who may suspend, fine or expel the contractor. RECI also recognises the importance of continuing training to keep contractors up to date with changes in the Wiring Rules. Ongoing courses are held in the Training Centre at RECI head office in Dublin, and also at various locations around the country.

It was originally intended that the Chairman of the regulatory body would be appointed by the Department of Energy but unfortunately this did not happen. It was consequently decided that the Chairmanship would rotate between the organisations represented on the board of directors. Ireland's electrical industry is indebted to the following Chairmen who have successfully guided RECI through ten years of progressive development — Keane Harley, ESB; Noel O'Riordan, ETICI; Enda Ryder, ECA; Michael Moran, AEIC; Frank O'Sullivan, Independent Contractors; and Jim Rice, ETICI, the current Chairman.

Contact: David McGloughlin, RECI General Manager.
Tel: 01-492 9966;
email: info@reci.ie

The new range of Quantum Climate Changer units from Trane was designed to be a cost-effective, fast build alternative to welded steel-framed units, while offering significant reductions in overall unit weight but without losing inherent strength, coupled with a sleek clean-lined aesthetic appearance / finish. Units are constructed from an innovative closed box extruded aluminium section framework, with double-wall CFC-free polyurethane foam insulated panels, offering excellent thermal properties and maximum sound reduction through the unit casing. Key features of this design and construction are:

- Unique rigid framework
- Low casing leakage
- Cold bridge free
- Flexible modular construction providing easy on-site build option

The range covers over 30 standard unit sizes from 0.25m³/s to 30.0m³/s, dependent on coil velocity. Non-standard unit sizes are also available to suit sites where access or space is limited.

Quantum Climate Changer units can be tailored to suit most internal and external applications and are manufactured to meet the specific customer requirements. They have also been designed to operate in particularly demanding environments such as hospitals,

New Quantum Climate Changer AHU



The new Quantum Climate Changer AHU from Trane Ireland

pharmaceutical laboratories, coastal and swimming pools. Other typical applications include commercial buildings, leisure centres, shopping centres, hotels and many more.

The Quantum Climate Changer can also be supplied with various energy-efficient and heat recovery packages for different building applications.

All the major types of air to air or fluid to air heat recovery systems such as coil loops, plate heat exchangers, thermal wheels and heat pipes can be incorporated into the unit selection, design and manufacture.

Each Quantum Climate Changer is available with factory-engineered controls that are designed to lower installation costs and risk while dramatically improving the quality of the application. The advantage is strict quality control provided in a world-class manufacturing

environment. The entire air handler control system is engineered, mounted, wired and tested before the unit leaves the factory. Typically, the controls components included in the controls packages are starters; frequency inverters; direct digital controllers; coil valves; damper actuators; temperature, humidity and pressure sensors; frost protection switches; fan air-flow proving; and fan/filter status switches. The control package can be stand-alone air handler operation or can be tied to other Trane products through Trane Integrated Comfort System (ICS), a powerful system architecture that unifies Trane HVAC equipment, direct digital control and building management into a coherent whole with an assured source of support.

Benefits to owners, facilities managers, designers and contractors are:— single source responsibilities; comprehensive

monitoring and diagnostic capabilities; system optimisation resulting in effective operation of entire HVAC system; and allows integration and interoperability through most of the industry standard open communication protocols. That means the following:—

- Control components are properly sized, selected and laboratory-tested for optimal system performance;
- Trained technicians install the controls under ideal conditions using state-of-the-art equipment and wiring practices, eliminating costly conduit and reducing installation time;
- Each air handling unit control system is fully run-tested before it leaves the factory.

A computer-based test station simulates actual operating conditions, supervises the unit controller, drives the actuators and surveys the input and output devices . . . all to help assure trouble-free installation and reliable operation when the Quantum Climate Changer reaches the job site.

Factory-engineered controls provide either stand-alone air handler operation or allows integration into a Trane Tracer Summit Building Management System or any LonWorks controls network.

Contact: Aidan Flannery, Trane Ireland Ltd.
Tel: 01 - 460 6030.

Wastewater Lifting Solutions From Grundfos

Grundfos offers a full range of pumps and systems designed for efficient and reliable wastewater removal from all types of scales and applications. This covers the safe pumping of effluent, drainage and sewage — including aggressive, corrosive liquids — from any situation such as a small 1- or 2-storey family home through to blocks of apartments, camping sites, hotels, hospitals and conference centres.



The Grundfos wastewater range is extensive and caters for all conceivable applications

System reliability is the highest priority, hence the significant sums invested in perfecting the range to ensure robust, virtually maintenance-free systems that will give optimum performance over many years. The range comprises a variety of models from small, one-source units to dual pump systems with volume capacities up to 1200 litres.

All models incorporate state-of-the-art technology and straightforward thinking to provide simple solutions to what are often very complex problems. They are also designed to provide full installation flexibility and reduced operating costs while, at the same time, optimising

operating efficiency.

For instance, to avoid costly construction work the Grundfos submerged pumps can be installed permanently in several different ways to suit each particular environment.

Alternatively, for spot water removal there is the option of a portable pump.

Additionally, some lifting stations in the range can be wall-mounted or hidden below floor level. All have easily-accessible pipe connections. Made from durable, non-corroding materials, the units are also given a smooth finish to make cleaning easy.

The Grundfos wastewater range caters for every conceivable application, and is

especially suited to critical operations. The catering sector is a particular case in point. In places like restaurants, canteens and professional kitchens efficient wastewater removal is vital. Any kind of breakdown can have serious consequences in terms of lost time, money and business. Moreover, hygiene is all-important.

Enter the Grundfos Multilift MD dual pump system with tank capacity of up to 120 litres. It is available in five different models to suit various applications.

For really large volume handling the Multilift APLD with 400-litre tank is ideal. Due to the possibility of parallel-coupling of up to three tanks, this model has a capacity of up to 1200 litres, while still being easy to install and maintain.

It is mounted with Grundfos heavy-duty cast iron sewage pumps which ensure a high degree of reliability to the whole system.

Full details on the Grundfos wastewater range — including a comprehensive catalogue of both printed literature and information in PC disc format — is available from Grundfos Ireland.

Contact: Gordon Barry, Grundfos Ireland. Tel: 01 - 295 4926; email: gbarry@grundfos.com

KXR-16

Advanced *INVERTER* Technology

MITSUBISHI air conditioning & heat pump VRF systems

Flexible control of heating and cooling from any terminal unit simultaneously, with energy recovery between warm and cool areas.

R407C Zero Ozone Depletion



NEW

**SYSTEMS WITH UP TO
16 CONNECTABLE
INDOOR UNITS**

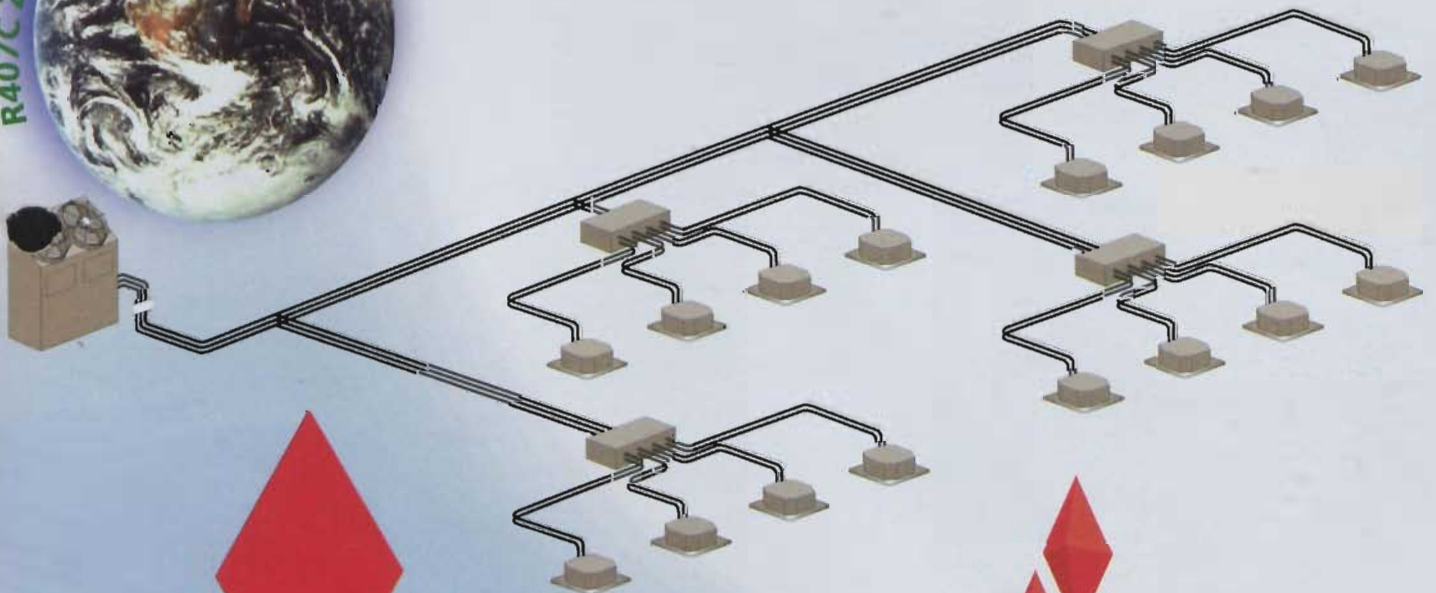

MITSUBISHI
HEAVY INDUSTRIES, LTD.



**3D Air Sales
(Ireland) Ltd**
www.3dair.co.uk

For information
call: Michael Clancy
Tel: 01 450 9433

Gems Sensors the "force" in Water & Waste Management



Manotherm Limited

4 Walkinstown Road, Dublin 12.
Tel: 01 - 452 2355/452 2229; Fax: 01 - 451 6919;
email: manotherm@eircom.net