

7-1-2000

## BS News

Follow this and additional works at: <https://arrow.tudublin.ie/bsn>



Part of the [Civil Engineering Commons](#), [Construction Engineering Commons](#), and the [Construction Engineering and Management Commons](#)

---

### Recommended Citation

(2000) "BS News," *Building Services Engineering*: Vol. 39: Iss. 7, Article 1.

doi:10.21427/D7DB0C

Available at: <https://arrow.tudublin.ie/bsn/vol39/iss7/1>

This Article is brought to you for free and open access by the Journals at ARROW@TU Dublin. It has been accepted for inclusion in Building Services Engineering by an authorized editor of ARROW@TU Dublin. For more information, please contact [arrow.admin@tudublin.ie](mailto:arrow.admin@tudublin.ie), [aisling.coyne@tudublin.ie](mailto:aisling.coyne@tudublin.ie), [vera.kilshaw@tudublin.ie](mailto:vera.kilshaw@tudublin.ie).

# BSN News

et al.: BS News

JULY/AUGUST 2000

MECHANICAL & ELECTRICAL BUILDING SERVICES

- ◆ Heatmerchants ... The Best is Yet To Come
- ◆ Mitsubishi Electric at Mount Juliet
- ◆ Compressor Remanufacturing — More Than Just Lower Cost
- ◆ Hitachi Appoints Season Control



**HEAT EXCHANGERS**  
High-Performance,  
Cost-Effective Solutions

# Innovation in Pumping Technology



MVi



MHi

Stainless Steel Vertical and Horizontal multistage pumps for water supply, boosting, sprinkling, irrigation, high pressure wash, fire protection and water treatment (De-mineralisation, Filtering).

- Water supply
- Boosting
- Sprinkling
- Irrigation
- High pressure wash
- Fire protection
- Water treatment
- Boiler Feed

**WILO**  
Pumping-Perfection

WILO Engineering Ltd., Enterprise Centre  
Childers Road, Limerick, Ireland

Telephone: 061- 41 09 63 Telefax: 061- 41 47 28

# BSNews\*

MECHANICAL & ELECTRICAL  
BUILDING SERVICES

ISSN 0791-0878

Published by:  
Pressline Ltd,  
Carraig Court,  
George's Avenue,  
Blackrock, Co Dublin.  
Tel: 01-288 5001/2/3 Fax: 01-2886966  
ISDN: 01 - 211 2338/9  
eMail: bsnews@pressline.ie

**Editor:** Pat Lehane  
**Advertisement Manager:** Joe Warren  
**General Manager:** Edel Burke

**Origination and Design:**  
Pressline Ltd. Tel: 01 - 288 5001

**Subscription:** One Year — £30

**Printed by:** Kilkenny People.

© All editorial contents and all advertisements prepared by the publishers, Pressline Ltd.

\* Incorporating Irish Heating & Ventilating News.

**Readership Data**

Irish Building Services News (formerly Irish H&V News) is Ireland's only Building Services magazine providing coverage of heating, ventilating, air conditioning, refrigeration, sanitaryware, plumbing, maintenance and environmental industries. It is the only publication catering exclusively for these industries and its circulation includes members of the following:- Chartered Institution of Building Services Engineers (CIBSE); The Mechanical Engineering & Building Services Contractors' Association (MEBSCA); The Association of Consulting Engineers of Ireland (ACEI); The Mechanical Engineering Contractors' Association; The Institute of Domestic Heating Engineers (IDHE); The Registered Heating Contractors Association; The Maintenance, Energy & Environmental Technology Association (MEETA) which incorporates energy managers and maintenance managers;

The Energy Conservation & District Heating Association; The Institute of Plumbing; The Irish Home Builders Association (IHBA); Builders Merchants/Trade Supply Outlets; Irish Property & Facilities Managers Association.

In addition, Irish Building Services News circulates to independent building services contractors and key executives in industry. Government, Semi-State and local authority bodies. Essentially, our circulation is virtually saturation coverage of all those with an interest and/or involvement in the industry.

## Did You Know That ...

- ◆ A long-established distributor is bringing in air conditioning units from Jordan?
- ◆ Ziehl Abegg has renewed an old relationship
- ◆ S&P has been given red hot rating
- ◆ Heatmerchants refreshes the parts other merchants fail to reach
- ◆ York has mini-console split
- ◆ Manothern products have more approvals than they have parts
- ◆ Carrier Aquasnap has given birth to a Junior
- ◆ Toshiba plays it cool
- ◆ Danfoss says take comfort and multiply
- ◆ Wilo has adopted dual role
- ◆ Runtal does it from above
- ◆ 3D Air Sales got a major surprise
- ◆ Heat exchangers poised to take the marketplace by storm
- ◆ Gordon Barry hunts (sort of) with a golf club

Read inside for the full low-down!

IN THIS ISSUE

Heatmerchants Group Profile	2
Mitsubishi AC at Mount Juliet	4
News	6
Compressor Remanufacturing – More Than Just Lower Cost	10
Hitachi appoints Season Control	22
Heat Exchangers offer Multiple Solutions	24
Grundfos Gets the Birdie!	32

## INDUSTRY PROFILE

# Heatmerchants Group ... The Best is Yet to Come!

The Heatmerchants Group needs no introduction to the Irish building services sector. Right from the outset when the company was first established in 1978 by Jim Casey, Eamon Walsh, and the late Larry O'Neill, it has always been a dynamic, progressive organisation. Nonetheless, no one could have foreseen that, 22 years later, Heatmerchants would be the nationwide force it is today, employing over 300 people and operating 24 outlets comprising 12 Heatmerchants branches, 10 Tubs & Tiles outlets, and two Gas & Oil Parts branches, with many more planned for the coming months and years. Heatmerchants' success is based on a handful of critical factors, namely:—

- comprehensive, all-embracing, quality product portfolio;
- multiple-choice, market-leading brands;
- stock availability;
- competitive pricing;
- fast and efficient service;
- nationwide coverage from locally-based branches;



- highly-qualified, fully-trained, local personnel.

Initially, the rate of growth and expansion was steady rather than dramatic. However, the pace of this development increased somewhat in the mid-1990s, and thereafter gathered significant momentum to the current position where the opening of new outlets is now a commonplace occurrence.

The flagship 20,000 sq ft Tubs & Tiles superstore at Fonthill, Liffey Valley in Dublin is undoubtedly Ireland's largest tile and bathroom showroom and is also something of an industry benchmark in respect of the way forward for the industry.

Equally impressive is the rate at which existing outlets continue to be upgraded to reflect modern-day requirements, and of course Heatmerchants' re-designed corporate identity.

Heatmerchants has always been a self-financing organisation but, such was the ambition of its strategic development plan in recent years that outside capital investment was called

for. Coincidentally, Wolsley PLC — the largest builders merchant in the world — was looking to expand into Ireland at the same time. They already had a presence in Ireland through the prior acquisition of Gas & Oil Parts Ltd in 1993. Gas & Oil Parts has now merged into the Heatmerchants Group. Hence the acquisition of the Heatmerchants Group by them in January 1999. Since then implementation of the development plan has accelerated considerably.

While benefitting from the many advantages being part of such a leading market force entails, decision-making is still very much vested in the hands of the Irish management team. This extends right down to international sourcing and purchasing policies.

Turnover for the year-end 1999 was £33 million, the projection for this year being in excess of £40 million. Heatmerchants accounts for approximately two thirds of the company's turnover, the remainder being made up by Tubs & Tiles and Gas & Oil Parts.

In recent years much of the emphasis has been on Tubs & Tiles and, while this will continue, a more concerted focus is now being applied to Heatmerchants and Gas & Oil Parts which have joined forces. Each Heatmerchants outlet will now

## Heatmerchants Management Board

Michael Lucitt – Managing  
 Jim Carey – Finance  
 Brian McTernan – Development  
 Michael O'Brien – Purchasing  
 Charlie Soden – Heatmerchants  
 Macartan McCague – Gas & Oil Parts  
 Pat Roche – Tubs & Tiles  
 Philip Gray – Operations  
 David Bradley – UK-based  
 Keith Jones – UK-based



Exterior view of the expansive new Heatmerchants/Gas & Oil Parts premises at Little Island in Cork.

INDUSTRY PROFILE



Interior view showing the trade counter at Heatmerchants/Gas & Oil Parts premises at Little Island in Cork.

incorporate a Gas & Oil Parts sector, providing more product selection through Gas & Oil Parts expertise in heating and catering replacement parts and controls.

This year has seen two further new developments coming on stream, namely Allwood Flooring and the Tile & Bathroom Factory Outlet concept. Wood flooring was incorporated into the Tubs & Tiles name in 1998 but, because of the unprecedented demand, this side of the business has been given its own distinct profile, rebranded, and is now presented as Allwood Flooring.

The Tile & Bathroom Factory Outlet is a brand new concept for the company. While Tubs & Tiles serves a broad market segment, it does not cater for the discount and budget end of the tile and bathroom sector. This is a very buoyant business and, with Heatmerchants' and Wolseley's combined international purchasing power, sourcing appropriate ranges will not be difficult.

Over the coming 12-24 months the intention is to open five Tile & Bathroom Factory Outlets in Dublin, the first of which is set to open in early August. It is located in Tubs & Tiles former premises in Kylemore Road, Dublin 12, just off the Naas Road.

Plans are now at an advanced stage for the opening of numerous, locally-based Heatmerchants' outlets. The selected locations have been chosen to ensure strategic positioning and thereby strengthen the company's presence in virtually every corner of the country. *BSNews* will carry further details as these branches come on stream throughout the year.

This strategy includes another unique initiative involving "Collect Only" Heatmerchants/Gas & Oil Parts' outlets. As the term suggests, these are more stocking/collection points, where the full product portfolio can be availed. They include showrooms but not a delivery service.

Two such outlets have already opened,

one in Bray and the other at Little Island in Cork. Heatmerchants Naas has just opened in the past week or so, vying for a formidable share of the West/South Dublin market. Additional "Collect Only" outlets will be opened at various nationwide locations over the coming months.

Given the scope and complexity of the overall product portfolio, after-sales service support is of crucial importance to the company. Each branch of Heatmerchants, Gas & Oil Parts and Tubs & Tiles has its own after-sales service person who is available to give the back-up support expected from a professional company in today's demanding market.

Pulling it all together is conducted from Heatmerchants' purpose-designed corporate headquarters in Athlone. This is an ultra-modern, state-of-the-art facility incorporating fully-computerised stock control, invoicing, and logistics controls which are housed in 8,000 sq ft of offices.

The same complex also includes 50,000 sq ft of covered warehousing which is currently being extended to 100,000 sq ft. It too is equipped with state-of-the-art machinery, from mechanical wrapping machines to electronically-operated forklift equipment.

Altogether, the Heatmerchants Group represents a formidable force, not just in building services, but across the full spectrum of the entire construction industry. In just over 20 years it has secured market-leading status ... and this is just the beginning.



Heatmerchants Tralee - L-R: Liam Galvin with Ger McDaid, Orla Slattery, Mary McCarthy, Brian O'Connell and Brendan O'Sullivan.

GOLF OUTING

# Mitsubishi Electric AC at Mount Juliet

Mount Juliet was the wonderful setting for this year's Mitsubishi Electric AC Division annual golf outing. The occasion proved to be an exceptional outing with 50 plus dealers and their guests, enjoying near perfect golfing conditions. As usual, competition was fierce with each of the teams totally committed to winning the much-coveted Mitsubishi Electric Mr Slim Trophy. Nonetheless, Damien Parlour's team of John Finan, Joe Warren and Mike Sheehan were magnificent on the day, running out comprehensive winners with a score of 78pt. Competition was equally-keen for the individual prize with Bill Noone finally clinching it on the back nine with 35pts



Left: Best Back Nine (18pts) — Fergus Madigan, President, Mitsubishi Electric with John Finan, TE Lynskey Ltd; and Michael Sheehan, Manager, Mitsubishi Electric Air Conditioning Division.



Left: Second Prize Overall (32pts) — Fergus Madigan, President, Mitsubishi Electric with Kevin Noonan, Bank of Ireland; and Michael Sheehan, Manager, Mitsubishi Electric Air Conditioning Division.



Above: First Prize Overall (35pts - Won on Back Nine) — Fergus Madigan, President, Mitsubishi Electric with Bill Noone, NUIG; and Michael Sheehan, Manager, Mitsubishi Electric Air Conditioning Division.



Right: Best Front Nine (18pts) — Fergus Madigan, President, Mitsubishi Electric with Raymond Scott, Scott & Noone, and Michael Sheehan, Manager, Mitsubishi Electric Air Conditioning Division.



Left: Fourth Prize Overall (32pts) — Fergus Madigan, President, Mitsubishi Electric with Joe Barrett, Petrogas; and Michael Sheehan, Manager, Mitsubishi Electric Air Conditioning Division.



Above: Team Prize (78pts) — John Finan, T E Lynskey with Fergus Madigan, President, Mitsubishi Electric; Damien Parlour, Tempair; Michael Sheehan, Manager, Mitsubishi Electric Air Conditioning Division; and Joe Warren, BSNews.



Right: Third Prize Overall (33pts) — Fergus Madigan, President, Mitsubishi Electric with Tom McDonald, Refrigeration Engineering Ltd; and Michael Sheehan, Manager, Mitsubishi Electric Air Conditioning Division.

# VENTAC

*\* Air Management Engineers \**

## Acoustic Cabinet Fans – Medium Pressure



Acoustic lined cabinets fitted with medium pressure direct drive centrifugal fans and lined with extra thick acoustic foam to minimise radiated and inlet noises.

**Applications:**

The compact design and low noise levels enables installation in false ceiling applications or any situation where low noise levels are one of the main requirements.

Series – Acoustic box CAB

[www.ventac.ie](http://www.ventac.ie)    [sales@ventac.ie](mailto:sales@ventac.ie)

## Acoustic Cabinet Fans – High Pressure

Acoustic double insulated side panels form the cabinet, which house the direct driven backward curved centrifugal fan. Equipped with IP55, class F motors and are speed controllable using an autotransformer.

**Applications:**

The compact design is ideal for ducted system where high and low noise levels are required. The access panels and the backward curved impeller make cleaning very easy.



Series CVAB

# VENTAC

*\* Air Management Engineers \**

Fitzwilliam House, 11 Fitzwilliam Quay, Ringsend, Dublin 4  
Tel: 01 - 667 1077; Fax: 01 - 667 1055; email: [sales@ventac.ie](mailto:sales@ventac.ie)



TRADE NEWS

# Petra Appoints Finheat

Petra Engineering Industries Co Ltd, the Jordan-based designer and manufacturer of air conditioning, heating, refrigeration and ventilation equipment, has appointed Finheat Ltd as its Irish distributor. Petra's production line covers a large range of standard products, starting with mini split units with capacities of 1 TR to chillers with capacities of 630 TR.

The Petra name is synonymous with quality, all manufacturing procedures being carried out according to the ISO

9001 Quality Management Systems and ISO 14001 Environmental Management System. Products are also stamped with the CE and EMC marks.

Petra has gained the trust and confidence of many corporations worldwide, which have adopted its units as standard in their buildings. Jim King of Finheat is confident that this strength will be equally reflected in Ireland.

Petra rooftop packaged air conditioning units are typical of many highly-efficient installations

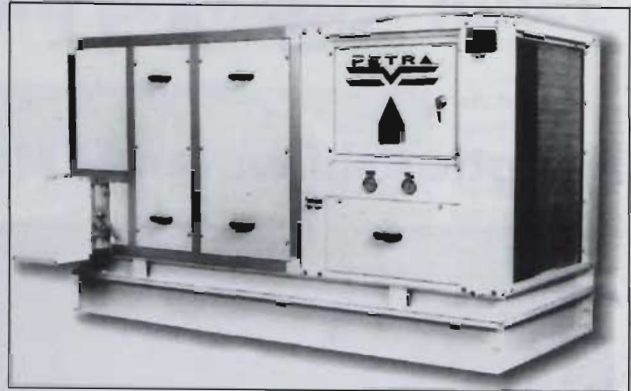

Petra rooftop package from Finheat.

already running in numerous commercial and industrial applications. They are designed for quick and easy installation and can be equipped with optional controls and accessories, reducing installation requirements to a minimum.

They are available in two types, with hermetic (PPH) and with semi-hermetic

(PPS) compressors. Also available with R407C.

The full Petra range includes chillers, packaged units, air handling units, split units, fan coil units, exhaust fans, and heaters.

Contact: Jim King, Finheat Ltd.

Tel: 01 - 623 4222;

Fax: 01 - 623 4226;

email: finheat@indigo.ie

## The World of Ventilation — Control Aer

### THE RANGE

1. Backward Curved Centrifugal
2. Mixed Flow
3. Plate Axial
4. Cased Axial
5. Inline Centrifugal



THE GERMAN  
NAME FOR  
QUALITY, RANGE  
AND VALUE  
IN AXIAL,  
CENTRIFUGAL AND  
MIXED FLOW FANS

ZIEHL-ABEGG 

ZIEHL-ABEGG 

### Stockist & Suppliers

**Control Aer (Cork) Ltd.**  
Unit 12, South Link Park,  
Ballycurreen Road, Co Cork.  
Tel: 021 - 431 8511  
Fax: 021 - 431 8520

**Call Save: 1890 258 456**  
[www.controlaer.com](http://www.controlaer.com)  
email: sales@controlaer.com

**Control Aer Ltd.**  
Kylemore Park North,  
Kylemore Road, Dublin 10.  
Tel: 01 - 626 0177  
Fax: 01 - 626 0434

# smartfit

## A fitting solution...

...to an age old problem

### CENTRAL HEATING CONTROLS INSTALLATION HAS NEVER BEEN AS FAST OR AS EASY AS THIS

The new Smartfit systems from Honeywell overcome the traditional installation problems by using a combination of low voltage wiring and simple plug-in connections. In fact, anyone with basic electrical competence can install a Smartfit system, and with less chance of error. Right first time installation is now a reality, thanks to a revolutionary new system connection box which provides plug-in or simple 2-wire connection for all space heating and hot water controls.



### EASY PROGRAMMING EASY MAINTENANCE

The elegant Smartfit programme controller has been designed to make programming easy. It also incorporates a built-in commissioning sequence, integral manual overrides and a unique diagnostics programme that will highlight any fault in the system.

Smartfit is faster to fit and commission, easier to programme and makes fault identification simple. All time and cost saving features that will improve your productivity and profit margins, offering you the flexibility to be more competitive when pricing the job.

All this, plus the quality and reliability of Honeywell, adds up to happy customers and good business for you.

Find out more from your local merchant, or contact Honeywell Control Systems Limited, Honeywell House, Bracknell, Berks RG12 1EB.

Or call FREE on 0800 521121 Ext 2000.

### FITTING AND PROGRAMMING IS AS EASY AS THIS

1. Install the base unit
2. Snap on the valve power head and plug in
3. Attach the cylinder sensor and plug in
4. Connect the low voltage room unit and switch on
5. Set the programmes for heating and hot water and
5. the Smartfit system is up and running

IT COULDN'T BE QUICKER OR EASIER!



"Energy Efficiency is an initiative backed by the Government."

The Energy Efficiency Hotline 0345 277200

# Honeywell



## MATKI CENTRES

### DUBLIN

Aden Bathrooms;  
Brookfield Builders;  
Davies;  
Bathrooms of Tomorrow;  
GT Garton;  
P H Ross;  
Tullys Tiles;  
Chadwicks Plumb Centre (Stillorgan);  
Waterloo Bathrooms.

### NATIONWIDE

Carlow — P J Nolan;  
Cork — Tile Choice;  
Drogheda — Bathrooms 2000;  
Ennis — Ennis Supply;  
Letterkenny — James Johnston;  
Limerick — Abbey Heating;  
Navan — Versatile Bathrooms & Tiles;  
Tuam — Tuam Heating & Plumbing;  
Tullamore — Walsh Bros;  
Wicklow — Absolute Bathrooms, J P Hopkins.

### NORTHERN IRELAND

Bangor — Haldane Fisher;  
Belfast — Beggs & Partners, S C Jebb;  
Coleraine — J McCandless;  
Enniskillen — W J Thompson;  
Lisburn — Plumprite Supplies, Shawmac Ltd;  
Newry — Haldane Fisher Ltd;  
Newtownards — Shawmac Ltd;  
Portadown — P M Bassett.



## Matki Designer Ranges

**B. J. Caraher (Distributors) Ltd**  
**Dorpin House, 29 Belfast Road, Saintfield, Co Down BT24 7EP**  
**Tel: 04897 511071; Fax: 04897 510921;**  
**email: [matki@bjcaraher.co.uk](mailto:matki@bjcaraher.co.uk)**  
**Website: [www.bjcaraher.co.uk](http://www.bjcaraher.co.uk)**

<https://arrow.tudublin.ie/bsn/vol39/iss7/1>  
DOI: 10.21427/D7DB00

# S&P High-Temperature Smoke Extract

Solar & Palau has recently added to its successful Maxtemp centrifugal range of extract units. Only launched this year, the high-temperature, smoke extract fans complement and add scope to the unrivalled Maxtemp range. All fans in this new range are rated for 400°C for two hours.

The centrifugal fan box (CVHT) can be installed outside the fire-rated areas, or on the outside of the building. Applications: commercial/industrial kitchens, car parks, public

buildings, etc.

The inline cased axial fan (THGT) can be installed inside or outside a building. The adjustable pitch cased axial fan is available in five models, from 500mm to 1250mm diameter. Airflow performances range from 5000 up to 149500 metres cubed/hour. Applications: car parks, shopping malls, public buildings, etc.

Contact: Ciaran King,  
Ventac & Co Ltd.  
Tel: 01 - 667 1077;  
Fax: 01 - 667 1055;  
Email: ctking@ventac.ie



Photo shows Solar & Palau adjustable inline cased axial fan from Ventac.

## Vortice VMC Wins Award

The Vortice VMC Ariant multi-room continuous extract ventilation system from ATC has won the Elex 2000 Product of the Year Award. This unit provides highly-efficient, low-cost ventilation in houses and apartments.

Pictured at the presentation of the Award were Brian Leech, President EMDA; Ciaran O'Reilly, MD, ATC; and Minister Noel Treacy, TD.



## Ziehl Abegg Appoints Control Aer

Ziehl Abegg, one of the biggest manufacturers of fans and motors in Europe has appointed Control Aer to represent them throughout the 32 counties of Ireland.

A sister company of EBM and Kanalfakt Sweden (now t/a System Air), Ziehl Abegg has developed world class products and a complete range to meet every circumstance.

Manufacturing for over 100 years, Ziehl Abegg has been one of the market leaders in Ireland for over 25 years. Renowned for quality with 5-year warranty offers, there are fully operational products in Ireland still functioning after more than 20 years. The average life time expectancy of any Ziehl Abegg product is in excess of 15 years.

Ziehl Abegg has worked with the directors of Control Aer for many years in previous companies and consequently has full confidence in aligning itself with one of the fastest-growing ventilation firms in Ireland at present.

Control Aer will stock the entire range of products in its Dublin and Cork outlets, including plate and cased axials, the revolutionary new cycle blade (hi-performance, low-noise), roof centrifugal and inline duct and mixed-flow duct fans.

Contact: Control Aer, Dublin. Tel: 01 - 626 0177;  
Fax: 01 - 626 0434.  
Control Aer, Cork. Tel: 021 - 431 8511;  
Fax: 021 - 431 8520; email: sales@controlaer.com

## Compressor Remanufacturing More Than Just Lower Cost

Increasing quality standards — combined with undeniable cost benefits — have resulted in compressor re-manufacturing being seen as an attractive option by an increasing number of contractors and end-users. The introduction of guarantees and warranties mean that objections on quality grounds are now difficult

managers and within the commercial sector, ie, supermarket chains, cold storage groups, etc — has increased the need for almost instant reaction in terms of compressor failure. Hence Preston Refrigeration's decision to locate in Ireland.

Among the more established companies in the field, Preston Refrigeration has an enviable reputation within the industry, built upon excellent service and rapid response times. The company boasts a 24-hour turnaround time, from receipt of compressor to complete remanufacture, together with very competitive pricing.

The remanufacturing process is carried out in accordance with ISO 9002, and involves the complete dismantling of each malfunctioning or scrap-ready compressor right down to its cast iron body. Once completely stripped down, the remanufacturing process begins, including motor rewinding, lacquering of the complete rewind motor, replacing worn components with genuine manufacturers parts, through to complete reassembly, repainting and full performance testing. Only then does the compressor find its way into Preston's warehouse, ready for dispatch.

"The cost benefits of a remanufactured compressor compared to a new model can be as much as 66%", says Area Sales Manager, John O'Driscoll. "Our customer base is growing as people come to realise the savings which can be made, and realise that a remanufactured compressor can provide just as good service as a brand new model".

The boom in the remanufacturing industry has meant that prices have become extremely competitive. As a result, Preston has concentrated substantial investment on the introduction of modern technology into areas of the business which reap direct cost advantages to contractors and end users.

Given the price advantages of remanufactured compressors, one could be forgiven for thinking that original compressor manufacturers would be reluctant to assist or endorse products which have been re-manufactured. According to John O'Driscoll, however, the relationship between the two elements of the compressor industry is a very healthy one. "We have had a great deal of support from a number of original equipment manufacturers. Some firms have even

recommended that customers come to us if they are unable to supply certain models themselves".

A measure of Preston Refrigeration's reputation with manufacturers is the fact that the company is regularly called upon to carry out independent tests on compressors returned to other manufacturers or distributors under warranty claims. Preston strips the unit down and produces a comprehensive report on its findings.

The economics of compressor remanufacturing are strongly in the industry's favour and it is not surprising, therefore, that the sector is poised for considerable growth in Ireland over the coming years. "As one of the industry market leaders", says O'Driscoll, "we intend to be at the forefront of this development".

Overall, the economics of compressor re-manufacturing provide the industry with a truly viable, low-cost, high-quality option in the replacement market. However, low price alone is not sufficient to maintain long-term success.

A high level of refrigeration and mechanical engineering



John O'Driscoll, Area Sales Manager, Preston Refrigeration Ltd

to sustain, and also provide companies choosing the re-manufacturing option — possibly for the first time — with a considerable degree of confidence and reassurance.

The growing demand for remanufactured compressors — particularly with facility

COMPRESSOR REMANUFACTURING — MORE THAN JUST LOWER COST

knowledge is demanded of those rebuilding units and buyers should reassure themselves that their chosen supplier is technically competent to carry out a complete remanufacture with proven quality systems firmly in place. Preston Refrigeration in Cork guarantees such a service.

In addition to the replacement of worn components with genuine manufacturers parts, reputable re-manufacturers will also

computer printouts of the results which are then kept as part of the service history of the compressor. Once reassembled at Preston Refrigeration, every rebuilt compressor undergoes a rigorous performance-testing regime to ensure its efficient operation.

Preston Refrigeration in Cork was established specifically to provide a quality compressor re-manufacturing service for Ireland. A team of highly-

has access to the technical support and research facilities of its parent company, along with that of the leading original compressor remanufacturers with whom it has an excellent trading relationship.

So, whatever your compressor problem in Ireland, leave it to the professionals. Contact Preston Refrigeration.

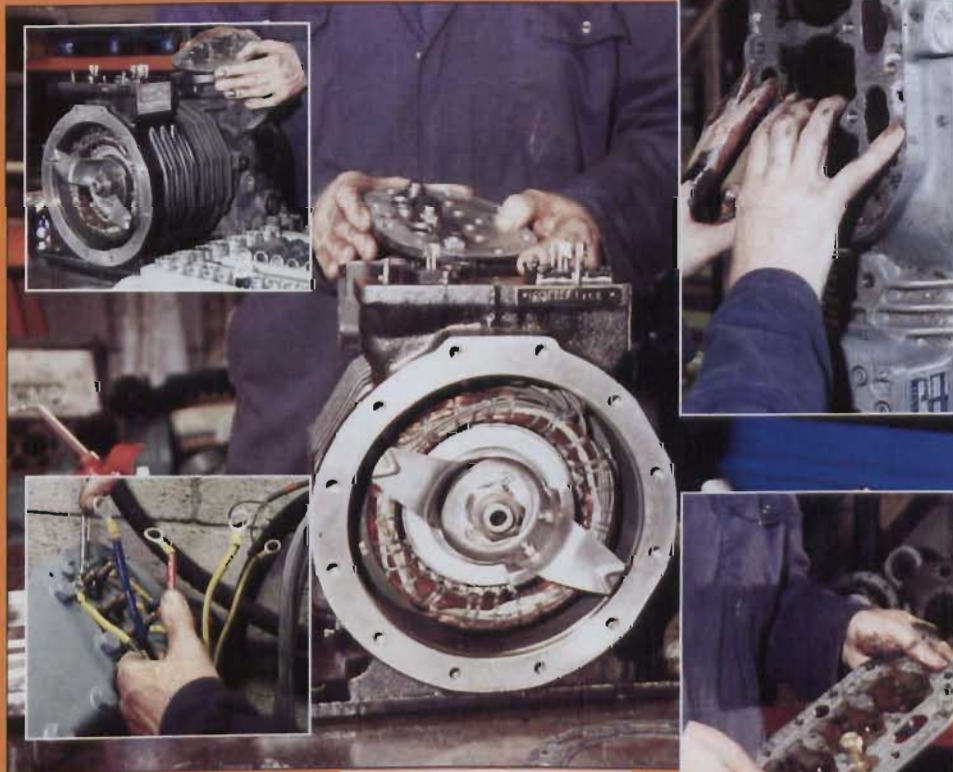

rewind and lacquer the compressor motor as an integral part of the re-manufacturing process. Before being installed back into the compressor, the motor is thoroughly tested using equipment such as a Baker surge-testing machine. Such hi-tech, none-destructive, testing facilities give

skilled, experienced and fully-qualified engineers has been recruited by Area Sales Manager John O'Driscoll and they now operate from a purpose-designed re-manufacturing facility equipped with state-of-the-art equipment. Additionally, the company

## Services Provided

- ◆ Large range of remanufactured compressors from stock
- ◆ Reliability and full back-up
- ◆ Full 12-month warranty
- ◆ Lift and shift
- ◆ On-site troubleshooting to full decommission and recommission
- ◆ All compressors delivered
- ◆ Genuine competitive prices
- ◆ Experienced team of professionals

## Contact

John O'Driscoll,  
**PRESTON  
 REFRIGERATION LTD,**  
 Unit 13B,  
 University Hall  
 Industrial Park,  
 Sarsfield Road,  
 Wilton,  
 Cork.

Tel: 021 - 346400;  
 Fax: 021 - 346189;

## York Launches Minisplit Consoles

York has launched a new range of MCC-MCH minisplit console air conditioning units for use in both commercial and residential properties.

Available in five models and designed for installation in ceiling and floor locations, the new unit has a slimline profile and nominal cooling capacities, ranging from 2.1kW to 8.7kW, and nominal heating capacities ranging from 2.1kW to 9.0kW. Noise levels are said to be extremely low, with a

maximum sound power level for the largest model being just 47 dB(A).

A twin-flap air sweep provides wide angle air distribution which maximises the effectiveness of the unit. A range of operational modes including fan only, cooling, heating and auto enables the system to provide temperature requirements accurately. Additionally, adjustable side vanes provide side to side air control. The units are designed to operate

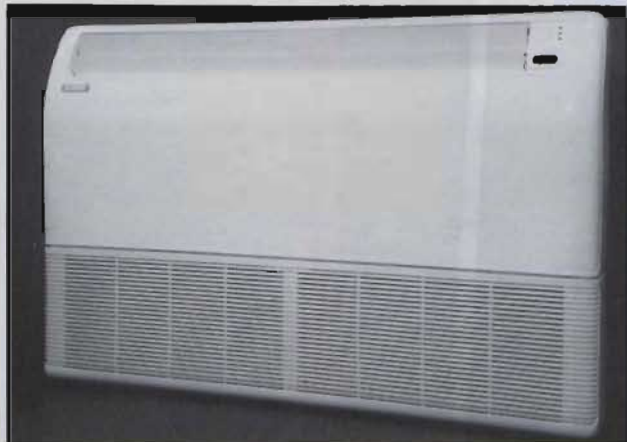

York's new MCC-MCH minisplit console air conditioning unit.

### What Ever Happened to 'Tiefu Fire Dampers?'

A couple of years ago, Tiefu — the only Irish-made, Irish-designed and certified fire damper, was a household name.

A robust fire damper with the only "4 hour" certified rating, Tiefu was manufactured in stainless steel or galvanised, to any dimensions, with full certification to BS476 part 20.

Tiefu is about to be re-launched using the latest technology but under whose banner ... check out next month's edition of *BSNews*.

with minimum maintenance and gas and liquid line connectors can be shaped to suit all connection requirements.

The console utilises York's remote control handset which is available in a wired or wireless

option and features a LDC display. A slide-out control box enclosure also provides easy access to the unit's control system.

Contact: Mark Russell, York. Tel: 01 - 466 0177; Fax: 01 - 466 0198; email: mark.russell@ie.york.com

## Indicator Impervious to Adversity

Proximity Controls stainless steel Mark 1 Position Indicator has more approvals than it has parts. Designed to meet NEMA classifications 1, 2, 3, 3R 3S, 4, 4X, 6, 6P, 7, 9, 12 and 13, the Mark 1 is UL/CSA listed for Class 1, Groups A, B, C, D; Class II, Groups E, F, G, Division 1 and 2; CENELEC listed EEXd11CT6 and IP68, exceeding this by being submersible, indefinitely, to 50 feet.

Built for operation in the most corrosive environments, the Mark 1 has been used in nuclear production and in the testing of space shuttle engines. Current demanding applications include oil tankers and clean rooms. The Mark 1 employs a patented magnetic coupling that totally isolates its switches (and/or transmitter) from the surrounding atmosphere. Housing (with up to three conduit entrances in the base) is 304 SS or 316 SS. Both housing and visual indicator are also available in polished stainless steel.

The indicator's two adjustable windows (56° range/±90° fixed) show OPEN, CLOSED and degrees (0 to 90) in 5° increments on the inner drum, which is adjustable in increments of 15° over the range of 360°. To expedite installation, a flexible bearing on the lower magnet accommodates minor mounting misalignments. Manually adjustable cams actuate mechanical or proximity switches. A simple, single-step rotational cam adjustment includes a locking set screw.

Contact: Bob Gilbert/Brian Harris, Manotherm. Tel: 01 - 452 2355; Fax: 01 - 451 6919; email: manotherm@eircom.com Northern Ireland: Tel: 01820 669936; Fax: 01820 669990; email: sales@manotherm.freeserve.co.uk



Proximity Controls Mark 1 position indicator from Manotherm.

# New from Sauter

Actuate your Senses with a Sauter Drive

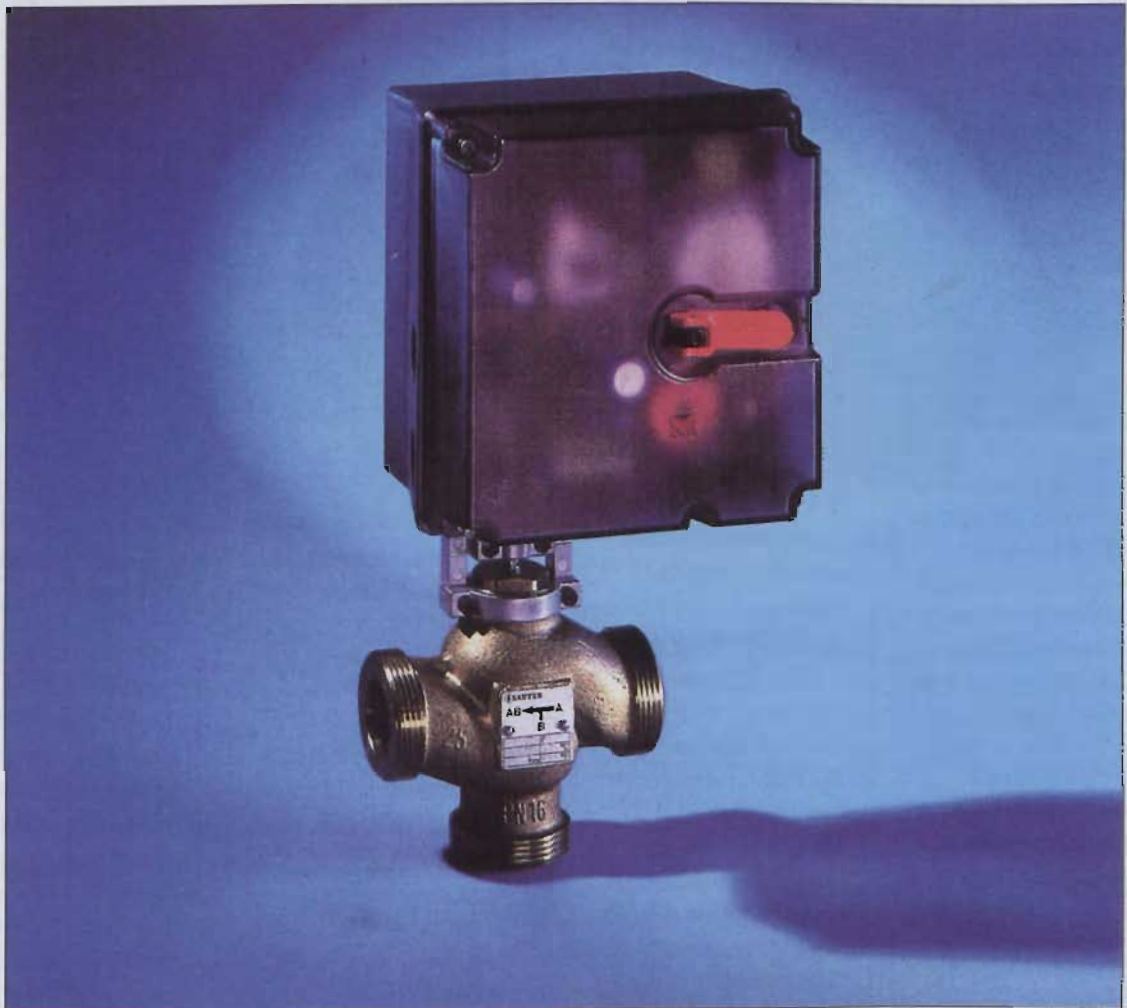

**Just a few reasons why this valve and drive combination are going to revolutionise the HVAC industry worldwide**

#### MANUAL ADJUSTMENT

- ◆ The manual lever on the front of the drive disengages the gearbox and the power supply to the printed circuit board, thereby enabling the required valve position to be selected.
- ◆ There is no need to withdraw the power supply for manual adjustment.

#### L.E.D. INDICATION

- ◆ LED indication informs whether there is power supply at the valve drive, and also the position the valve is in.

#### SIZES

- ◆ Available from 1/2" to 2"

#### INSTALLATION SAVINGS

- ◆ As the valves come complete with Half Unions, the pipework can be brought directly onto the valves. There are large savings to be made in both labour and materials for mechanical contractors.

#### COMMISSIONING

- ◆ With the simple spindle connections, it is not possible to set the drive up in an incorrect fashion. Commissioning time is reduced by up to 50% over any other valve and drive.

#### TECHNICAL SUPERIORITY

- ◆ Both the running times of the drives and the characteristic of the valve (linear, equal percentage, or quadratic) can be selected at the flick of a switch.

ELECTRO PNEUMATIC & HYDRAULIC  
**EPH**  
CONTROLS

**SAUTER** **COMPONENTS**

Switzerland

5 Doughcloyne Court, Doughcloyne Industrial Estate, Wilton, Cork.

Tel: 021 - 434 6238; Fax: 021 - 434 1271; email: eph@indigo.le Website: sauter-controls.com



## MFP Eavesmaster

MFP, developers of Eavesmaster — the only complete PVCu fascia & soffit system on the market — have released the redesigned and updated Eavesmaster Product Brochure, containing the entire product and accessory range.

The Eavesmaster Fascia & Soffit System is designed to be extremely cost-effective and easy to install. It has been chosen for use on many prominent prestigious buildings throughout the UK and Ireland. It is guaranteed never to rot, peel, discolour or warp.

MFP products are developed and manufactured to rigid international standards of quality and durability and offer a cost-effective way to ensure a lifetime of reliability.

Contact, MFP Sales Ltd, Lucan, Co. Dublin. Tel: 353 (0)1 628 0696 Fax: 353 (0)1 628 1119

Email: sales@mfp.ie  
Website: www.mfp.ie



## Carrier's Aquasnap Junior

Carrier's new Aquasnap Junior is believed to be the first small chiller on the market designed to operate with refrigerant 410A. This latest addition to the successful Aquasnap hydronic range is available in five sizes with cooling capacities ranging from 5.1 to 11.2kW. It also incorporates the same advanced technical characteristics of the larger models in the range.

Like its bigger 'brothers', Aquasnap Junior has been designed for ease of installation. The chiller comes pre-wired and charged and simply requires power and water connections on site. All critical components such as the circulating pump, expansion tank, regulating valve and safety devices are integrated within a compact casing which is up to 50% smaller than previous units, making it ideal for residential and small office applications.

Carrier's patented Pro-Dialog controller, designed to operate with the largest Global chiller, has been adapted to work with these small machines to ensure maximum efficiency with minimum compressor wear. It dispenses with the need for a buffer tank.

Carrier's fan coil range has also been extended to include a new range of cassettes and high wall



The Carrier Aquasnap Junior is the first small chiller on the market designed to operate with R410A. Details from Core Air Conditioning.

units which ensures that the Carrier hydronic offering is the most comprehensive currently available.

The hydronic cassette is available in six sizes with capacities ranging from 2.4kW to 9kW, and has been designed to meet the stated needs of installers around the world.

Its ultra-quiet operation has been achieved by the siting of the condensate pump in a separate insulated compartment and the incorporation of a newly-designed high-efficiency fan.

Not only does the Carrier 42GW have the ability to introduce up to 10% outdoor air, it offers the option of air distribution on two, three or four sides, while patented motorised louvres ensure uniform cooling throughout the conditioned space. For ease of maintenance, all major components, including the condensate pump and the

coil, may be accessed from within the grille.

The new 42WH high wall unit, with cooling capacities of up to 2.3kW, is ideally suited for installation in hotels, hospitals and apartment blocks. Each unit is fitted with its own controller for easy adjustment of fan speed, operating status and setpoint to maintain localised comfort conditions. A separate hinge-mounted backplate conceals pipework and electrical connections.

Installation of both new ranges is simplified by the factory-fitting and testing of all peripheral components, and removable grilles which facilitate ongoing maintenance.

Contact: Austin McDermott, Core Air Conditioning. Tel: 01 - 294 3110; Fax: 01 - 294 3115; email: coreac@iol.ie Website: ireland@iol.ie/-coreac

## Wilo Dual Pump Management

Wilo has long been associated with the innovation and continuing development of variable speed pumps for building services applications. Twelve years ago it introduced the Star E range, which was the first electronic variable speed circulator of its kind. It comes as no surprise then that the current ranges of Wilo twin-head variable speed pumps are now equipped with a wide range of features other than just automatic speed control.

Wilo offers two ranges of twin-head variable speed pump. The TOP ED is the glandless range of circulators, and the DP-E is the glanded, mechanical seal range of pumps. As standard, all Wilo electronic pumps can be set for constant differential pressure, variable differential pressure, fixed

speed or temperature-related operation.

Information on the various pump settings and operation parameters can be accessed on a large LCD display on the pump head, or via a Wilo IR-Monitor, which is a remote infra-red controller available as an optional extra.

The TOP ED glandless pumps have, as standard on each head, a normally-closed volt-free contact terminal for fault indication, and all pumps over 200 Watts power input also have the facility to be remotely speed-controlled via an external 0 - 10 volt signal. Terminals for an External Off control input are also provided.

With the addition of an "IF Module" (available as an optional extra) fitted in the terminal box of each head, and an interconnecting



Wilo DP-E glanded pump

communication cable, the pump can be set to function in a master/slave arrangement. This facility provides duty/standby operation with automatic fault changeover and automatic cycling of the duty pump after 24 hours running time.

The IF Module also provides a serial digital interface (PLR) for linking to a BMS via an external interface converter. This allows the BMS to control set-point head, pump on/off and setback operation as well as monitoring pump data such as hours run, actual flow rate, power consumption, etc.

The DP-E glanded pump range has all the above features — fault indication, external off, external speed control, master/slave operation, auto changeover,

PLR interface — as standard without the requirement for extra IF modules. In addition, a volt-free contact provides a run signal for BMS. Simply connect the two heads via a 2-core communication cable and the features are available.

The only external criteria for operation of the above features is that both heads of the TOP ED or DP-E pump must be wired with a permanent, individual electrical supply from the main control panel. This feature then dispenses with the need for auto changeover switchgear in the main control panel, as well as thermal overload protection.

Contact: Wilo Engineering Ltd.  
Tel: 061 - 410963;  
Fax: 061 - 414728;  
email: sales@wilo.ie  
Website: www.wilo.com



Wilo TOP-ED glandless IF Module

MITSUBISHI ELECTRIC QUALITY

# Mr. Slim. The Unanimous



Mr. Slim is Ireland's leading range of packaged split system air conditioning products, offering a huge choice of components and configurations for a wide range of applications, from restaurants and bars, to shops and offices - typical cooling capacity up to 28.4kW and heating capacity up to 26kW.

#### Wide choice - to fit your application precisely

With 14 ceiling cassettes, 6 ceiling suspended units, 10 wall mounted units, and 22 ceiling ducted units, there's a Mr. Slim model to provide the optimum "fit" for all your jobs.

#### Environmentally friendly options

The Mr. Slim range includes models using R407C ozone friendly refrigerant. It can also incorporate optional fresh air casements to help keep designated non-smoking areas smoke-free.

#### Excellent control features and options

Mr. Slim puts you in control with a wide choice of control configuration options, via one or multiple controllers, and all models can be interfaced to Building Management Systems.

#### Whisper Quiet

Advanced fan design has resulted in class-leading noise levels down to just 31dB(A).

For further information on the Mr. Slim range contact:

**Freefone 1800 543 210**



# Split Decision.



## TRADE NEWS

## Improved Comfort and Reduced Costs with Danfoss Radiator Thermostats

Thousands of Irish domestic heating systems fall short of achieving optimum comfort levels and economy because they are not equipped with radiator thermostats. One of the simplest, most effective, solutions — and one which offers installers valuable extra earnings, not to mention end-user/customer satisfaction and long-term savings — is to install Danfoss RAS-D

and RAS-C radiator thermostats.

The importance of radiator thermostats is highlighted in the new Building Regulations which state that proper time and temperature controls should be installed in all newly-built houses from July '99. Over the last 10 year's radiator thermostat sales to the estimated number of existing "wet" heating systems suggest

that many homes could still benefit from a simple retrofit, non-electric, upgrade by adding Danfoss radiator thermostats.

Installers should inform customers that international tests and evaluations have identified that for every 1°C of overheating in a house, the cost can be up to 8% on fuel bills.

Danfoss RAS-D and RAS-C radiator thermostats achieve significant additional energy savings by providing accurate, adjustable temperature control of individual

rooms, ensuring warmth where required without necessarily heating the entire house.

Also, extraneous "free" heat from sources such as sunlight, appliances and people in any particular room prompts them to reduce the flow to appropriate radiators, preventing overheating and producing further savings.

Not only this, they enhance comfort through their "seamless" modulating control as opposed to the On/Off action of electro-mechanical room thermostats, which must cycle over wider temperature bands (hysteresis).

Both RAS-D and RAS-C units are supplied in easy-to-handle "combi-packs" containing integral (built-in) sensors and either 15mm or 8/10mm reversible angle valve bodies. The RAS-D is also available with a 15mm/1/2" BSP straight body. Both models snap-lock into position in seconds.

Room temperature control range is 8°-28°C and integral sensors have "frost" settings, plus "positive off" positions that allow radiator removal for redecoration without draining the system. A remote sensor, with up to 2m capillary, is available for the RAS-D. Sensors and valve bodies can be purchased separately.

Contact: Brian Maguire, Danfoss Ireland.  
Tel: 01 - 626 8111;  
Fax: 01 - 626 9334;  
email: sampson@indigo.ie

## Toshiba 'Cooling Only' Super Multi

Many buildings often require only cooling from their air conditioning systems, particularly in retrofit applications. To match this need Toshiba has developed a cooling only version of its Super Multi system offering considerable cost advantages. Further design improvements to the overall SuperMulti concept have also brought an expansion to the capacity and extension to the flexibility of the systems.

The new outdoor units can be sited as far as 100 metres from the indoor units, making the system particularly attractive in the renovation of older 'sixties-style' blocks.

Using the new Toshiba 16:1 interface and the new space-saving slimline multi-controller, all Toshiba SuperMultis can now provide an effective split system for up to 16 individual indoor units. The slimline multi-controller element of the system offers further flexibility in that a redesign has enabled the electric box to be connected to either side of the controller, simplifying installation procedures.

The equipment's green credentials are an added attraction, as it is specifically designed to use R407C. Since less outdoor units than before are required in many instances, energy savings can also be made.

Careful selection of indoor units can enable a wide range of control options to be used, including integration with BMS or Lonworks®.

Contact: Gerry Phelan, GT Phelan. Tel: 01 - 286 4377; Fax: 01 - 286 4310; email: gtphelelan@eircom.net Website: www.gtphelelan.ie

Inset: Toshiba has developed a cooling only version of its popular Super Multi system. Details from GT Phelan.



# Runtal: Heat from Above

Runtal's new ceiling panels are designed to blend in with the decor of the building and allow complete freedom of design where wall or floor space is a premium. The Runtal Ceiling Panel radiates heat from above in a similar fashion to solar radiation. Integral 50mm

that can either blend into the ceiling or create an attractive feature. All fixing and fittings are hidden above the panel so as not to interrupt the Runtal Ceiling Panel's clean lines. Manufactured to individual requirements, the Runtal Ceiling Panel is available with a maximum length of

and cooling periods lead to minimal reaction times, saving energy and ensuring constant comfort.

The Runtal Ceiling Panel operates silently and cleanly, with no air disturbance to circulate dust particles. It is easy to control, totally safe and requires no more maintenance than a central heating radiator. It can be

used in any number of applications across the private and public sectors.

The Runtal Ceiling Panel is a simple, cost-effective alternative to wall-hung or electric-driven heating systems where wall and floor space is of a premium. Streamline looks and a wide range of colours and sizes ensure that it will blend into any environment. Runtal offers a full technical support package to aid choosing and selection.



Runtal Ceiling Panel

thick insulation is fitted causing a convection of heat throughout a room, corridor or hall. Heat is distributed evenly with little variation of temperature, ensuring total comfort.

Radiant ceiling panels are ideal for buildings where floor and wall space is of a premium or where they need to be unobstructed. Hospitals, warehouses, schools and sports halls are some of the buildings that benefit from the use of ceiling panels.

The Runtal Ceiling Panel is constructed from a series of oval-flattened panels

six metres and a maximum width of 853 mm. There is an infinite range of colours to match any environment. Panels can also be linked together in series to make even longer lengths, and the minimum ceiling height required for use is 2.7 metres.

The heat radiated from the Runtal Ceiling Panel is very uniform allowing the total heating of a building and maximum comfort. The low water content required and the relatively high flow rates result in a low inertia and thus a rapid control of temperature. Short heating

## Large Industry Can Make Savings of £30 Million

Large Irish industry could save up to £30 million annually in energy costs through the implementation of staff training programmes on energy awareness. That is according to Brian Sheridan, Irish Energy Centre, who was speaking at the opening of a special energy conference in Mallow recently. The conference was organised by the Irish Energy Centre in cooperation with Golden Vale Food Products Ltd, Co Cork.

Mr Sheridan said that specialised training for staff on issues relevant to energy awareness could help large Irish industry to make substantial cost savings, representing a reduction of 420,000 tonnes in the level of CO2 emissions in Ireland.



Pictured from left to right are: Brian Motherway, Consultant, Irish Energy Centre; Seamus Keating, Leo Laboratories; and Nuala Calnan, Leo Laboratories.

**SOUND SEAL EUROPE™**  
*Signature Series*



*Architectural Wall Panels*



*Selection of Fabrics*

Signature panels are lightweight, colourful, class 'A' fire rated and are available in a variety of models, sizes and fabric selections. Signature panels can be installed easily with a combination of impaling clip and adhesive.

Signature panels are designed as the solution for areas that require noise reduction or reverberation control. There are more than 4000 different Guildford patterns to choose from. All panels are manufactured to order.



*Panel Adhesive*

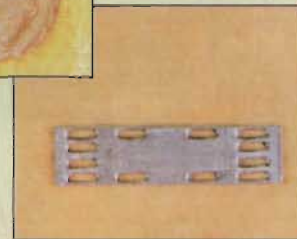

*Impaling Clip*

*Signature Series* • **THE ARCHITECTS' CHOICE**



*Bevel Edge*



*Mitre Edge*



*Radius Edge*



*Square Edge*

## New FDT Cassette from MHI

3D Air Sales (Irl) Ltd now has 18 months trading under its belt. "We set ourselves a relatively ambitious target sales-wise for our first year, however to reach this inside the first four months and more

than double it in 12 months was a surprise even to us", stresses Michael Clancy.

In the beginning people were not quiet sure just who exactly Mitsubishi Heavy Industries were.



The new FDT cassette "8 Series" is one of the quietest on offer today from any manufacturer with a noise rating of only 33Dba.

## Best Builders Merchants Honoured

Ganly's of Athlone is the National Octabuild Builders Merchants of the Year 2000. Now 12 years in business, Ganly's employs 42 full-time and part-time staff in its premises on the Roscommon Road. Ganly's also won the Connaught/Ulster Regional Award.

Builders merchants throughout the country were honoured for their excellence in customer service and management at the awards ceremony in Croke Park recently, where a total of 12 awards were presented by Michael O'Muircheartaigh.

Our photograph below shows Michael Ganly (centre) displaying the Octabuild trophy at the ceremony in Croke Park. He is pictured with Michael O'Muircheartaigh (left) who presented the awards and Tom O'Callaghan, Chairman, Octabuild.



However, after informing them that MHI has a global presence in industries such as shipbuilding, nuclear power station manufacturing, boilers, steam and gas turbines, aircraft and helicopter manufacture, and chemical manufacture, they now understand that it is in fact one of the largest manufactures in the world.

Mitsubishi Heavy Industries has an exceptional reputation for quality and reliability. The design and construction of the air conditioning units also takes into account the difficulties encountered by installation engineers, allowing quick and easy location and fixing of the various units, and simple connection of the electrical supplies and pipework.

The new FDT cassette "8 Series" exemplifies this design culture, even to the extent of providing a fascia panel which can be slightly rotated on the main unit to align accurately with the ceiling grid. The smallest model is only 215mm high. An addition this year to complement the cassette range is a selection of Space Collars, allowing cassettes to be installed in a restricted ceiling depth, while preserving the attractive styling and finish below the ceiling.

The new EDKN "8 Series" wall mounted units are remarkably compact. The 3-section, wrap-around, heat exchanger and new design of fan, improve performance while reducing sound levels. The weight of the indoor unit is approximately 50% of its "6 Series" predecessor.

The FD multi system (capacity up to 28kw) provides a low-cost solution for retail sites and other open-plan areas. Cost savings can also be made in the installation as only one power supply to the outdoor unit is required, and only one pipe run into the building. The extended range of cassettes and ducted units should meet most design requirements.

KX-2 two pipe systems are applied to open plan areas, retail stores, or cellular offices, which would require heating or cooling during the same operational periods.

KXR 3-pipe systems provide the client with a fully-flexible comfort control system, where there is a mixed requirement for some areas to be heated and others to be cooled, eg areas on the north and south sides of a building. Both the KX-2 and KXR offer substantial energy cost savings.

MHI has also developed a range of scroll compressors designed to handle the new ozone benign refrigerants. The new design ensures maximum efficiency while maintaining the excellent standards of high reliability.

3D Air Sales is committed to comprehensive distribution and as such still requires dealers in some parts of Ireland.

Contact: Michael Clancy, 3D Air Sales.  
Tel: 01 - 450 9433/  
087 262 0701; email:  
info@mitsubishi-airconditioning.com  
Website: www.mhi.co.ie



SEASON CONTROL STRENGTHEN PORTFOLIO

# Hitachi Appoint Season Control

Season Control has been appointed a distributor for the full range of Hitachi air conditioning equipment which incorporates a wide range of individual units, coupled with a choice of advanced systems, capable of providing solutions to meet every possible ac application and specification.



Carl Dumpleton, General Sales Manager, Season Control

The vast sums invested in research and development has seen Hitachi introduce many "world firsts", such as the technically-advanced and highly-acclaimed scroll and semi-hermetic screw compressors. These have made possible the unique Hitachi air conditioning systems and water chillers which have revolutionised air conditioning worldwide.

For its part Season Control has also been a dynamic and pioneering force in the Irish air conditioning and ventilation sector. That the two should now join forces in this manner is appropriate and makes for an all-embracing capability on the part of Season Control who can now cater for every conceivable ac and ventilation requirement.

Season Control will make Hitachi available nationwide though its

strategically-appointed dealer network. However, there are a number of regions where additional penetration is being sought and the company invites interested parties to contact Michael Keane who is dedicated to Hitachi sales.

Hitachi caters for every eventuality, from large office complexes to small newsagents and everything in between. Capacities range from 1.6kW through to 70kW and includes room air conditioners, split systems and VRF systems.

Typical examples are Utopia and the hi-multi, set-free VRF systems.

The Utopia range offers a wide variety of models suitable for domestic, commercial and industrial applications. With a choice of five indoor units — 4-way cassette, above ceiling, ceiling suspended, wall and floor mounted — from 5kW to 14.40kW, the Utopia Supercharge

Hi-multi, set-free variable refrigerant flow (VRF) systems are the latest development in advanced air conditioning from Hitachi. Factory designed, built and tested in cooling or heating (2-pipe) and simultaneous cooling and heating (3-pipe) versions they offer the perfect solution for a wide range of applications.

The inherently-quiet Hitachi high-pressure shell scroll compressor, together with factory-fitted acoustic treatment, ensure low noise, vibration-free operation of the outdoor units. Ultra-quiet indoor units and the newly-developed Hitachi soft landing" mechanism for changeover units create the perfect environment.

There is also fuzzy logic" control on cassettes, multiple wiring and piping options, and electronic expansion valves in both the indoor and outdoor units. A wide range of

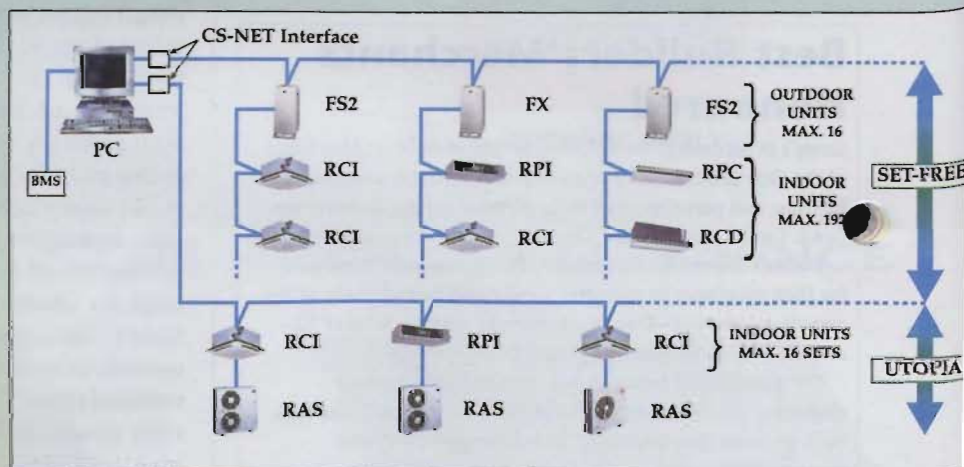

CS-Net controls Set-Free and Utopia systems

range is suitable for almost every application where quiet, reliable air conditioning is required.

Most of the Utopia models have Hitachi scroll compressors giving low noise levels, low vibration and allowing for much longer piping length/lift. The outdoor units are pre-charged to 30m on certain models.

advanced intelligent control options is also available, including the newly-developed Computer Control (CS-NET) Network System which is designed to control an unlimited number of outdoor units.

Contact: Carl Dumpleton, Season Control. Tel: 01 - 456 8200. Fax: 01 - 456 8210. email: season@clubi.ie

## ECO-FREAK



CO2 emissions would be cut by at least 7 million tons every year in Europe!

## SILENT KILLER



No more whistling in the pipes!

## PIGGY-BANK



Up to 40% lower power bills

## FASTER MODEL



Mount the pump and plug it in – and Alpha handles the rest.

GRUNDFOS **alpha**

NOT JUST A PUMP – A NEW STANDARD

HEAT EXCHANGERS

## 'Europak' Fully Packaged Heat Transfer Unit

While Eurofluid Handling Systems is a relatively small company, it has a wealth of in-house experience and technical know-how. Moreover, through its principal trading partners — SWEP, Grundfos and ACV — it has instant access to the enormous resources these multi-national corporations represent.

This is especially true in respect of Eurofluids' Europak fully-packaged heating transfer unit. This unique product is supplied complete with a SWEP gasketed plate heat exchanger capable of recovering the contents of a buffer vessel within a specified time period when supplied primary boiler water. Boiler load available — up to 1 megawatt.

- Europak comes complete with the following:
- Grundfos twin head in-line primary pumpset;
  - Grundfos single in-line bronze circulator type;
  - 3-port lift-and-lay motorised valve with control sensor fitted to buffer return line;
  - All isolating gate valves and non-return valves;
  - Fully prepiped and prewired;
  - Fully-automatic control panel, c/w digital controller, run/trip pump and power-on lamps;
  - Panel-mounted digital temperature indication.

The completely packaged unit is mounted on a common baseframe, primed, painted and tested prior to despatch.

As for the SWEP heat exchangers themselves, these are world-class, highly-compact, high-performance heat exchangers which are based on the corrugated plate concept. By combining various numbers of high-

precision, standardised plate designs into complete, extremely-compact units with various connection configurations and sealing techniques (gaskets, brazing, glue, welding etc), SWEP achieves almost infinite flexibility to meet the needs of each individual customer.

The economical advantages are clear: performance optimised to a particular application, combined with the use of standardised parts and manufacturing procedures, and amazingly-compact design.

SWEP's continuous research and development

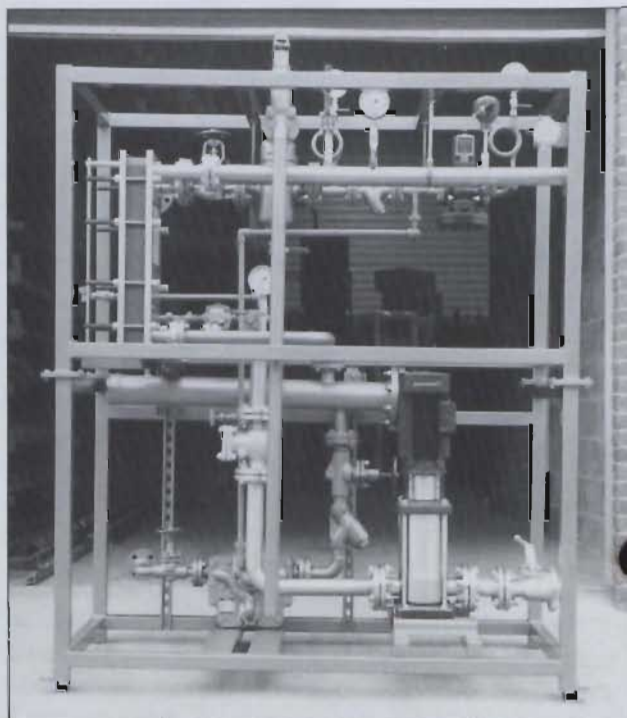

Europak heating and cooling packaged heating transfer unit from Eurofluid Handling Systems.



SWEP's heat exchangers use thin plates of high thermal conductivity, pressed into meticulously-calculated herringbone patterns. Details from Eurofluid Handling Systems.

work is customer-driven, designed to anticipate customer requirements and exceed their expectations. The bottom line for SWEP is to provide tailor-made solutions in a cost-effective manner, using standardised components.

SWEP heat exchangers are typically up to just one-tenth the size of conventional shell-and-tube exchangers for any given performance rating. That means correspondingly less heat transfer medium, smaller pumps; less piping; and less energy consumption.

SWEP is the global leader in compact brazed exchangers (CBEs). It is also a world leader in compact gasketed plate heat exchangers (PHEs). Since the exchangers can be tailored to individual specs, the size of the range is dictated by customers' needs.

Eurofluid Handling Systems will devise a customised solution, whether your request is on HVAC or industrial applications.

Contact: Bernard Costello,  
EHS. Tel: 01 - 450 3884;  
Fax: 01 - 450 7634;  
email: eurofluid@tinnet.ie

**Rycroft**  
HEATING THE WORLD'S WATER

## COMPAC Plate Heat Exchanger Packages



**BSS (Ireland) Ltd**

### DUBLIN

White Heather Industrial Estate, 301 South Circular Road, Dublin 8.

Tel: 01 - 416 5100; Fax: 01 - 416 5165;

email: 1930.sales@bssgroup.com

Published by ARROW@TU Dublin, 2000

### CORK

Unit 20 South Link Park, Ballycurreen Road, Grange, Cork.

Tel: 021 - 321588; Fax: 021 - 321595;

email: 1960.sales@bssgroup.com

HEAT EXCHANGERS

## Fully Packaged Heat Exchangers from BSS – The Rycroft Compac

In today's demanding world of fast-track projects and punishing deadlines, BSS and Rycroft can offer the ideal relief in the form of fully-packaged heat exchanger skids. The units are particularly suited to hospitals, hotels, leisure centres and process applications. Each unit features leading brand name components and are available with:

- Full calendar year programme;
- Auto changeover for dual pumps with hours run check;
- Day and night control;
- BMS on/off control and

secondary temperature monitoring;

- Alarm and monitoring indication;
- Common alarm signal;
- Pressurisation facility available on request.

Although the compac PHE skids are more commonly used with LTHW to DHW applications, variations are available for cooling and steam primary applications.

The Compac comprises a Supapac plate heat exchanger, 4-port control valve, primary pump, temperature sensor, high-limit thermostat and control panel. All are mounted on a factory-built skid, special attention bring

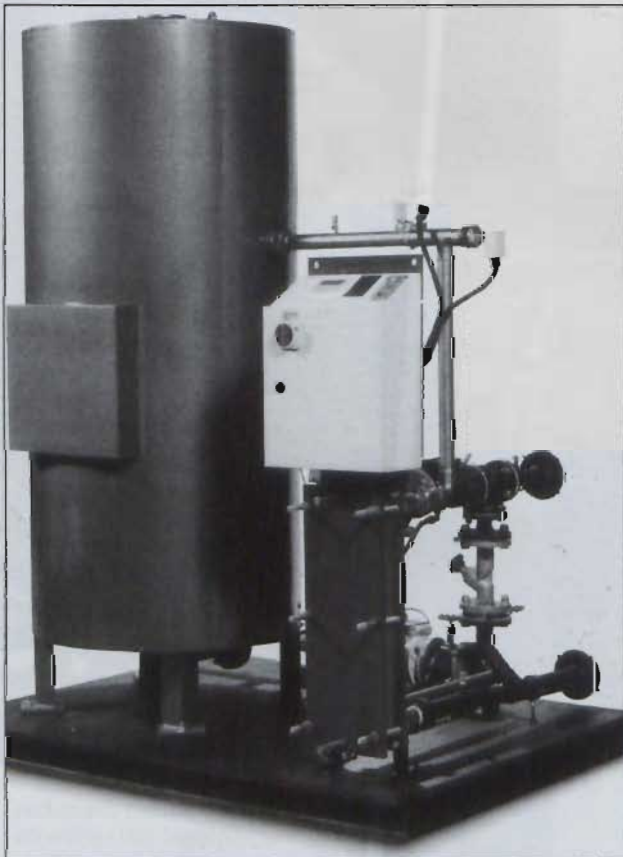

A Compac and buffer vessel is used when water demand is not constant but high flow rates occur frequently. Boiler power requirement is reduced by storing hot water in the buffer vessel for peak demand periods. Details from BSS.



Apart from the standard range of Compac instantaneous water heaters, special designs and standards are available for specific requirements. Details from BSS.

given to appearance with components presented in a professional, painted, finish.

The motorised 4-port valve and primary pump allow rapid adjustment of the heat input to match changes in hot water demand. The 4-port valve mixes cooled primary leaving the exchanger with fresh primary hot water from the boiler to give a controlled primary. This avoids overheating the secondary water, even at zero demand.

The Compac requires no insulation, the design ensuring that the outlet temperature does not fall below 60°C. Consequently, the risk of Legionella growth is reduced. Legionella cannot survive long in water temperatures constantly above 50°C. Indeed, 90% of all Legionella will die after two minutes at 60°C, and the remainder within five minutes.

Compac and buffer vessels: Where required demand outreaches boiler power available, the use of a buffer vessel is the ideal answer. The Compac is available with the buffer vessel mounted on a common skid. This unit also features all necessary interconnecting pipework and insulating for vessel.

To find out more simply provide the class of accommodation and details of the number and type of fixtures. BSS will be happy to recommend the Compac most suitable for your application.

Contact: David Daly and John Quinn, BSS.

Tel: 01 - 416 5100;

Fax: 01 - 416 5165; email: 1930.sales@bssgroup.com

Michael Quinlan, BSS, Cork. Tel: 021 - 432 1588; Fax: 021 - 432 1595; email: 1960.sales@bssgroup.com



# Heat Exchangers



**EHS**  
Eurofluid Handling Systems

Unit 12, The Westway Centre,  
Ballymount Avenue, Dublin 12.  
Tel: 01 - 450 3884/460 0352/460 0353; Fax: 01 - 450 7634;  
eMail: eurofluid@tinet.ie



# HEAT EXCHANGERS

from

## GEA Ecoflex

Gasketed Plate

Brazed Plate

Tubular



Liquid Processing Division

Tuchenhagen Ireland Ltd, GEA Technical Service Division  
Lake Drive, City West Business Campus, Naas Road, Dublin 24  
Tel: 01 - 403 8200; Fax: 01 - 403 8232; email: postbox@geapt.ie



*Our delivery methods can be a little extreme*

**THERMAL**  
Heat Exchanger Systems

Thermal's 20 years of experience producing heat exchangers is the solid basis for supplying Air Cooled Condensers and Dry Air-Liquid Coolers to meet any customer requirement. Where space is at a premium we offer a series of V-shaped condensers and dry coolers with a capacity up to 1650 kW.



HLS AXIS RANGE  
(D.M. 91-9207)

Thermal Heat Exchangers (Irl)Ltd.,  
Newtown, Drogheda, Co. Louth, Ireland.  
Tel: +353 41 9831051 Fax: +353 41 9832117  
Email: thermal@indigo.ie  
UK Agent: Enetech Products Ltd.  
Tel: +44 (0) 1329 317461 Fax: +44 (0) 1329 317461  
Email: info@thermalheat.co.uk



# GEA Heat Exchangers

The GEA range of heat exchangers are represented in Ireland by GEA Tuchenhagen Ireland Ltd. Based in Citywest Business Campus, on the Naas Road, GEA PT Ireland employs 200 staff, primarily involved in engineering design, installation and automation for the process industries. GEA Tuchenhagen Ireland is the sole supplier of the GEA range of heat exchangers to the Irish industry.

The GEA Heat Exchangers Sales — gasketed plate, brazed plate and tubular — are managed by Canice Hanlon, Sales Manager for the Components Division. Canice has more than 10 years experience in the selection of heat exchangers for various industries including energy, HVAC, chemical, refrigeration, and other process-related industries.

The GEA range of plate heat exchangers is manufactured at the GEA Ecoflex plant in Sarstedt near Hanover in Germany where GEA Ecoflex has been manufacturing plate heat exchangers for over 70 years previously under the Ahlborn name).

The GEA Ecobraze range of brazed plate heat exchangers is manufactured at the GEA Ecobraze factory in Landskrona, Sweden (previously under the name Tau Energy Products).

Plate heat exchangers have many applications, particularly in the current "Energy Awareness" climate. Applications for the PHE or BPHE are vast, be it heat recovery or combined heat and power applications. The PHE is an extremely compact design when compared with many other heat exchangers, having high heat transfer values with relatively low pressure drops. The plate

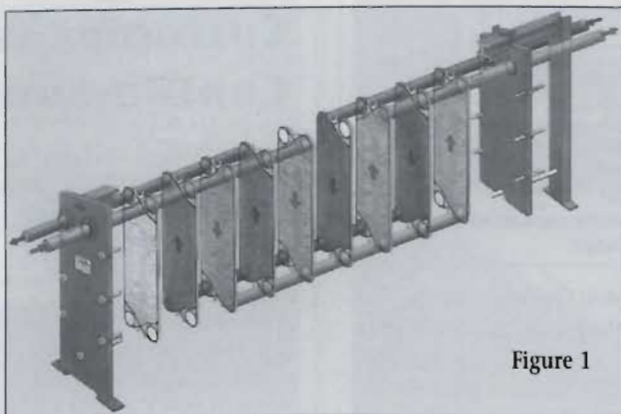

Figure 1

pack can be easily extended or reduced to meet changing capacity demands. They are easily maintained and visually inspected.

The plate heat exchanger, which comprises a number of thin metal plates, compressed and sealed by means of polymer gaskets or copper brazing, is an extremely efficient method of heat transfer. The waste heat or cooling capacity of one fluid or gas is transferred into the other fluid by means of passing the two fluids through the opposite channels of the plate heat exchanger. See Figure 1.

GEA Ecoflex plate heat exchangers can be supplied with glued-in gaskets, or the GEA "Loc In" adhesive-free system, whereby the gaskets are retained in place by means of specially-placed indentations within the gasket groove of the plate.

The GEA Ecoflex gasket has a double seal design with "Tell-Tale Leakage Points".

Should a gasket fail, the double seal on the gasket will prevent any mixing of the media and warn the user of the leak.

To prevent intermixing of the media in the event of plate failure, GEA Ecoflex offers the double-wall plate heat exchanger. The design of the plate is such that a visible indication of the leak is apparent underneath the PHE through the area of atmospheric pressure, thus preventing contamination of one media by the other. Typical applications are for lubricating oil cooling, acid cooling, and turbine or transformer oil cooling.

The GEA Ecobraze range of brazed plate heat exchangers — where primary applications are the HVAC, building services and refrigeration industries — are readily available from GEA Tuchenhagen Ireland.

Typical HVAC applications include tap water heating, central heating, central

cooling, swimming pool heating, heat recovery, secondary heating/cooling systems, under-floor heating, machine cooling, oil cooling, and ceiling cooling.

Typical refrigeration applications include evaporator, condenser, liquid sub-cooler, desuperheater, oil cooler, liquid/liquid, and ammonia applications (by means of special GEA ammonia BPHE range).

GEA has also devised unique solutions to potential problem areas in relation to the use of PHEs in specific applications, especially refrigeration and HVAC. These include:

- The GEA patented Mister (Figure 2): The "Mister" breaks down the droplets in the refrigerant into a homogeneous mist that is well distributed over the plate channels, thereby eliminating the risk of maldistribution;

- The GEA patented PU Foam Insulation (Figure 3): The foam is 100% diffusion tight, CFC-free, 30mm thick and permanently applied to the BPHE. Therefore, there can be no build up of condensate on the heat exchanger;

- The GEA Heating Pad (Figures 4 & 5): The Heating Pad is supplied along with the patented PU-Foam insulation. Both are factory-applied in an integrated design, and eliminate the risk of freezing.

GEA Compact Tubular Heat Exchangers — In addition to the plate range of heat exchangers, GEA also offers tubular exchangers. Primarily designed for heating or cooling of water, by selection of different alloys, the GEA Compact can handle many different applications. The unit is designed with easy removal of the inner tube bundle. The ends are sealed with a double O ring design which compensates for thermal

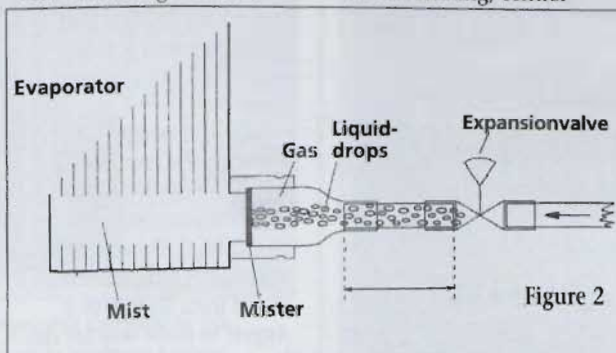
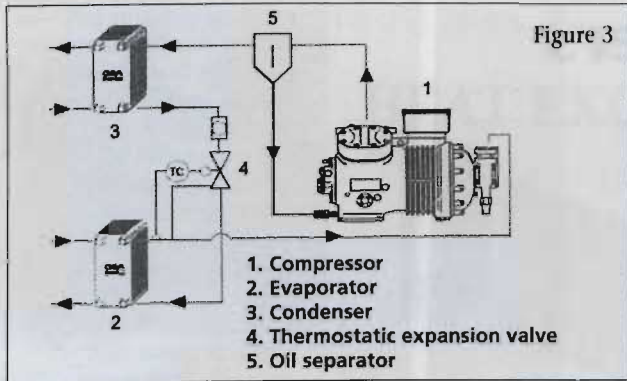

Figure 2



HEAT EXCHANGERS



expansion and contraction. In addition, the unit also has a tell-tale leakage detection area in the event of a leak. The unit can be supplied with 40mm rock wool insulation and stainless

steel cladding. Counter flanges are also available. Contact: Canice Hanlon, GEA Tuchenhagen Ireland. Tel: 01 - 403 8200; Fax: 01 - 403 8232; email: postbox@geapt.ie

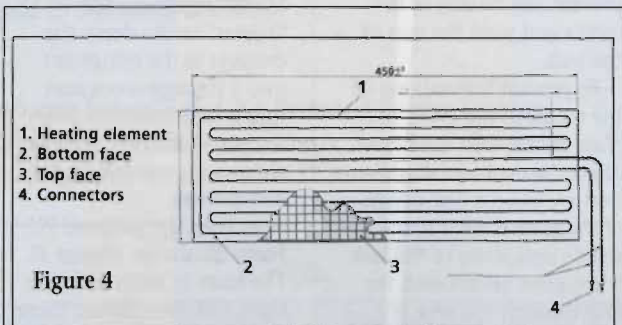

**HAVE YOU RETURNED  
YOUR BUILDING  
SERVICES BUYER GUIDE  
ENTRY FORM YET?  
IF NOT, DO SO NOW!**

## Thermal Heat Exchangers – Creating Customer Value Through Continuous Investment

Thermal Heat Exchangers has appointed Valerie Sorschak to the position of Customer Service Manager, Airside Products. Valerie has extensive experience in marketing, having spent 10 years with a multi-national conglomerate as Marketing Director before joining Thermal Heat Exchangers.

Thermal's expanding business in the condenser market has resulted in a need to fill this very important role. "As the only Irish manufacturer of air-cooled condensers and dry-air liquid coolers, our commitment is that customers in Ireland receive 100% service. Being based in Drogheda makes this an attainable goal", says Valerie. Thermal Heat Exchangers portfolio is extensive. There are six complete ranges of air cooled condensers and dry air liquid coolers, in addition to the standard range. The company also offers a series of V-shaped condensers with up to 1600kW of capacity for more specialised application.

However, Thermal Heat Exchangers is always looking to improve the quality of product and service provided to customers. In recent months in particular, it has undertaken a major reorganisation of the business, involving investment in plant and machinery, and highly-experienced and skilled personnel.

Indeed, Valerie's appointment heralds the commencement of Phase 2 of this investment programme. Thermal Heat Exchangers temporarily closed from 24 July to 4 August to make way for the largest factory re-layout the company has ever seen. The

entire factory floor has been redesigned with the joint collaboration of Enterprise Ireland and Price Waterhouse Coopers. The manufacturing process will go from a departmentalised product layout to a World Class Manufacturing "Pull



Valerie Sorschak, Customer Service Manager, Thermal Heat Exchangers.

System". The new factory will be further supported by an advanced finite scheduling and planning process.

Says Gordon Poots of Price Waterhouse Coopers: "These investments into the factory really underscore Thermal's commitment to stay at the forefront of the Heat Exchanger business".

So what does this mean for Thermal's customers? Cycle times for OEM coils will be reduced from 10 days to one day. Peter McNally, Customer Service Manager for OEM coils had this to say. "The new factory is going to make my job a lot easier. I will now be in a position to offer customers a two-week lead time based on approved drawings".

Thermal Heat Exchangers is the largest coil producer in the UK and Ireland and one of the largest producers in Northern Europe. Finned coil heat exchangers are available

H E A T E X C H A N G E R S



Thermal Heat Exchangers' V-framed condenser

in a variety of fin materials (aluminium, epoxy-coated, hydrophilic-coated, copper, and copper-tinned), 3/8" and 1/2" copper tubing, plain or inner grooved, for single pieces, or OEM-Series.

Apart from computer-based selection software, a highly-specialised "Thermal 3DGEN" automated CAD package is available to generate coil drawings within

minutes.

Thermal is ISO 9001 certified, UL (Underwriter Laboratories) listed, as well as a member of Eurovent.

Contact: Peter McNally (coils); Stephen Rock (condensers and dry coolers), Thermal Heat Exchangers. Tel: 041 - 983 1051; Fax: 041 - 983 2117; email: thermal@indigo.ie

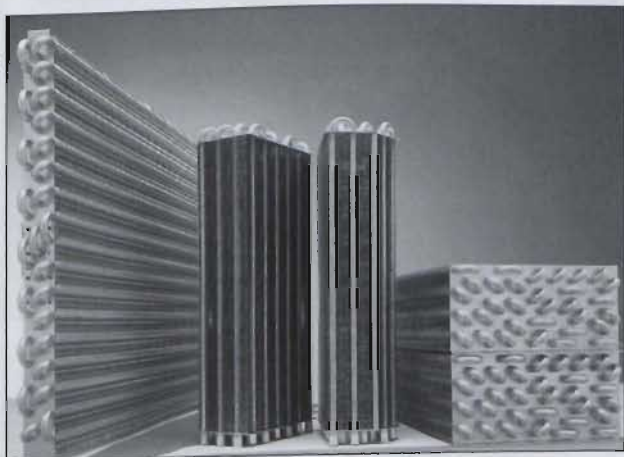

Thermal Heat Exchangers is the largest coil producer in the UK and Ireland, and one of the largest in Northern Europe

**ARE YOU PREPARED TO GAMBLE £700 MILLION BUILDING SERVICES BUSINESS OPPORTUNITY?**



**You Don't Need To**

**To guarantee that your products are specified, and that you share in the profit potential of Ireland's £700 million Building Services Industry, be listed and advertise in the**

**BSNews BUILDING SERVICES BUYER GUIDE**

**CONTACT**

**Joe Warren, Advertising Director  
Tel: 01 - 288 5001;  
Fax: 01 - 288 6966;  
email: joe@pressline.ie**

# Grundfos Alpha – ‘Not Just a Pump, But a New Standard’

Is a pump just a pump? Yes, most would say ... take out the old one and install a new one, job done! In a way, it's true. With Grundfos' new circulation pump, Grundfos Alpha, installing has become easier than ever before.

That's because the pump is automatic. It can figure out the pressure and flow required by the system ... regardless of the building or the time of year. The only thing you need do is to connect it, without even having to open the terminal box!

"That said", says Gordon Barry, General Manager, Grundfos Ireland, "Grundfos Alpha is much more than just a pump. In fact, it's somewhat of a revolution. If all of the old pumps in Europe were replaced with Grundfos Alpha, the saving would equal the annual electricity consumption of 2.5 million family homes. Grundfos Alpha is also much easier on the environment, and there's noticeably less radiator noise.

"At Grundfos, we're in no doubt about it. A pump isn't just a pump. Grundfos Alpha is a completely new way to think about circulation pumps. It's the new standard".

The secret of Grundfos Alpha is its automatic control, which ensures that the pump's pressure and flow is constantly adjusted to meet current needs. To put it another way: Grundfos Alpha automatically adapts itself to summer or winter, night or day.

The automatic control ensures 'communication' between the pump and the heating system's thermostats. In this way the pump adjusts itself to the TRV's required water throughput.

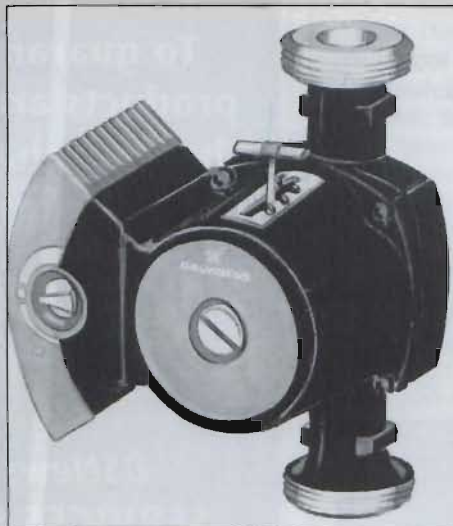

Grundfos Alpha ... not just a pump but a new standard

When there is a high demand for heat, the TRV's valves are wide open, and the pump is hard at work. When the heat demand decreases, the TRV's close accordingly, and the pump works correspondingly less.

Thanks to significantly-lower power consumption, the pump pays for itself within 1 or 2 years. The homeowner can then reap the full benefit of Grundfos Alpha's many advantages for the rest of the pump's useful life ... a period that typically lasts more than 10 years.

Contact: Gordon Barry, Grundfos Ireland. Tel: 01 - 295 4926; Fax: 01 - 295 4739; email: gbarry@grundfos.com Website: www.grundfos.com



Winner, Front 9 — Liam McDermott, Grundfos Ireland, congratulating Jim Casey, Heatmerchants Group

## Gordon Gets a Birdie ... Literally!

Anyone who knows Gordon Barry's golfing prowess will understand why, were he to hit a birdie, it would be front page news. Well, he did hit a birdie during the recent Grundfos Ireland Annual Golf Outing ... the only problem was that the birdie in question was very much alive! In fact it was a swan and, lest you nature lovers get too excited, it merely shook its feathers and tail in Gordon's direction before gliding off majestically on the lake as if nothing had happened.

The Grundfos annual golf outing is now very much established on the building services social calendar. Participants include Grundfos distributors and merchants, along with their invited Grundfos customers.

The venue was Mount Wolseley, near Carlow and, while the day itself was beautiful, the course was playing very long and was totally unforgiving, especially for the novice golfers.

Nonetheless, everyone enjoyed themselves, the proceedings and craic extending well into the early hours of the next morning. The Grundfos hospitality was superb throughout the entire day (save for the swan incident), many availing of the opportunity to stay overnight as guests of the company.



Overall winner Pat Gormley, Patric Engineering, with Gordon Barry, General Manager, Grundfos Ireland

# The Next Generation...

ADVANCED  
**KX-2XR**





**MANOTHERM LIMITED**  
THE CONTROL CENTRES

4 WALKINSTOWN ROAD, DUBLIN 12  
Tel: 01 452 2355/452 2229 Fax: 01 451 6919  
E-mail: [sales@manotherm.freeserve.co.uk](mailto:sales@manotherm.freeserve.co.uk)  
U 15 BANBRIDGE ENTERPRISE CENTRE  
SCARVA RD IND. EST., BANBRIDGE BT32 3QD, CO DOWN  
Tel: 01820 669936 Fax: 01820 669990  
E-mail: [sales@manotherm.freeserve.co.uk](mailto:sales@manotherm.freeserve.co.uk)

# Dwyer®

CONTROLS  
AND  
GAUGES



PRESSURE

FLOW

LEVEL

TEMPERATURE

DWYER

MERCOID

W.E. ANDERSON

LOVE

PROXIMITY

<https://arrow.tudublin.ie/bsn/vol39/iss7/1>  
DOI: 10.21427/D7DB0C

Dwyer Manometers, Magnehelic Gauges,  
Pressure, Level, Flow Switches and Meters