

2006-01-01

## Measured Stark Widths and Shifts of the Neutral Argon Spectral Lines in 4s–4p and 4s–4p' Transitions

Vladimir Milosavljevic

Technological University Dublin, vladimir.milosavljevic@tudublin.ie

Albert R. Ellingboe

Dublin City University

Stevan Djenize

Faculty of Physics, University of Belgrade, Serbia

Follow this and additional works at: <https://arrow.tudublin.ie/schfsehart>

 Part of the [Atomic, Molecular and Optical Physics Commons](#), and the [Plasma and Beam Physics Commons](#)

### Recommended Citation

V. Milosavljevic, et al., (2006) Measured Stark widths and shifts of the neutral argon spectral lines in 4s–4p and 4s–4p' transitions. *Spectrochim. Acta Part B* 61/1, 81-87 (2006) DOI: doi:10.1016/j.sab.2005.11.004

This Article is brought to you for free and open access by the School of Food Science and Environmental Health at ARROW@TU Dublin. It has been accepted for inclusion in Articles by an authorized administrator of ARROW@TU Dublin. For more information, please contact [arrow.admin@tudublin.ie](mailto:arrow.admin@tudublin.ie), [aisling.coyne@tudublin.ie](mailto:aisling.coyne@tudublin.ie).



This work is licensed under a [Creative Commons Attribution-Noncommercial-Share Alike 4.0 License](#)

# Measured Stark widths and shifts of the neutral argon spectral lines in 4s–4p and 4s–4p' transitions

V. Milosavljević<sup>a,b,\*</sup>, A.R. Ellingboe<sup>b</sup>, S. Djeniže<sup>a</sup>

<sup>a</sup> Faculty of Physics, University of Belgrade, P.O. Box 368, Belgrade, Serbia

<sup>b</sup> Dublin City University, School of Physics, Plasma Research Laboratory, Collins Avenue, Glasnevin, Dublin 9, Ireland

Received 12 July 2005; accepted 27 November 2005

Available online 10 January 2006

## Abstract

We investigate the Stark widths ( $W$ ) and the shift ( $d$ ), of the seven neutral argon (Ar I) spectral lines from the 4s–4p and 4s–4p' transitions. The line shapes are measured in a linear, low-pressure, optically thin pulsed arc discharge at about 16000 K electron temperature ( $T$ ) and about  $7.0 \times 10^{22} \text{ m}^{-3}$  electron density ( $N$ ). The new data separates the electron width ( $W_e$ ) and ion width  $W_i$  from the total Stark width ( $W_t$ ), as well the separation of electron total Stark shift ( $d_t$ ) on electron ( $d_e$ ) and ion ( $d_i$ ) parts. There are no theoretical predictions for these lines. Comparison to theoretical predictions for other lines within the same multiplets finds that the experimental data exhibits stronger influence by the ion contribution to the measured Ar I line shape. We have also deduced the ion broadening parameters which describe the influence of the ion static ( $A$ ) and the ion–dynamical ( $D$  and  $E$ ) effect on the width and the shift of the line shape.

Applying the line deconvolution procedure, the basic plasma parameters i.e. electron temperature ( $T$ ) and electron density ( $N$ ) are recovered. The plasma parameters ( $T$  and  $N$ ) are measured using independent diagnostics techniques as well. Good agreement is found among two sets of the  $N$  and  $T$  plasma parameters obtained from deconvolution procedure and independent diagnostics techniques.

© 2005 Elsevier B.V. All rights reserved.

PACS: 32.70.Jz; 52.25.Ya; 52.70.–m

Keywords: Line shapes, widths, and shifts; Neutrals in plasmas; Plasma diagnostic techniques and instrumentation

## 1. Introduction

Argon is one of most frequently used gas in electrical discharges in the last few years driven by the technological applications of plasmas. Determination of plasma parameters through analysis of argon emission would be a powerful tool. In particular, the correlation of plasma internal state to the measured spectral lines is important. Plasma-broadened and shifted spectral line profiles have been used for a number of years, as basis of a non-interfering plasma diagnostic technique. Numerous theoretical and experimental efforts have been made to find solid and reliable basis for this application. This technique became, in some cases, the most sensitive and often the only possible plasma diagnostic tool. Stark broadening in plasmas is important to theoretical understanding as well as for experimental methods, e.g. as a diagnostic tool.

The importance of Stark effects, width and shift is investigated in many papers, i.e. recently in Refs. [1–8]. A significant number of experimental studies [9–30] have been dedicated to the investigation of the Ar I total Stark full-width at half-intensity maximum (FWHM) ( $W_t$ ) and total Stark shift ( $d_t$ ) of the 751.465 nm, 763.511 nm and 772.376 nm spectral lines from 4s–4p transition and 696.543 nm, 727.294 nm, 706.722 nm and 738.398 nm spectral lines from 4s–4p' transition. However, to our knowledge, there are no theoretical predictions for  $W_e$ ,  $d_e$  and  $A$  values for these Ar I lines.

In this paper, we present the measured Stark width and shift of seven (above mentioned) Ar I spectral line (in 4s–4p and 4s–4p' transitions) at plasma conditions of approximately 16000 K electron temperature and  $7.0 \times 10^{22} \text{ m}^{-3}$  electron density. Based on the observed Ar I line profile asymmetry, the characteristics of the ion contribution to the total Stark FWHM ( $W_t$ ) and shift ( $d_t$ ), as expressed by the ion-static parameter ( $A$ ) and the ion–dynamical parameter ( $D$  and  $E$ ) are obtained. The optically thin plasma source used is a linear, low-pressure, pulsed arc operated in three different discharge conditions. We

\* Corresponding author.

E-mail addresses: vladimir@ff.bg.ac.yu, vladimir@physics.dcu.ie (V. Milosavljević).

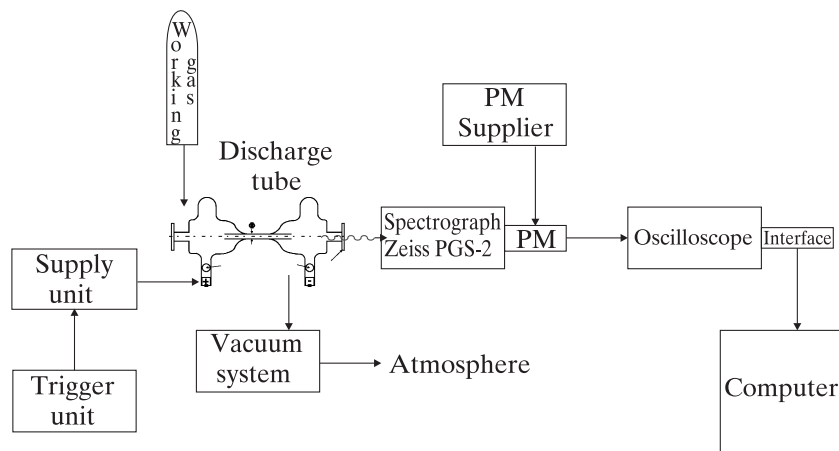

Fig. 1. Experimental setup.

compare our  $W_t$ ,  $W_e$ ,  $W_i$ ,  $d_t$ ,  $d_e$ ,  $d_i$  and  $A$  values to available experimental Stark broadening parameters and indirectly with theory [31,32]. We want to point out that electron temperatures used in our analysis are typical for many cosmic light sources, laboratory and industrial plasmas.

The basic plasma parameters are obtained using the line deconvolution procedure [33,34], i.e. electron temperature ( $T^D$ ) and electron density ( $N^D$ ). This analysis is done for each of the Ar I lines for both helium–argon and hydrogen–argon gas mixtures, and three different discharge parameters. To our knowledge, our results for the  $T$  and  $N$  are the first published data obtained directly from the 751.465 nm, 763.511 nm, 772.376 nm, 696.543 nm, 727.294 nm, 706.722 nm and 738.398 nm Ar I line profiles, using a deconvolution procedure. The same parameters are measured ( $T^{\text{exp}}$  and  $N^{\text{exp}}$ ) using independent, well-known, experimental diagnostic techniques; Good agreement is found between the two sets of the obtained parameters ( $T^D$  and  $T^{\text{exp}}$ ; and  $N^D$  and  $N^{\text{exp}}$ ). This method is suitable for optically thin plasmas. For optically thick plasmas, the situation is more complicated because of very weak asymmetry of the spectral line profile caused by self-absorption.

All Ar I Stark width data presented in Refs. [35–37], refer to the sum of the electron ( $W_e$ ) and ion ( $W_i$ ) contributions to the total Stark width ( $W_t$ ) and to the sum of the electron ( $d_e$ ) and ion ( $d_i$ ) contributions to the total Stark shift ( $d_t$ ) without estimating the contribution of electrons and ions separately. The  $W_e$ ,  $W_i$ ,  $d_e$  and  $d_i$  Ar I values presented here are, to the knowledge of the authors, the first data in the field, with the separate ion and electron contributions evaluated from the measured total Stark width and shift by using the line deconvolution procedure described in Refs. [33,34]. This method was successfully applied [6,38–46] to line profiles of He I, Ne I and Kr I, as well for some other lines of Ar I.

## 2. Theoretical background and experiment

The total line Stark FWHM ( $W_t$ ) and shift ( $d_t$ ) with the corresponding electron  $W_e$  and  $d_e$  and ion  $W_i$  and  $d_i$  contributions are, respectively, given by:

$$W_t = W_e + W_i \quad \text{and} \quad d_t = d_e + d_i. \quad (1)$$

In this way we distinguish between  $W_{t, \text{st}}$  and  $W_{t, \text{s+d}}$  and also between  $d_{t, \text{st}}$  and  $d_t$  are total “static” Stark width and shift, respectively. The “static” means semi-classical theory [31,32]. The  $W_{t, \text{s+d}}$ . The  $W_{t, \text{st}}$  and  $d_{t, \text{s+d}}$ ; are total “static and dynamic” [47] Stark width and shift, respectively.

The  $W_{t, \text{st}}$ ,  $W_{t, \text{s+d}}$ ,  $d_{t, \text{st}}$  and  $d_{t, \text{s+d}}$  can be calculated from the equations[32,47]:

$$\begin{aligned} W_{t, \text{st}} &\approx W_e [1 + 1.75A(1 - 0.75R)] \\ W_{t, \text{s+d}} &\approx W_e [1 + 1.75AD(1 - 0.75R)] \\ d_{t, \text{st}} &\approx W_e [d_e/W_e \pm 2A(1 - 0.75R)] \\ \text{and} \\ d_{t, \text{s+d}} &\approx W_e [d_e/W_e \pm 2AE(1 - 0.75R)] \end{aligned} \quad (2)$$

where

$$R = 6 \sqrt{\frac{36 \cdot \pi \cdot e^6 \cdot N}{(kT)^3}}, \quad (3)$$

is the so-called Debye shielding parameter, i.e. the ratio of the mean ion separation to the Debye radius, where  $k$  is the Boltzmann constant and  $N$  and  $T$  represent the electron density and temperature, respectively.

The applied deconvolution procedure is extensively described in Refs. [33,34,44,48]. It includes an advanced numerical procedure for deconvolution of theoretical asymmetric convolution integral of a Gaussian and a plasma-broadened spectral line profile  $j_{A;R}(\lambda)$ . This method gives complete information on the plasma parameters from a single recorded spectral line. The method determines all broadening ( $W_t$ ,  $W_e$ ,  $W_i$ ,  $d_t$ ,  $d_e$ ,  $d_i$ ,  $A$ ,  $D$  and  $E$ ) and plasma parameters ( $N$  and  $T$ ) self-consistently and directly from the shape of spectral lines without any assumptions or prior knowledge. All one needs to know is the instrumental width of the spectrometer when the spectrometer instrumental width is insignificant compared with the width of any component into which the line profile is separated. Otherwise, a deconvolution for the true instrument function should be calculated as well. The measured profiles are the results of convolution with the Lorentzian Stark and Gaussian profiles caused by Doppler and instrumental broadening [32]. van der Waals and resonance broadenings

Table 1  
Different discharge conditions:  $C$  – bank capacity (in  $\mu\text{F}$ ),  $U$  – bank voltage (in kV),  $H$  – plasma length (in cm),  $\phi$  – tube diameter (in mm),  $P$  – filling pressure (in Pa)

Working gases	Experiment	$C$	$U$	$H$	$\phi$	$P$	$N^{\text{exp}}$ (%)	$N^{\text{D}}$ (%)	$T^{\text{exp}}$ (%)	$T^{\text{D}}$ (%)
72% Ar+28% He	a	14	1.5	7.2	5	133	6.7±7	6.6±12	15.6±11	15.5±12
97% Ar+3% H <sub>2</sub>	b	14	1.5	7.2	5	67	7.0±7	7.1±12	16.0±11	15.9±12
97% Ar+3% H <sub>2</sub>	c	14	1.5	7.2	5	133	7.1±7	7.3±12	16.2±11	16.4±12

$N^{\text{exp}}$  (in  $10^{22} \text{ m}^{-3}$ ) and  $T^{\text{exp}}$  (in  $10^3 \text{ K}$ ) denote experimental electron density and temperature, respectively, obtained at a moment when the line profiles were analyzed.  $N^{\text{D}}$  (in  $10^{22} \text{ m}^{-3}$ ) and  $T^{\text{D}}$  (in  $10^3 \text{ K}$ ) represent averaged electron density and averaged electron temperature obtained by using the line deconvolution procedure [33] applied on the seven Ar I spectral lines.

[32] were calculated and was smaller by more than an order of magnitude in comparison to Stark, Doppler and instrumental broadenings. The deconvolution procedure was computed using the least  $\chi^2$  function [33].

The scheme of our experimental setup is presented in Fig. 1.

The plasma source was modified version of the linear low pressure pulsed arc [49–53]. The working gases are helium–argon (28% He+72% Ar) and hydrogen–argon (3% H<sub>2</sub>+97% Ar) mixtures. Discharges are formed in a quartz discharge tube with expanded end-regions which serve to minimize quartz-wall erosion and sputtering of electrode material onto the viewing windows. The spectroscopic observation of 0spectral lines is made end-on along the axis of the discharge tube. The electrodes are made from brass and carbon. The tube geometry and corresponding discharge conditions are presented in Table 1.

The line profiles are recorded by a step-by-step technique using a photomultiplier (EMI 9789 QB and EMI 9659B) and a grating spectrograph (Zeiss PGS-2, reciprocal linear dispersion 0.73 nm/mm in the first order) system (Fig. 2). The instrumental FWHM of 8 pm was obtained by using narrow spectral lines emitted by the hollow cathode discharge. The spectrograph exit slit (10  $\mu\text{m}$ ) with the calibrated photomultipliers was micrometrically traversed along the spectral plane in small wavelength steps (7.3 pm). The averaged photomultiplier signal (five shots in each position) was digitized using an oscilloscope, interfaced to a computer.

Shot-to-shot plasma reproducibility is tracked by monitoring the Ar I and Ar II line radiation and measurement of the discharge current using a Rogowski coil (it was found to be within  $\pm 5\%$ ).

To check for self-absorption, the relative line intensity ( $I$ ) ratio is monitored during the plasma decay [54] both in standard collection and by doubling the optical path length by placing a mirror on the far end of the discharge tube [48]. Significant self-absorption is found for the 751.465 nm line: approximately 23% in intensity and 9% in line-width; and for the 763.511 nm line: 15% in intensity and 4% in line-width. For these two Ar I lines, corrections on self-absorption are

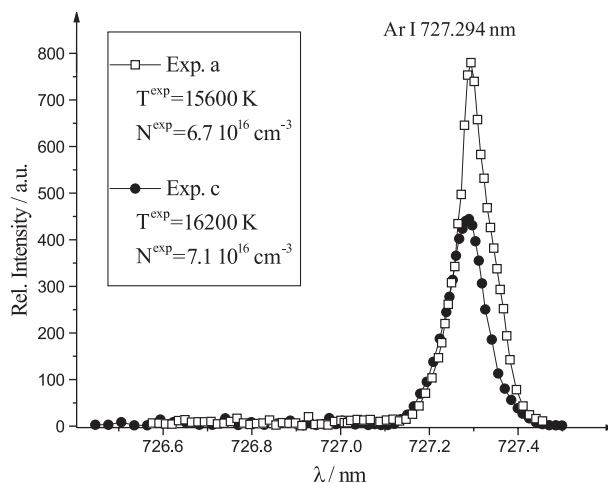

Fig. 2. Recorded profiles of the 727.294 nm line at given  $T^{\text{exp}}$  and  $N^{\text{exp}}$  (see a and c in Table 1). Note – these two spectra have been taken with different voltages on the photomultiplier.

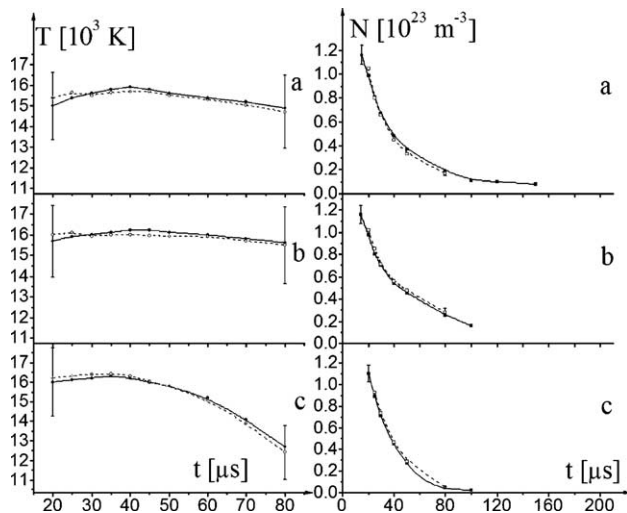

Fig. 3. Electron temperature ( $T$ ) and density ( $N$ ) decays. Full lines represent measured data using independent experimental techniques. Dashed lines represent plasma parameters obtained using our line deconvolution procedure in various plasmas (see a, b and c in Table 1). Error bars represent estimated accuracies of the measurements ( $\pm 11\%$  and  $\pm 7\%$  for  $T$  and  $N$ , respectively) and deconvolutions ( $\pm 12\%$ ).

done. No evidence for self-absorption is found for other five Ar I spectral lines. Namely in the case of 772.376 nm, 696.543 nm, 727.294 nm, 706.722 nm and 738.398 nm, constant relative line intensity ratio is found [54]. Taking advantage of the pulsed discharge; if the ratio of the different lines is found to be constant, then self-absorption can be neglected.

The plasma parameters ( $N$  and  $T$ ) are also determined independently using standard diagnostics methods. The electron

temperature is determined from the ratios of the relative line intensities of seven Ar I spectral lines (415.859 nm, 416.418 nm, 419.103 nm, 419.832 nm, 420.067 nm, 425.936 nm and 426.627 nm) to the five Ar II spectral lines (335.093 nm, 420.197 nm, 426.653 nm, 487.986 nm, 488.903 nm) with an estimated error of  $\pm 11\%$ , assuming the existence of LTE [32]. The necessary atomic data was taken from Ref. [36]. The electron density decay is measured with interferometry using the 632.8 nm He–Ne laser light with an estimated error of  $\pm 7\%$  (Fig. 3).

### 3. Results and discussion

The plasma parameters  $N^{\text{exp}}$  and  $T^{\text{exp}}$  measured independently are presented in Table 1, together with the parameters obtained using the line profile de-convolution procedure  $N^{\text{D}}$  and  $T^{\text{D}}$  (see Eqs. (3) and (8) in Ref. [6]). One can conclude that the agreement among  $T^{\text{exp}}$  and  $T^{\text{D}}$  values is very good (within 3% on average in the three plasmas investigated). This fact confirms the homogeneity of the investigated plasmas in the linear part of our light source (see Fig. 1 in Djeniže et al. [50]). For the electron density, the situation is similar. The agreement among the two sets of values for the electron density ( $N^{\text{exp}}$  and  $N^{\text{D}}$ ) is within the experimental accuracy of 7% and within the uncertainties (12%) of the results obtained by deconvolution procedure. The plasma broadening parameters ( $W_{t, \text{st}}^{\text{exp}}$ ,  $W_{t, \text{s+d}}^{\text{exp}}$ ,  $W_e^{\text{exp}}$ ,  $W_{i, \text{st}}^{\text{exp}}$ ,  $A^{\text{exp}}$ ,  $D^{\text{exp}}$ ,  $d_{t, \text{s+d}}^{\text{exp}}$ ,  $d_{t, \text{st}}^{\text{exp}}$ ,  $d_e^{\text{exp}}$ ,  $d_{i, \text{st}}^{\text{exp}}$ ,  $E^{\text{exp}}$ ) obtained using our deconvolution procedure of the recorded line profiles at measured  $N^{\text{exp}}$  and  $T^{\text{exp}}$  values are presented in Tables 2 and 3 together with those of other authors.

Table 2  
The Ar I line broadening characteristics for lines from transition 4s–4p

Multiplet, $\lambda$ (nm)	$T^{\text{exp}}$ ( $10^3$ K)	$N^{\text{exp}}$ ( $10^{22}$ m $^{-3}$ )	$W_{t, \text{s+d}}^{\text{exp}}$ (pm)	$W_{t, \text{st}}^{\text{exp}}$ (pm)	$W_e^{\text{exp}}$ (pm)	$W_{i, \text{st}}^{\text{exp}}$ (pm)	$A^{\text{exp}}$	$D^{\text{exp}}$	$d_{t, \text{s+d}}^{\text{exp}}$ (pm)	$d_{t, \text{st}}^{\text{exp}}$ (pm)	$d_e^{\text{exp}}$ (pm)	$d_{i, \text{st}}^{\text{exp}}$ (pm)	$E^{\text{exp}}$	Reference	
[3/2] $_1^o$ –[1/2] $_0$ 751.465	15.6	6.7	79.6	70.8	65.1	5.7	0.076	2.55	41.1	33.2	30.0	3.2	3.41	Tw	
	16.0	7.0	85.2	72.4	66.4	6.0	0.078	3.16	44.8	33.4	30.0	3.4	4.34	Tw	
	16.2	7.1	90.5	77.1	70.6	6.5	0.079	3.10	49.0	37.1	34.4	2.7	4.24	Tw	
	10.0	1	7.42				0.044							[9]	
	13.0	10	101											[10]	
	10.3–11.5	2.0–5.0	23–53												[11]
[3/2] $_2^o$ –[3/2] $_2$ 763.511	12.5	10	85.6						17					[12]	
	15.6	6.7	76.3	69.3	65.0	4.3	0.057	2.66	37.8	31.4	29.0	2.4	3.62	Tw	
	16.0	7.0	83.0	72.7	68.1	4.6	0.058	3.27	42.0	33.0	30.2	2.8	4.55	Tw	
	16.2	7.1	84.9	74.1	69.4	4.7	0.059	3.26	43.3	33.9	31.2	2.7	4.52	Tw	
	10.0	1	7.42				0.044							[9]	
	10.3–11.5	2.0–5.0	20–50												[11]
	12.5	10	80.0						20						[12]
	13.0	3.3							21						[13]
	13.8	14.5	146												[14]
	10.0–22.0	2–19	40–180							17–85					[15]
[3/2] $_2^o$ –[3/2] $_1$ 772.376	11.1	0.4	3.8											[16]	
	13.0	3.8	28											[17]	
	15.6	6.7	77.4	70.1	65.6	4.6	0.059	2.66	39.0	32.3	29.8	2.5	3.62	Tw	
	16.0	7.0	84.4	73.7	68.9	4.8	0.060	3.27	43.2	33.6	30.9	2.7	4.54	Tw	
	16.2	7.1	85.5	74.7	69.8	4.9	0.060	3.26	44.5	34.8	32.0	2.8	4.53	Tw	
	10.0	1	6.78				0.042								[9]
12.5	10	70.6						18						[12]	

Measured:  $W_i^{\text{exp}}$ ,  $W_e^{\text{exp}}$ ,  $W_{i, \text{st}}^{\text{exp}}$ ,  $d_{i, \text{st}}^{\text{exp}}$ ,  $d_e^{\text{exp}}$ ,  $d_{i, \text{st}}^{\text{exp}}$  within 12% accuracy at measured electron temperature ( $T^{\text{exp}}$ ) and electron density ( $N^{\text{exp}}$ ). Reference: sources of experimental data; Tw, present data. exp=experimental data; t=total; i=ion; e=electron; st=static only; s+d=static and dynamic.

Table 3

Same as Table 2, but for transition 4s–4p' in Ar I spectrum

Multiplet, $\lambda$ (nm)	$T^{\text{exp}}$ ( $10^3$ K)	$N^{\text{exp}}$ ( $10^{22}$ m $^{-3}$ )	$W_{t, s+d}^{\text{exp}}$ (pm)	$W_{t, st}^{\text{exp}}$ (pm)	$W_e^{\text{exp}}$ (pm)	$W_{i, st}^{\text{exp}}$ (pm)	$A^{\text{exp}}$	$D^{\text{exp}}$	$d_{t, s+d}^{\text{exp}}$ (pm)	$d_{t, st}^{\text{exp}}$ (pm)	$d_e^{\text{exp}}$ (pm)	$d_{i, st}^{\text{exp}}$ (pm)	$E^{\text{exp}}$	Reference	
[3/2] $_2^{\circ}$ –[1/2] $_1$	15.6	6.7	51.9	44.9	41.0	3.9	0.083	2.80	17.5	11.3	9.1	2.2	3.78	Tw	
	696.543	16.0	7.0	58.0	47.8	43.6	4.2	0.084	3.43	21.0	12.0	9.6	2.4	4.73	Tw
	16.2	7.1	57.0	46.9	42.7	4.2	0.084	3.46	19.9	11.0	8.6	2.4	4.78	Tw	
	13.0	10	81						50					[10]	
	13.0–17.0	3.3–5.5							10–18					[13]	
	13.8	14.5	80											[14]	
	11.1	0.4	2.84											[16]	
	13.0	3.8	33											[17]	
	16.5–17.4	60–62	440–490						190–210						[18]
	17.7–18.0	73–82	520–570						220–230						[18]
	18.5–18.7	94–100	590–650						260–260						[18]
	10.2–13.9	1.9–14.7	8–107												[19]
	12.75	10	80												[20]
	13.6–14.6	58–91	580–910												[21]
	15.7–19.0	57–157	390–710												[22]
	13.5–24.0	12.1–19.7	118–185												[23]
	9.7–11.8	1.2–6.0	14–63						5–23						[24]
	10.0–20.0	4.8–19.6	40–140						17–67						[25]
	9.7–12.25	1.2–7.7	8–66												[26]
	11.25–11.9	3.9–6.1	28–43												[27]
13.5–26.5	10	97						26						[28]	
14.0–12.0	20–10	140–80												[29]	
16.8–19.0	57–80	390–510						210–280						[30]	
15.7–17.1	80–160	390–710						230–400						[30]	
16.1–19.6	218–363	1160–2090						510–940						[30]	
16.5–18.7	60–100	440–650						210–280						[30]	
[3/2] $_1^{\circ}$ –[1/2] $_1^{\circ}$ 727.294	15.6	6.7	72.6	64.2	58.9	5.3	0.079	2.57	18.9	11.4	8.4	3.0	3.44	Tw	
	16.0	7.0	78.9	66.7	61.1	5.6	0.080	3.17	20.4	9.6	6.4	3.2	4.35	Tw	
	16.2	7.1	80.2	67.8	62.1	5.7	0.080	3.16	20.8	9.9	6.6	3.3	4.33	Tw	
	13.0	10	89											[10]	
	11.1	0.4	4.39											[16]	
	10.3–12.5	2.0–8.5	18–80												[26]
13.5–26.5	10	96						38						[28]	
[3/2] $_2^{\circ}$ –[3/2] $_2$ 706.722	15.6	6.7	52.9	46.5	43.0	3.5	0.071	2.84	18.7	13.0	11.0	2.0	3.85	Tw	
	16.0	7.0	56.3	47.2	43.6	3.4	0.072	3.52	19.7	11.6	9.6	2.0	4.90	Tw	
	16.2	7.1	58.3	49.0	45.2	3.8	0.072	3.49	22.0	13.7	11.6	2.1	4.84	Tw	
	10.0	1	6.6				0.044							[9]	
	13.0–18.0	3.3–6.6							9–16					[13]	
	13.8	14.5	75											[14]	
	10.3–12.35	2.0–8.0	14–65												[26]
13.5–26.5	10	106						45						[28]	
[3/2] $_1^{\circ}$ –[3/2] $_2$ 738.398	15.6	6.7	63.8	56.5	52.2	4.3	0.071	2.73	21.6	15.0	12.6	2.4	3.70	Tw	
	16.0	7.0	69.2	58.6	54.1	4.5	0.072	3.38	22.6	13.2	10.6	2.6	4.67	Tw	
	16.2	7.1	71.4	60.6	55.9	4.7	0.072	3.34	22.8	13.3	10.6	2.5	4.62	Tw	
	10.0	1	7.06				0.044							[9]	
	10.3–11.5	2.0–5.0	18–42											[11]	
	12.5	10	74.8						11					[12]	
	13.0	3.3							12					[13]	
	13.0	3.3	25											[17]	
13.5–26.5	10	103						42						[28]	

As there are no theoretical calculations for these seven Ar I spectral lines, we compare our results to lines which belong to the same multiplets (and transitions) as our lines. Greim [32] has calculated the values for  $W_e$ ,  $d_e$  and  $A$  using semi-classical theory, which limits the comparison to the static Stark width ( $W_{t, st}$ ) and shift  $d_{t, st}$ . Comparison is made (see Tables 2 and 3) for the measured Ar I 763.511 nm and 772.376 nm total (electron+ion) FWHM  $W_{t, st}^{\text{exp}}$  and shift  $d_{t, st}^{\text{exp}}$  values and the well-known theoretical one Ar I 810.369 nm  $W_t^G$  and  $d_t^G$ .

For the two lines (763.511 nm, 772.376 nm), the measured total Stark width is 20% lower and the total Stark shift is 10% higher than the one calculated by Greim [32]. Generally for these two Ar I spectral lines, the measured electron Stark widths and shifts are smaller than those presented by Griem [32] by about 40% and 25%, respectively. It is found that the electron contribution ( $W_e^{\text{exp}}$ ) to the total static Stark widths is about 93% and the argon ions (Ar II, Ar III, ...) contribution about 7% (typically). It is found that the electron contribution



( $d_e^{\text{exp}}$ ) to the total static Stark shifts is about 91% and the argon ions (Ar II, Ar III, ...) contribution about 9% (typically). A clear influence of the quasi-static ion and ion dynamic effects on the investigated spectral line shapes is found. They play a much more important role than the what semi-classical theory provides, especially for these Ar I spectral lines, where the  $A^{\text{exp}}$  values are 60% higher than theoretical  $A^{\text{Griem}}$  values. The observed ion dynamic effect, at our plasma conditions, multiplies the quasi-static ion contribution by up to a factor 3 for widths and up to a factor 4 for shift for these Ar I lines. This can play an important role in the use of these lines for astrophysical plasma modeling or for diagnostics purposes.

Our broadening parameter ( $W_i^{\text{exp}}$ ,  $d_i^{\text{exp}}$ ) of the 751.465 nm, 763.511 nm and 772.376 nm represent the first set of measured values at electron temperatures higher than 12500 K. The comparison of our  $W_i^{\text{exp}}$ ,  $d_i^{\text{exp}}$ ,  $W_e^{\text{exp}}$ ,  $d_e^{\text{exp}}$  and  $A^{\text{exp}}$  values for these three Ar I spectral lines with the experimental data of other authors are not possible because of difference in plasma parameters in the first place because of difference in electron temperatures.

For the Ar I 696.543 nm spectral lines, the comparison among our values and the experimental data of other authors are much easier. In Refs. [18,22,30], electron temperatures are similar with ours so taking into account the approximate normalization factor  $W_i/N_e$  and  $d_i/N_e$ , we have found that our Stark width is 30% higher in average than theirs, and that the Stark shift is 15% higher in average than theirs. It is important to point out that all papers [10–30] for these seven Ar I spectral lines refer to the sum of the electron ( $W_e$ ) and ion ( $W_i$ ) contributions to the total Stark width ( $W_t$ ) and to the sum of the electron ( $d_e$ ) and ion ( $d_i$ ) contributions to the total Stark shift ( $d_t$ ) without estimating the contribution of electrons and ions separately. The only exception from this is Ref. [9] but, in that paper, ions are treated as quasi-static. Also, the plasma parameters in Ref. [9] are substantially different from ours. So, comparison between the results are difficult.

For three other Ar I spectral lines (727.294 nm, 706.722 nm and 738.398 nm) our Stark width ( $W_t^{\text{exp}}$ ) and Stark shift ( $d_t^{\text{exp}}$ ) represent the second set of measured values at electron temperatures higher than 14000 K. Direct comparison of our  $W_t^{\text{exp}}$  and  $d_t^{\text{exp}}$  values with other experimental data [28] is difficult because of the different plasma conditions in the experiments.

Our ion broadening parameters ( $A^{\text{exp}}$ ) are a factor of 2.5–3.5 larger (depending on discharge conditions) when we include the contribution of the ion–dynamical coefficient ( $D^{\text{exp}}$ ). Generally, for our experimental conditions with electron temperature approximately 16000 K: the electron contribution to the total static Stark width is about 90%; the electron contribution to the total static and dynamic Stark width is about 75%; the electron contribution to the total static Stark shift is about 80%; and the electron contribution to the dynamic Stark shift is about 50%.

#### 4. Conclusions

The  $W_e$ ,  $W_i$ ,  $d_e$  and  $d_i$  Ar I values presented here are the first data in the field, with the separate ion and electron contribu-

tions evaluated from the measured total Stark width and shift by using the line deconvolution procedure. We found clear influence of the quasi-static ion and ion–dynamical effects on the investigated spectral line shapes. They play a much more important role than the semi-classical theory predicts for the other lines from the same multiplets. The observed ion–dynamical effect augments the ion contribution to the line Stark width and shift by up to a factor of 3.5 over the ion–static component done, at the plasma conditions studied presently. This reveals the evident contribution, amounting to up to 9% and 20%, of the argon ions to the total line static width and shift. These findings are of importance in the use of Ar I line for astrophysical and laboratory plasma modeling, and for plasma diagnostics.

#### Acknowledgements

This work is a part of the project “Determination of atomic parameters on the basis of spectral line profiles” supported by the Ministry of Science and Environment Protection of the Republic of Serbia. V. Milosavljević and A. R. Ellingboe are grateful to Science Foundations Ireland under grand No.: 02/IN.1/I147 and European Union founding under EURATOM contract FU06-CT-2004-00068, for their support.

#### References

- [1] I.B. Gomushkin, A.Ya. Kazakov, N. Omenetto, B.W. Smith, J.D. Winefordner, Experimental verification of a radiative model of laser-induced plasma expanding into vacuum, *Spectrochim. Acta Part B* 60 (2005) 215–230.
- [2] P. Rodriguez-Gonzalez, J.M. Marchante-Gayon, J.I. Garcia Alonso, A. Sanz-Medel, Isotope dilution analysis for elemental speciation: a tutorial review, *Spectrochim. Acta Part B* 60 (2005) 151–207.
- [3] G. Cristoforetti, S. Legnaioli, V. Palleschi, A. Salvetti, E. Tognoni, Influence of ambient gas pressure on laser-induced breakdown spectroscopy technique in the parallel double-pulse configuration, *Spectrochim. Acta Part B* 59 (2004) 1907–1917.
- [4] P. Stavropoulos, C. Palagas, G.N. Angelopoulos, D.N. Papamantellos, S. Couris, Influence of ambient gas pressure on laser-induced breakdown spectroscopy technique in the parallel double-pulse configuration, *Spectrochim. Acta Part B* 59 (2004) 1885–1892.
- [5] J.A. Aguilera, C. Aragon, Calibration measurements in laser-induced breakdown spectroscopy using nanosecond and picosecond lasers, *Spectrochim. Acta Part B* 59 (2004) 1861–1876.
- [6] V. Milosavljević, V. Žigman, S. Djaniže, Stark width and shift of the neutral argon 425.9 nm spectral line, *Spectrochim. Acta Part B* 59 (2004) 1423–1429.
- [7] R. Álvarez, M.C. Quintero, A. Rodero, Radial distribution of electron density, gas temperature and air species in a torch kind helium plasma produced at atmospheric pressure, *Spectrochim. Acta Part B* 59 (2004) 709–721.
- [8] V. Hohreiter, J.E. Carranza, D.W. Hahn, Temporal analysis of laser-induced plasma properties as related to laser-induced breakdown spectroscopy, *Spectrochim. Acta Part B* 59 (2004) 327–333.
- [9] D. Schinköth, M. Kock, E. Schultz-Gulde, Experimental Stark broadening parameters for near-infrared Ar I and Kr I lines, *J. Quant. Spectrosc. Radiat. Transfer* 64 (2000) 635–643.
- [10] W.D. Jones, K. Musiol, L.W. Wiese, Stark widths and shifts for some Ar I 4s–4p transitions, in: K. Burnett (Ed.), *Spectral Line Shapes*, vol. 2, Walter de Gruyter, Berlin, 1983, p. 125.
- [11] A. Tonejc, Measurements of halfwidths of certain argon lines, *J. Quant. Spectrosc. Radiat. Transfer* 12 (1972) 1713–1715.

- [12] E. Sohns, M. Kock, Plasma diagnostics based on self-reversed lines: I. Model calculation and application to argon arc measurements in the near-infrared and vacuum ultraviolet regions, *J. Quant. Spectrosc. Radiat. Transfer* 47 (1992) 325–334.
- [13] S. Djeniže, Lj. Skuljan, R. Konjević, Experimental Stark shifts of several HeI and ArI spectral lines, *J. Quant. Spectrosc. Radiat. Transfer* 54 (1995) 581–587.
- [14] J. Chapelle, Sy. A. Cabonne, F. Cabanners, J. Blandin, Study of widths and transition probabilities of argon lines by means of a plasma jet, *J. Quant. Spectrosc. Radiat. Transfer* 8 (1968) 1201–1216; *C.R.H. Acad. Sci. Ser. B* 264 (1967) 853.
- [15] L. Bober, R.S. Tankin, Emission and absorption measurements on a strongly self-absorbed argon atom line, *J. Quant. Spectrosc. Radiat. Transfer* 9 (1969) 855–874.
- [16] J. Kusz, D. Mazur, Stark effect in some lines of neutral argon emitted from a ferroelectric plasma source, in: M. Zoppi (Ed.), *Spectral Line Shapes*, vol. 9, Lorenzo Ulivi, Firenze, 1996, p. 323.
- [17] M.S. Dimitrijević, L.J. Skuljan, S. Djeniže, Stark broadening of the Ar I spectral lines 763.51, 738.39 and 696.54 nm, *Phys. Scr.* 66 (2002) 77–81.
- [18] Y. Vitel, M. Skowronek, Nobel gas line profiles in dense plasmas: I. Argon, *J. Phys. B* 20 (1987) 6477–6491.
- [19] K.P. Nick, Thesis, University of Kiel (1982).
- [20] E. Iglesias, Y. Guimerans, R. Castell, D. Mandelbaum, A. Sanchez, Measurements of the Stark broadening of the neutral argon line 13406.6 Å in plasmas, *Acta Cient. Venez.* 34 (1983) 84–88.
- [21] N.I. Uzelac, Thesis, University of Belgrade, Yugoslavia, (1989).
- [22] A. Siyacoun, Thesis, University of Paris IV (1992).
- [23] S. Pellerin, K. Musiol, B. Pokrzywka, J. Chapelle, Stark width of  $4p'[1/2]-4s[3/2]'$  Ar I transition (696.543 nm), *J. Phys. B* 29 (1996) 3911–3924.
- [24] C.H. Popenoc, J.B. Schumacher Jr., Arc measurement of some argon transition probabilities, *J. Res. Natl. Bur. Stand., Sect. A* 69 (1965) 495.
- [25] D. Evans, R.S. Tankin, Measurement of emission and absorption of radiation by an argon plasma, *Phys. Fluids* 10 (1967) 1137–1144.
- [26] A. Tonejc, M. Aeinger, V. Vujović, Measurements of halfwidths of some argon lines in a wall-stabilized cascade, *J. Quant. Spectrosc. Radiat. Transfer* 12 (1972) 1305–1312.
- [27] V. Bakshi, J.R. Kearney, Measurement of Stark width of some Ar I transitions in a d.c. argon plasma jet at atmospheric pressure, *J. Quant. Spectrosc. Radiat. Transfer* 42 (1989) 405–413.
- [28] J.A. Aparicio, C. Pérez, J.A. del Val, M.A. Gigosos, M.I. delaRosa, S. Mar, Measurement of Stark broadening and shift parameters of several Ar I lines, *J. Phys. B* 31 (1998) 4909–4918.
- [29] J.C. Valognes, J.P. Bardet, Y. Vitel, New evaluation of Stark broadening of 6965 Å Ar I line including levels of like and unlike parentage, *J. Phys. B* 26 (1993) 4751–4768.
- [30] J.C. Valognes, J.P. Bardet, S.A. Flih, Y. Vitel, New contribution to study on Stark broadenings of 6965 of Ar(I) spectral line shapes in dense cold plasmas including levels of like and unlike parentage interactions, *J. Quant. Spectrosc. Radiat. Transfer* 87 (2004) 221–241.
- [31] H.R. Griem, *Plasma Spectroscopy*, Mc. Graw Hill Inc, New York, 1964.
- [32] H.R. Griem, *Spectral Line Broadening by Plasmas*, Acad. Press, New York, 1974.
- [33] V. Milosavljević, G. Poparić, Atomic spectral line free parameter deconvolution procedure, *Phys. Rev., E* 63 (2001) 036404–036407.
- [34] V. Milosavljević, G. Poparić, Reply to “Comment on ‘Atomic spectral line free-parameter deconvolution procedure’”, *Phys. Rev., E* 67 (2003) 058402-2.
- [35] A. Lesage, J.R. Fuhr, *Bibliography on Atomic Line Shapes and Shifts* (April 1992 through June 1999), Observatoire de Paris, 1999.
- [36] NIST – Atomic spectra data base lines (wavelength order) 2005–<http://physics.nist.gov>.
- [37] N. Konjević, A. Lesage, J.R. Fuhr, W.L. Wiese, Experimental Stark widths and shifts for spectral lines of neutral and ionized atoms (A critical review of selected data for the period 1989 through 2000, updated 2005 CD-ROM version), *J. Phys. Chem. Ref. Data* 31 (2002) 819–927.
- [38] V. Milosavljević, S. Djeniže, Ion contribution to the astrophysical important 388.86, 471.32 and 501.56 nm He I spectral lines broadening, *New Astron.* 7 (2002) 543–551.
- [39] V. Milosavljević, S. Djeniže, Ion contribution to the astrophysical important 447.15, 587.56 and 667.82 nm He I spectral lines broadening, *Astron. Astrophys.* 393 (2002) 721–726.
- [40] V. Milosavljević, S. Djeniže, Ion contribution to the Ne I spectral lines broadening, *Phys. Lett., A* 305 (2002) 70–74.
- [41] V. Milosavljević, S. Djeniže, The He I 706.52 nm line shape characteristics in the plasma diagnostics, *Eur. Phys. J. D* 23 (2003) 385–390.
- [42] V. Milosavljević, S. Djeniže, Ion contribution to the prominent Ne I, Ar I and Kr I spectral line broadening, *Astron. Astrophys.* 398 (2003) 1179–1184.
- [43] V. Milosavljević, S. Djeniže, Astrophysical plasma diagnostics through analysis of Ar I line shape characteristics, *Astron. Astrophys.* 405 (2003) 397–403.
- [44] V. Milosavljević, S. Djeniže, M.S. Dimitrijević, Experimental and calculated Stark widths within the Kr I spectrum, *Phys. Rev., E* 68 (2003) 016402–016408.
- [45] V. Milosavljević, M.S. Dimitrijević, S. Djeniže, Measured and calculated Stark parameters for several Ar I spectral lines, *High Temp. Mater. Process. (An international Journal)* 7 (2003) 525–533.
- [46] V. Milosavljević, S. Djeniže, M.S. Dimitrijević, Electron and ion contributions to the Ne I spectral line broadening, *J. Phys. B* 37 (2004) 2713–2724.
- [47] D.E. Kelleher, Stark broadening of visible neutral helium lines in a plasma, *J. Quant. Spectrosc. Radiat. Transfer* 25 (1981) 191–220.
- [48] V. Milosavljević, Stark widths of Spectral lines of neutral atoms of noble gases, PhD Thesis, University of Belgrade, Faculty of Physics, Belgrade, 2001.
- [49] S. Djeniže, A. Srećković, J. Labat, R. Konjević, L.Č. Popović, Stark broadening and shift of singly ionized zinc and cadmium spectral lines, *Phys. Rev., A* 44 (1991) 410–416.
- [50] S. Djeniže, V. Milosavljević, A. Srećković, Measured Stark widths and shifts of singly ionized oxygen spectral lines in lower multiplets, *J. Quant. Spectrosc. Radiat. Transfer* 59 (1998) 71–75.
- [51] S. Djeniže, V. Milosavljević, Dimitrijević, Stark shifts and transition probabilities in the Ne II spectrum, *Astron. Astrophys.* 382 (2002) 359–367.
- [52] V. Milosavljević, S. Djeniže, M.S. Dimitrijević, L.Č. Popović, Stark broadening parameters of the KrII and KrIII spectral lines, *Phys. Rev., E* 62 (2000) 4137–4145.
- [53] V. Milosavljević, M.S. Dimitrijević, S. Djeniže, Stark widths of the Ne II, Ne III and Ne IV spectral lines, *Astrophys. J., Suppl. Ser.* 135 (2001) 115–124.
- [54] S. Djeniže, S. Bukvić, Transition probabilities of several transitions in the Ar III and Ar IV spectra, *Astron. Astrophys.* 365 (2001) 252–257.