

2012-01-01

Cable Heating Effects due to Harmonic Distortion in Electrical Installations

Jonathan Blackledge

Technological University Dublin, jonathan.blackledge@tudublin.ie

Kevin O'Connell

Technological University Dublin, Kevin.OConnell@tudublin.ie

Martin Barrett

Technological University Dublin, martin.barrett@tudublin.ie

See next page for additional authors

Follow this and additional works at: <https://arrow.tudublin.ie/engscheleart>



Part of the [Engineering Commons](#)

Recommended Citation

Blackledge, J., O'Connell, K., Barrett, M., Sung, A.: Cable heating effects due to harmonic distortion in electrical installations. International Association of Engineers: ICEEE12, London, 2012

This Conference Paper is brought to you for free and open access by the School of Electrical and Electronic Engineering at ARROW@TU Dublin. It has been accepted for inclusion in Conference papers by an authorized administrator of ARROW@TU Dublin. For more information, please contact arrow.admin@tudublin.ie, aisling.coyne@tudublin.ie, vera.kilshaw@tudublin.ie.

Authors

Jonathan Blackledge, Kevin O'Connell, Martin Barrett, and Anthony Sung

Cable Heating Effects due to Harmonic Distortion in Electrical Installations

Kevin O'Connell, Martin Barrett, Jonathan Blackledge and Anthony Sung

Abstract—The increasing use of non-linear loads in electrical installations has exacerbated the problems of harmonic distortion in industrial and commercial electrical systems. In the UK the current practice to determine the cable size for an electric circuit is to use BS7671. However, previously the 16th edition IEE Wiring Regulations only dealt with situations where cables attain the conductor temperature generated by sinusoidal currents at the fundamental power frequency. This paper outlines the methods available to determine the minimum size of line conductors for protection against overload currents, taking into account the harmonic content of the load current, and explains the harmonic rating factor Cf introduced in 2008 for cables that are under significant harmonic influences. Since the effect of harmonic currents is to increase the joule losses in a cable, the ampacity of the cable will need to be corrected to ensure the maximum conductor operating temperature is not exceeded. An experiment on how cable temperature can be measured under harmonic influence is described, and several sets of measurements taken on a typical cable are analysed. The paper concludes that direct usage of the BS7671 rating factor for harmonics appears to be rather conservative and could lead to over-sizing of the line conductors for three-phase circuits, but is deemed beneficial in the long run.

Index Terms—Non-linear loads, harmonics distortion, harmonic contents, triplen harmonics, heat emitter, ampacity, cables, correction factors, derating factor, BS7671, IEC, NEC, skin effect, proximity effect.

I. INTRODUCTION

HARMONIC distortion in low voltage electrical installations is now a common occurrence in the built environment. It is caused by non-linear loads and historically was only associated with industrial power systems that used large static power converters. The increased usage of information technology equipment and low energy devices in buildings over the past twenty years, which result in non-linear electrical loads has introduced a high level of harmonic distortion into the LV electrical system. As a result, it has become necessary to establish criteria for limiting problems from system quality degradation. E. W. Fuchs et al [1] reported that the present versions of IEEE519-1992 [2] and IEC61000-3-2 [3] harmonic standards are too restrictive for low-frequency voltage and current harmonics, as they apply to residential power systems.

II. BS7671 METHOD FOR DETERMINING CABLE SIZE FOR PROTECTION AGAINST OVERLOAD

In the UK the general method used to determine the size of a line conductor is based on the method described in BS7671 (17th edition IEE Wiring Regulations) [4].

Manuscript submitted on 1 March, 2012.

K. O'Connell, School of Electrical Engineering Systems, Dublin Institute of Technology

M. Barrett, School of Electrical Engineering Systems, Dublin Institute of Technology

J. Blackledge, Stokes Professor, Dublin Institute of Technology

A. Sung, Director of Research of N. G. Bailey Ltd

In appendix 4 of BS7671, tables of ampacity and the associated impedance drop of common types of cables can be found. However, the ampacity published are based on the assumption that there is no harmonics present in the cabling system. Clearly the three-phase four wire ampacity rating column in the tables does not count the neutral conductor as a current carrying conductor hence it has no heat emission.

The basic method to determine the size of a line conductor for protection against overload is given in BS7671 Appendix 4, Section 5 and is as follows:

$$I_Z = I_t C_a C_g C_i C_c \geq I_n \geq I_b \quad (1)$$

where I_Z is the continuous service ampacity in amperes of a cable having taken all the applicable rating factors into account under defined installation conditions; I_t is the tabulated ampacity in amperes of a cable (BS7671 Table 4A2, gives a schedule of appropriate ampacity tables included in BS7671); C_a is the rating factor for ambient temperature and is given in BS7671 Tables 4B1 and 4B2; C_g is the rating factor for conductors that are grouped in defined installation arrangements (given in BS7671 Tables 4C1, 4C2, 4C3, 4C4 and 4C5); C_i is the rating factor for conductors embedded within thermal insulation, (given in BS7671 Part 5 Regulation 523.7 and Table 52.2); C_c is the rating factor for the type of protective device or under defined installation conditions (given in BS7671 appendix 4, section 5.1 and Tables 4B3); I_n is the nominal rated current or current setting in amperes of the over-current device (its value can be selected from either BS7671 Appendix 3 or device manufacturers technical data literatures); I_b is the design current in amperes of the circuit under normal steady state operating conditions and calculated using the declared nominal voltage level.

For single phase loads and for single phase motors

$$I_b = \frac{P}{U_0 \cos \phi} \quad \text{and} \quad I_b = \frac{P_m}{U_0 \cos \phi \eta}$$

respectively, where P is the total active power of the load in W, P_m is the total mechanical power of the load in W, U_0 is the nominal a.c. rms line to an earthed neutral voltage in V, $\cos \phi$ is the displacement power factor without harmonic contents and η is the mechanical efficiency of the motor. Similarly for three phase loads and motors,

$$I_b = \frac{P}{\sqrt{3}U \cos \phi} \quad \text{and} \quad I_b = \frac{P_m}{\sqrt{3}U \cos \phi \eta}$$

respectively, where U is the line-to-line voltage in V, and $\sqrt{3}U_0 = U$.

Depending on the actual installation circuit arrangement, not all rating factors C_a , C_g , C_i or C_c need to be applied. For example, if the circuit is not buried and an approved type of circuit breaker (BS EN 60898) is being used, which

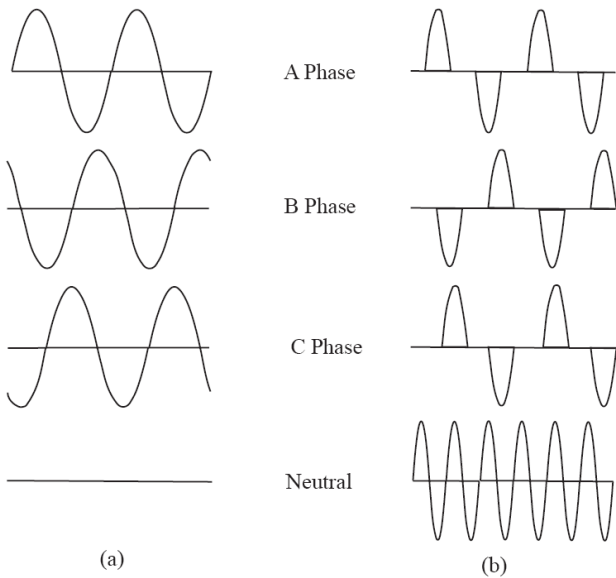

Fig. 1. Current Waveforms of (a) linear load vs (b) non-linear load for a sinusoidal ac supply at fundamental frequency of 50 or 60 Hz.

is usually the case, C_c should be omitted from the equation (1). Further, if the cable is not totally surrounded by thermal insulations equation (1) can be reduced to

$$I_Z = I_t C_a C_g \geq I_n \geq I_b$$

The ampacity tables found in BS7671 and other international standards such as the ET 101 [5] and IEC 60364 [6] generally assume a balanced three-phase linear load when the current in the neutral conductor of a three-phase four-wire circuit will be negligible.

Most commercial and industrial establishments tend to employ balanced three-phase four-wire distribution systems with a reduced size neutral conductor. However, with the proliferation of non-linear loads in this type of electrical design, the triplen (multiples of 3rd order harmonics) harmonic current from each phase sums in the neutral. P. Cook et. al. [7] report that neutral currents can be higher than the phase currents where high harmonic distortion exists. The line and neutral currents that were taken by two separate but balanced three-phase four-wire linear loads and non-linear loads are shown in Figure 1(a) and Figure 1(b), respectively.

In Figure 1(a), with a linear load, all three phases draw perfect sinusoidal current waves. Since they are balanced they cancel out in the neutral, thus the neutral conductor carries negligible current. Although in practice, even where load currents are at the standard fundamental power frequency of 50Hz or 60Hz there is rarely zero current in the neutral. Any value of current that exists in the neutral simply reflects an out-of-balance in the three-phase load. Assuming that no phase is overloaded and the cable was sized using the basic method outlined above. The effect of an out of balance three phase load causing the neutral conductor to become a heat emitter should not cause any overheating to the group of three-phase four-wire cable. However, when harmonics are present as shown in Figure 1(b), the line current in the three phases are no longer balanced sine waves and if they are in triplen order (i.e. $3n$), they will be additive in the neutral. Now the neutral conductor becomes a fourth and additional

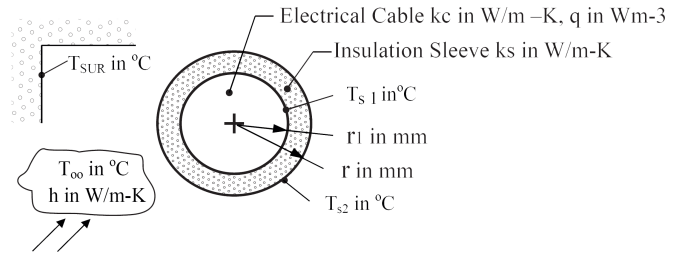

Fig. 2. Schematic for an Electric Cable.

current carrying conductor. As a result, it is an additional heat-emitting source in the group of four conductors.

In view of the fact that the neutral conductor is now a current carrying conductor, hence a heat emitter, steps need to be taken to take account of the extra heat that is produced by the neutral conductor in a three phase circuit. The update published by the IEE (now the IET) [13] states that for every 8°C increase above the maximum core conductor continuous operating temperature the life of the cable will be halved (e.g. 25 years reduced to 12.5 years). A method is thus required to size the cable accordingly to dissipate the extra heat that is being generated within a group of three-phase four-wire conductors to ensure that the group of four conductors does not overheat

III. HEAT TRANSFER MECHANISMS IN ELECTRIC CABLES

A comprehensive review and research on the heat transfer mechanisms of electrical cables, which focused mainly on overhead line cables is given in [8]. In general, the heat balance of any cable can be considered by the law of conservation of energy and on a rate basis, we have

$$\frac{\partial}{\partial t} q_{in} + \frac{\partial}{\partial t} q_{gen} = \frac{\partial}{\partial t} q_{stored} + \frac{\partial}{\partial t} q_{out}$$

where $\partial q/\partial t$ is the rate of heat energy per unit volume, q_{in} is the heat input, q_{gen} is heat generated internally, q_{stored} is heat stored by the medium and q_{out} is heat loss to the external environment.

In [8] it is shown that the heat transfer mechanisms associated with an electric cable immersed in air can be approximated using the following assumptions: (i) using cylindrical coordinates, it is a one-dimensional radial conduction, convection and radiation system; (ii) it has uniform volumetric heat generation; (iii) the thermal contact resistance between the conductor material and electrical insulation material is negligible; (iv) the electrical and thermal properties of the conductor and insulation materials are constant (i.e. homogeneous); (v) the surroundings are large compared to the cable; (vi) the analysis is for steady state conditions.

An energy balance rate basis analytic technique can be applied to an electrical cable (see Figure 2) to evaluate the surface temperature of the conductor or the cable. For the control surface (see Figure 3) placed around the inner and outer surfaces of the insulation material:

$$E'_{in} - E'_{out} = 0$$

since *energy in* is taken to be equal to *energy out*,

$$E'_{in} = E'_{out} = q'_r = q'_r \pi r_1^2 \quad (2)$$

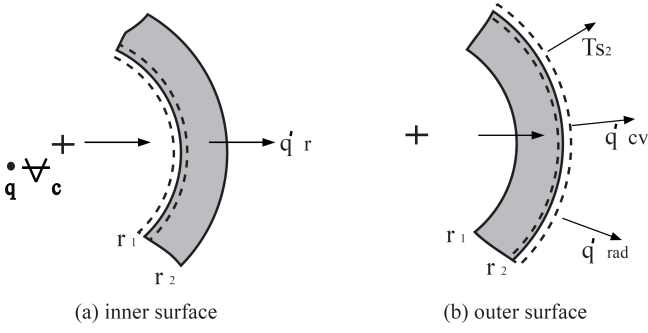

Fig. 3. Energy exchanged at the inner and outer surfaces of the electrical insulation of a conductor.

$$q'_r - q'_{cv} - q'_{rad} = 0 \quad (3)$$

hence, from equation (2) and (3), at the outer surface

$$\pi q'_r r_1^2 - h(2\pi r_2)(T_{s,2} - T_\infty - \epsilon(2\pi r_2)\sigma(T_{s,2}^4 - T_{sur}^4)) = 0$$

This general equation can be used to determine the surface temperature $T_{s,2}$ of a cable in terms of q'_r , r_1 , r_2 , h , T and ϵ where h is the convection coefficient in W/m^2K and ϵ is the dimensionless emissivity of the cable surface.

IV. INDUSTRY METHODS AVAILABLE FOR DETERMINING THE SIZE OF A CABLE UNDER HARMONIC DISTORTION

A. The Neher-McGrath Method

In 1957 Neher and McGrath [9] derived a set of Neher and McGrath (NM) cable rating equations to predict the resulting ampacity of a group of four single core cables. They are a more complex version of the Fourier heat transfer equations. There are many variables in the 66 equations used to account for the number of conductors, number and size of adjacent conduits, number and size of adjacent duct banks, coefficient of surface emissivity, number of cables, axial spacing between cables, extraneous heat sources, and wind velocity. All these factors and more, effect the calculation of ampacity. Two of the factors affecting the final ampacity value of a cable under harmonic conditions are the 'skin and proximity' effects. The NM equation is given by

$$I = \sqrt{\frac{T_c - (T_a - \Delta T_d)}{r_{dc}(1 + Y_c)r'_{ca}}} \quad (4)$$

where I is the conductor current in kA, T_c is the conductor temperature in degree $^{\circ}C$, T_a is the ambient temperature in degree $^{\circ}C$, ΔT_d is the temperature difference due to dielectric loss in degree $^{\circ}C$, r_{dc} is the direct current resistance of the conductors in Ω at the conductors operating temperature per unit length, r'_{ca} is the effective resistance between the conductor and ambient for a conductor loss in Ω at the conductors operating temperature per unit length. The parameter Y_c is the increment of ac/dc ratio in p.u. due to losses originating in the conductor, having components Y_{cs} (the skin effect) and Y_{cp} (the proximity effect) where

$$Y_c = 1 + Y_{cs} + Y_{cp}$$

$$Y_{cs} = 0.875 \sqrt{\frac{fk_s}{r_{dc}}}$$

$$Y_{cp} = x_p \left(\frac{D_c}{S}\right)^2 \left[\left(\frac{1.18}{x_p + 0.27}\right) + 0.312 \left(\frac{D_c}{S}\right)^2 \right]$$

and

$$x_p = \frac{6.80}{\sqrt{r_{dc}/k_p}} \text{ at } 60\text{Hz}$$

where f is the frequency in Hz, D_c is the conductors outer diameter (in inches), S is the axial spacing between cables (in inches) and k_s and k_p are the skin and proximity effect factor respectively (with recommended values of 60Hz [9]).

The NM method does not cater for the inclusion of a range of harmonic components in the generalised equation (4). The NM equation is very similar to the IEC60287 method [15] as they are both based on the same principle.

B. The Meliopoulos and Martin Method

The Meliopoulos and Martin method [10] provides an extension of the Neher-McGrath equation using power losses in the cable under harmonic conditions to derive a derating factor for cables given in the NEC [11]. For single phase circuits

$$\kappa = \sqrt{\frac{\alpha_1^2 I_B^2 r_{ac}(1)}{P_{loss}}}$$

and for three phase circuits

$$\kappa = \sqrt{\frac{\alpha_1^2 I_B^2 [r_{ac,A}(1) + r_{ac,B}(1) + r_{ac,C}(1)]}{P_{loss}}}$$

where κ is the desired harmonic derating factor $r_{ac,A}(1)$, $r_{ac,B}(1)$ and $r_{ac,C}(1)$ are the ac resistance of phase A, B and C conductors at fundamental frequency, P_{loss} is the total ohmic losses of the cable including harmonic effects, I_B is the base RMS value of the design current and α_1 is the p.u. value of the fundamental with respect to the base I_B . For harmonics at a frequency of $h * f_{fundamental}$, additional values can be found by the equations for $x_s(h)$, $x_{sp}(h)$ and $x_{cp}(h)$ as given below:

$$x_s(h) = \left(\frac{ka}{2} \frac{M_0(ka)}{M_1(ka)} \sin[\theta_1(ka) - \theta_0(ka) - \pi/4]\right) - 1 \quad (5)$$

where $k = \sqrt{2\pi f h \mu \sigma}$, a is the conductor radius in metres, f is the fundamental power frequency in Hz, μ is the relative permittivity of the conductor, σ is the conductivity (of the conductor), h is the harmonic order and $M_0(ka)$, $M_1(ka)$, $\theta_0(ka)$ and $\theta_1(ka)$ are Bessel functions obtained from [10].

$$x_{sp}(h) = F(x_p) \left(\frac{D_c}{S}\right)^2 \times \left[\left(\frac{1.18}{F(x_p) + 0.27}\right) + 0.312 \sqrt{h} \left(\frac{D_c}{S}\right)^2 \right] \quad (6)$$

where $x_p = k \sqrt{k_p / (\pi \sigma r_{dc})}$ at the h^{th} harmonic and k_p is the empirical factor at fundamental power frequency from [9].

$$F(x_p) = \left(\frac{x_p}{2} \frac{M_0(x_p)}{M_1(x_p)} \sin[\theta_1(x_p) - \theta_0(x_p) - \pi/4]\right) - 1 \quad (7)$$

The contribution to the increase of conductor ac resistance due to proximity to a steel pipe or magnetic conduit is given by the following expressions: For a trefoil arrangement

$$x_{cp}(h) = \alpha\sqrt{n} \left(\frac{0.89S - 0.115D_p}{r_{dc}} \right) \times 0.3048 \times 10^6 \quad (8)$$

and for a flat cradled arrangement

$$x_{cp}(h) = \alpha\sqrt{n} \left(\frac{0.89S - 0.175D_p}{r_{dc}} \right) \times 0.3048 \times 10^6 \quad (9)$$

where $\alpha=1.7$ for a steel pipe and 0.8 for an iron conduit, D_p is the inside diameter of the pipe or conduit in metres and

$$r_{ac}(h) = r_{dc}[1 + x_s(h) + x_{sp}(h) + x_{cp}(h)] \quad (10)$$

Two examples were given by Meliopoulos and Martin [10] to illustrate the full computation procedures to use the above equations. It will not be repeated here and readers who wish to consider these equations should refer to the original paper [10].

However, if the designer finds that the Meliopoulos and Martin approximation derates the cable leading to an inaccuracy or when significant zero sequence harmonic currents are present in the neutral, then the Neher-McGrath equation should be used to re-rate the cable.

C. The AH Generalised Ampacity Model

Hiranandani [12] develops a simple general equation that can be used to evaluate separate harmonic derating factors for line and neutral conductors. The AH method for calculating a cables ampacity in the presence of harmonics for NEC cables can be summarized as follows:

1. Determine the harmonic signature of the line and neutral conductors by either calculation or measurement. The Harmonic Signature (HS) is then determined by the equation

$$HS = \left(I_1, \alpha_y = \frac{I_y}{I_1}, \alpha_{y+1} = \frac{I_{y+1}}{I_1}, \alpha_{y+2} = \frac{I_{y+2}}{I_1}, \dots \right) \quad (11)$$

where $y = 2$. For example, a three-phase distribution circuit with a THD=41.9% has a phase current $I_{rms} = 99.12A$; $I_{50Hz} = I_1 = 90A$; $I_{150Hz} = I_3 = 35A$; $I_{250Hz} = I_5 = 20A$; $I_{350Hz} = I_7 = 10A$ and a neutral current $I_{150Hz} = I_3 = 3 \times 35 = 105A$. Hence from equation (11), the harmonic signatures are: Line HS=(90, $\alpha_3=0.39$, $\alpha_5=0.222$, $\alpha_7=0.111$) and Neutral HS= (90, $\alpha_3=1.17$).

2. Determine the total ac resistance (r_{ac}) of the line and neutral conductors including skin effect and proximity effect using equation (10).

where h is the order of the harmonic, r_{dc} is the dc resistance of the conductor in Ω at the conductors operating temperature per unit length, x_s is the contribution factor to ac resistance due to skin effect, x_{sp} is the contribution factor to ac resistance due to proximity effects of neighbouring conductors, x_{cp} is the contribution factor to ac resistance due to proximity effect of a metallic pipe or conduit, $r_{ac}(h)$ is the ac resistance, and $x_s(h)$, $x_{sp}(h)$ and $x_{cp}(h)$ are skin effect and proximity effect factors calculated for each harmonic order h as given in [10] from equations (5)-(9)

TABLE I
RATING FACTORS FOR TRIPLE HARMONIC CURRENTS IN FOUR- AND FIVE-CORE CABLES (SOURCE: BS7671). *THE 3RD HARMONIC CONTENT IS EXPRESSED IN TERMS OF THE TOTAL HARMONIC DISTORTION.

3rd harmonic content of line current* (%)	Rating Factor	Rating Factor
	Size selection based on the line current	Size selection based on the neutral current
0-15	1.0	-
15-33	0.86	-
33-45	-	0.86
>45	-	1.0

3. The derating factor for line and neutral conductors in the presence of harmonics can be evaluated using equation (12):

$$HDF = \left(1 + \sum_{h=2}^n \alpha_h^2 \beta_h \right)^{-\frac{1}{2}} \quad (12)$$

where α_h is the harmonic distribution factor per unit harmonic content due to each harmonic with respect to base load current (i.e. $\alpha_h = I_h/I_1$) and β_h is the normalized harmonic ac resistance factor, i.e. the ratio of conductor resistance at n^{th} harmonic frequency to resistance at fundamental power frequency - $\beta_h = r_{ac}(h)/r_{ac}(1)$.

Similar to the approach proposed by Meliopoulos and Martin, it is necessary to assume a certain cable size and derate it by the factor HDF accordingly. Hiranandani presents a worked example similar to the one given by Meliopoulos and Martin but giving a different set of results for the derived derating factor.

D. The BS7671 Appendix 11 Method

In 2004 the International Electrotechnical Commission (IEC) published a set of harmonic rating factors so that allowance can be made for 3rd harmonic currents in 4 and 5 core cables, where all the cores have the same conductor size. It is now included in BS7671 Appendix 11 as informative guidance - see Table I.

Cook and Coate [7] explained the guidance given by the IEC such that if the third harmonic content of the current in each phase is between 33% and 45%, i.e. the neutral current is greater than the fundamental phase current, then selection of the conductor size should be based on the current in the neutral conductor divided by the given factor. If the harmonic content is greater than 45% then the size of the line conductor chosen is based on the neutral conductor current. In this case the line conductors will be larger than that required to carry the line current and this 'spare' capacity allows the factor of 0.86 to be omitted.

Three examples are given in BS7671 Appendix 11 illustrating how to apply the rating factor in practice. It will not be repeated here and readers who wish to consider the rating factor should refer BS7671.

V. EXPERIMENTAL DETERMINATION

An experiment was set up to inject discrete harmonic currents into a 185 sq.mm solid core aluminum cable. A

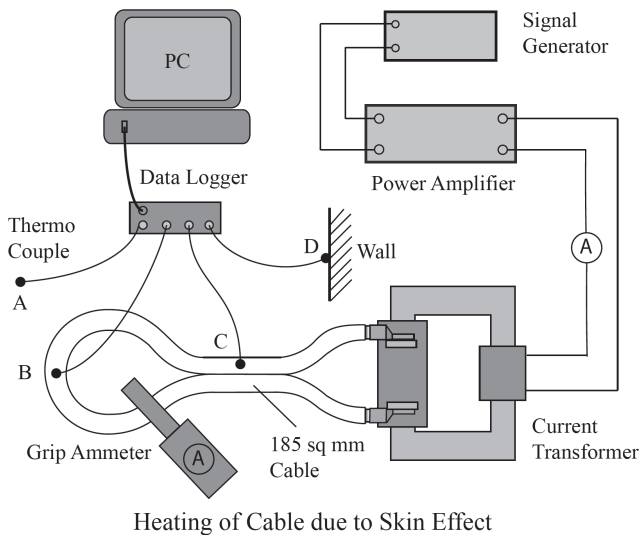

Fig. 4. Experimental setup for measuring harmonic heating effects in cables.

schematic diagram of the equipment used is as shown in Figure 4. A signal generator was connected to the input of a 400W power amplifier, which, in turn, was connected to a current transformer as shown. The cable under test was connected to the primary of a current transformer. This arrangement allowed the full rated current of 400A to be injected into the cable at discrete frequencies, which could be set by the signal generator and measured by the grip ammeter. Thermo couples embedded in the cable at points B and C (see Figure 4 accurately measure the conductor temperature. Thermo couple A measures the ambient air temperature. The cable was shaped as shown so that thermo couple B would indicate the temperature of a single conductor suspended in free air. Thermo couple C would indicate the temperature of conductors in close proximity running parallel to each other also suspended in free air. The thermo couples B and C can thus measure the additional heating effect due to the skin and proximity effects respectively as the cable is run at full load at frequencies of n , (50Hz), $3n$, $5n$, $7n$... up to $20n$.

Initially, the cable was fully loaded at 50 Hz and the result compared with the value of 70°C quoted in BS 7671. Adjustments to the readings were made to compensate for the actual ambient temperature in the laboratory at the time of the test. This test validated the accuracy of the measuring system used as shown in the graph in Figure 5. Further tests were carried out by injecting the full rated current value (400 A) at various harmonic frequencies. and the results are shown in Figure 6. It can be seen that the conductor temperature at 50Hz is approximately 70°C , which agrees with BS7671. However as the frequency is increased whilst maintaining the current at 400A full rated value, it can be seen that the temperature of the conductor increases significantly. The temperature of the parallel conductors has increased by a larger amount reflecting the combined skin and proximity effects.

Load currents that have significant harmonic distortion such as those supplying personal computers (see Figure 7) will therefore experience additional heating due to both the skin and proximity effects. Arising from this, cables will operate at a higher temperature than would be the case

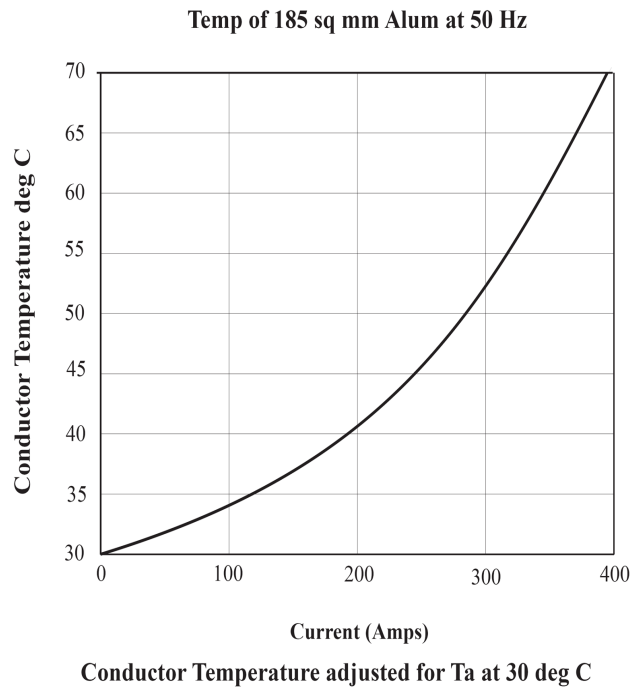

Fig. 5. Temperature rise of cable under harmonic influences.

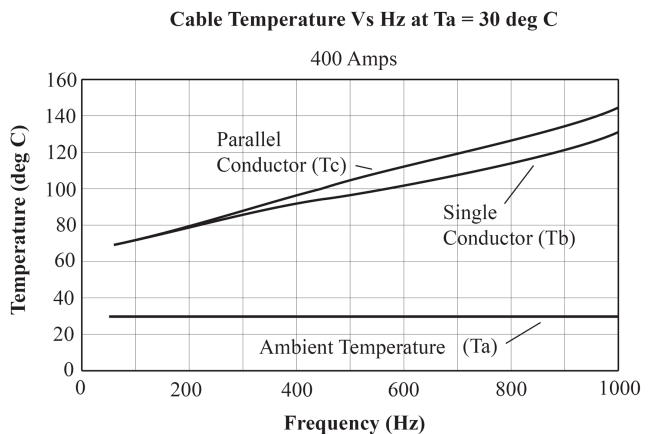

Fig. 6. Temperature Vs Harmonics for various cable configurations.

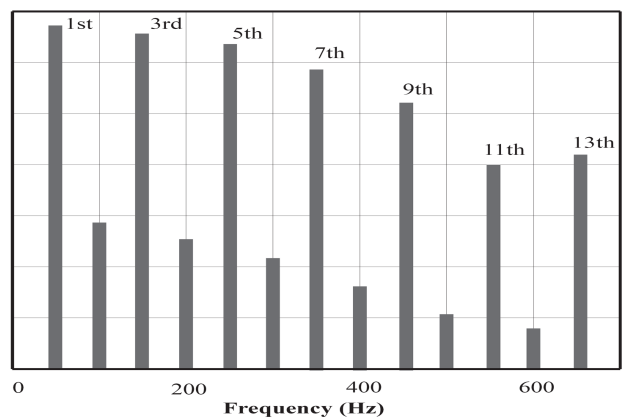

Fig. 7. Spectral analysis of current.

without harmonic distortion. If one can predict the degree of harmonic distortion in the load current heating then it is possible to determine the degree of additional heating that will occur

and apply a suitable de-rating correction factor.

The experimental data collected and analysed in the above experiment proves that there are indeed significant heating effects in a conductor carrying harmonic currents as predicted by Meliopoulos and Martin [10] and in the AH Generalised Ampacity Model by Hiranandani [12]. Those effects must be taken into consideration and it is likely that the oversizing of conductors by the BS7671 Appendix 11 method can adequately cover the excess heating caused by the harmonic content of the currents.

VI. DISCUSSION

There are a number of ways to reduce and combat the detrimental effects of high levels of harmonic distortion in an electrical installation, e.g. by the application of filters etc. Active filters are devices which actively inject opposite harmonics into a system to cancel out the harmonics created by the non-linear loads. Passive filters trap or resist the flow of harmonics through them. They do this through various capacitors or reactors. Harmonics rated transformers known as K factor transformers are specifically designed in order to cope with the excess heating problem caused by the presence of high level circulating harmonic currents. The thermal and neutral connections are sometimes being sized at around 200% of the size required in order to accommodate the harmonic loads [3]. Most of the remedial systems that are put into place do work, but are usually quite costly especially if they are not initially included at the design stage. Also, filters and transformers may require maintenance or could suffer failures if not designed and installed properly. The dire consequence of which will render the system unprotected and the harmonics present may cause damage in this time period, especially if there is a failure in the equipment as there may be a certain length of time until the fault is found and rectified.

Reducing the temperature of the conductors is one of the most important cabling design aspects in an electrical installation. It has been clearly demonstrated in this paper, that in order to maintain the operating temperature of the cable within the specified maximum tolerable temperature, an increase in the cross-sectional area of the conductor is required. With a larger cross-sectional area, even if the filter or the transformer is faulty, the cables will be sized to cope with the extra currents, reducing the damage that can be caused. Another fact to consider is that these calculations have been carried out on the assumption that the neutral conductor is carrying 100% third harmonic load. However, at certain times of the day, if the equipment that causes harmonic distortion is not operating, the harmonic load will be reduced and as a result of this, the voltage drop will reduce further, making the circuit much more energy efficient.

There are several advantages to increasing the cable size as a result of harmonic derating, in most cases, only up to the next size. They include:

- harmonic loads are accounted for and even if preventative measures (e.g. filters, transformers) fail, the cables are adequately sized to carry the load;
- temperature rise of the cable is reduced, reducing losses, maintenance and running costs (increasing the life expectancy of the cable);

- larger cross-sectional areas can reduce the voltage drop along the circuit, proving more efficient by delivering close to the declared voltage to the current using equipment.

VII. CONCLUSION

Harmonic distortion in electrical installations of tomorrow is likely to get worse as the rise in use of low energy electrical equipment in the built environment increases. Steps need to be taken by electrical designers and installers to minimise its detrimental influence on the interconnecting cables, busbars, energy sources and neighbouring equipment. With the newly published BS7671 (17th edition IEE Wiring Regulations) in 2008, at long last designers and installers now have a set of harmonic rating factors which can be used in the initial design calculations to determine reasonably accurately the size of cables to allow for conditions when harmonic distortion is present in a system. Alternatively, they can use the other calculation methods given in this paper to calculate the heating effect of harmonic currents from first principles. Often the BS7671 method may result in an oversized cable, however, it was discussed earlier that this process is only beneficial as it can reduce the operating temperature of the cable and as a result the voltage drop in the cable is also reduced, thereby decreasing losses and increasing transmission efficiency.

ACKNOWLEDGMENT

The authors would like to thank Dublin Institute of Technology, the Science Foundation Ireland and the Dublin Energy Laboratory for their continuing support.

REFERENCES

- [1] E. F. Fuchs, D. J. Roesler, and M. A. S. Masoum, "Are Harmonic Recommendations According to IEEE and IEC Too Restrictive?", *IEEE Transactions on Power Delivery*, Issue: 99, 2004.
- [2] IEEE, *IEEE Recommended Practices and Requirements for Harmonic Control*, in *Electric Power Systems*, IEEE-519, 1992.
- [3] IEC, *Consolidated Edition. Electromagnetic Compatibility (EMC)-Part 3-2 Limits for Harmonic Current Emissions*, IEC 61000-3-2 (2001-10).
- [4] IEE/BSI, BS 7671:2008, *Requirements For Electrical Installations*, IEE Wiring Regulations 17th Edition, 2008.
- [5] ETCL, *ET101: 2004 - National Rules for Electrical Installations*, Fourth Edition, 2004, Electro-Technical Council of Ireland.
- [6] IEC, *IEC60364: 2002-06 - Electrical installations of buildings*, 2nd Edition, Geneva, Switzerland.
- [7] P. Cook and M. Coates, "Double Neutrals, The Answer To Triple Harmonics?", *International Seminar*, Santiago, CHILE 26-28 April 2000.
- [8] V. T. Morgan, *Thermal behaviour of electrical conductors*, Wiley, (ISBN: 0863801196), 1991.
- [9] J. H. Neher and M. H. McGrath, "The Calculation of the Temperature Rise and Load Capability of Cable Systems" Vol. 76, pp. 752-772, *AIEE*, March 1957.
- [10] A. P. S. Meliopoulos, M. A. Martin, "Calculation of secondary cable losses and ampacity in the presence of harmonics", *IEEE Transactions on Power Delivery*, Vol. 7, No. 2, April, 1992.
- [11] NFPA, *National Electrical Code 2008*, NFPA, 2008.
- [12] A. Hiranandani, "Calculation of Conductor Temperatures and Ampacities of Cable Systems using a Generalised FDM Method", *IEEE Transactions on Power delivery*, Vol. 6, No. 1, Jan. 1991.
- [13] P. Cook, (Update published by the IEE - now the IET), *Commentary on IEE Wiring Regulations 16th edition BS7671:2001* Peregrinus, ISBN: 0 85296 237 1, April 2004.
- [14] F. P. Incropera and D. P. Dewitt, *Introduction to Heat Transfer*, Wiley, (4th Edition. ISBN: 0-471-38649-9
- [15] IEC 60287: *Electric cables - Calculation of the current rating*, IEC Central Office, GENEVA 20, Switzerland.