

7-1-1965

The Irish Plumbing and Heating Engineer, July 1965 (complete issue)

Follow this and additional works at: <https://arrow.tudublin.ie/bsn>

 Part of the [Civil Engineering Commons](#), [Construction Engineering Commons](#), and the [Construction Engineering and Management Commons](#)

Recommended Citation

(1965) "The Irish Plumbing and Heating Engineer, July 1965 (complete issue)," *Building Services Engineering*: Vol. 5: Iss. 4, Article 1.

doi:10.21427/D7TX33

Available at: <https://arrow.tudublin.ie/bsn/vol5/iss4/1>

This Article is brought to you for free and open access by the Journals at ARROW@TU Dublin. It has been accepted for inclusion in Building Services Engineering by an authorized editor of ARROW@TU Dublin. For more information, please contact arrow.admin@tudublin.ie, aisling.coyne@tudublin.ie, vera.kilshaw@tudublin.ie.

ENGINEER



THE HEART OF A WARM HEARTED HOUSE



THE NEW UNIDARE WALLFLAME BOILER



THE NEW WALLFLAME BOILER—WITH BUILT IN STABILISER
Reliable, Automatic, Elegant—designed to give the full benefit of
luxurious oil fired central heating . . . and constant hot water too.
The Unidare Wallflame Boiler is the first Irish made wallflame
boiler . . .

Manufactured by

UNIDARE LIMITED

Unidare Works, Finglas, Dublin 11
Tel. 71801 (15 lines)

For the future BUY IRISH QUALITY GOODS

JULY 1965

Published by ARROW@TU Dublin, 1965
Vol. 3 No. 4

SPECIAL MONTHLY SUPPLEMENTS: NORTHERN IRELAND MONTHLY
REVIEW—INDUSTRIAL HEATING AND VENTILATING IN IRELAND

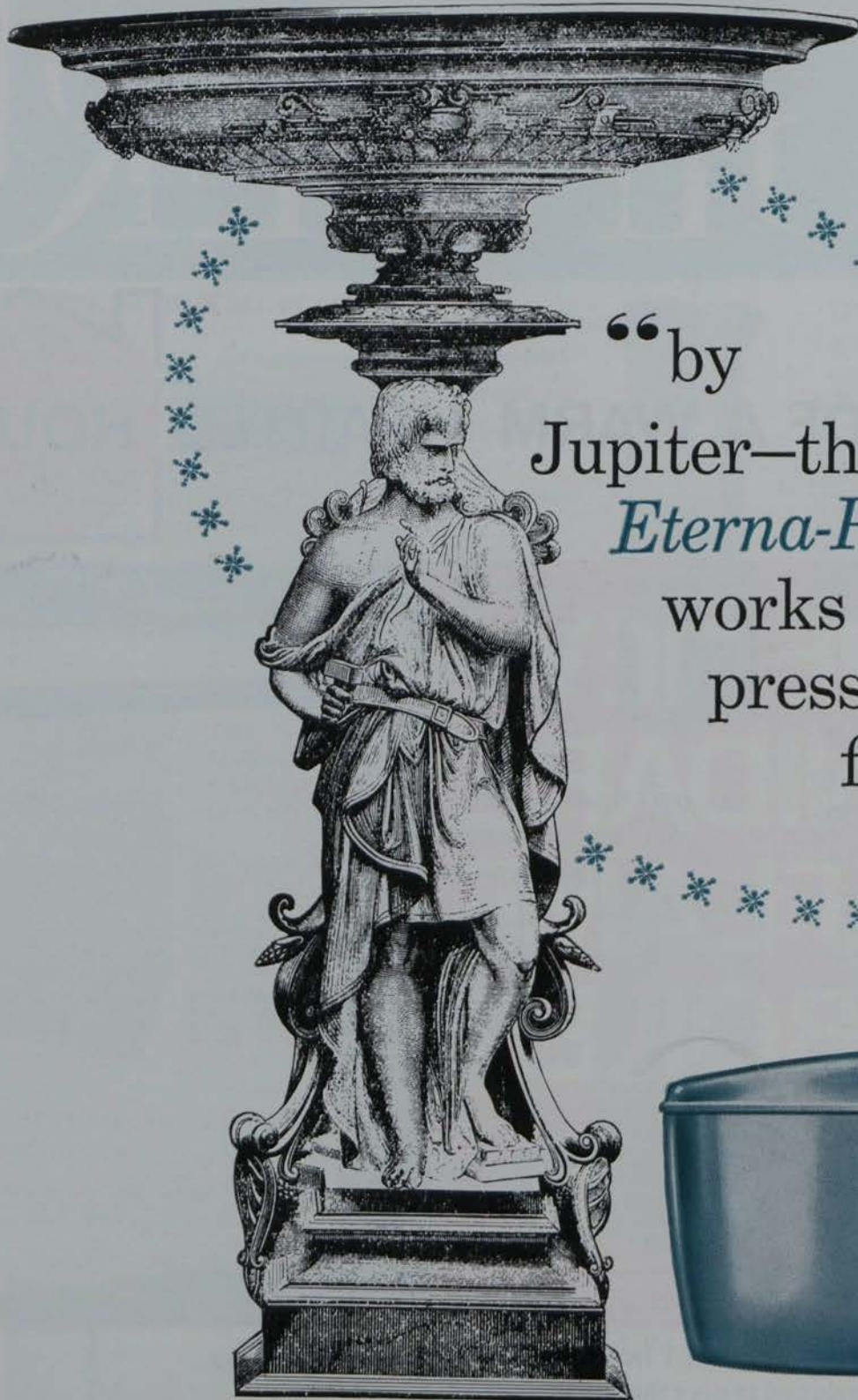

“by
Jupiter—the
Eterna-Presto
works at the
press of a
finger”



Presto—a variation on the popular Eterna. Presto—the cistern with the effortless press-down flushing device. Reliable. Neat. In brilliant, durable plastic. Low level Presto with the whisper-quiet operation of every Fordham.

Quality costs less at **Fordham**

Write for further details and illustrated brochure



418 PATTERN RATCHET DIESTOCK

Better threads, easier cutting, and quick and simple die and guide changing are the attractive features of this Chatwin product. The 418 Pattern Ratchet Diestock and die must satisfy the need for a tool which makes pipe thread cutting economical. Dies are available for the standard range of B.S.P. threads and alternatively, to Whitworth, U.S. standard, and Unified, within capacity of stock.



Ample Strength for the TOUGHEST JOB



STILLSON PATTERN PIPE WRENCHES

Heat treatment of the handle and jaw gives correct degree of hardness and prevents bending and breakages. Sturdy, light in weight and easy to handle, these wrenches are guaranteed against defects in material and workmanship.

THOS. CHATWIN & CO.

Victoria Works, Great Tindal Street, Birmingham, 16
Telephone: Edgbaston 3521-3



FIBREGLOSS HEAT INSULATION PRODUCTS

Rigid pipe sections for Steel and Copper tubes, all sizes

Resin Bonded Slabs, loose Wool. Also available in roll, strip, and blanket form. All ex stock from:

MONSELL, MITCHELL & CO. LTD.

Heating & Insulation Division,
67/73 Townsend Street, Dublin

PHONE 76282.

trade Topics

International introduce new products

INTERNATIONAL Boilers & Radiators Ltd. have announced the addition of a new accelerator to their range. The new accelerator, called Thermopak A1, is suitable for all domestic closed circuit heating installations from 15,000 B.t.u./hr. to 150,000 B.t.u./hr., and replaces five pumps in the present range (models CR1H, CA1B, CR1B, CP2H, and Multiflo). The main features which make the A1 an outstanding pump are its high power-to-size ratio, its wide range of performance and the fact that it can operate in any vertical or horizontal plane.

While these features of the pump are of particular importance, International regard the A1 as exceptional in all aspects of operation. For instance, the A1 is silent throughout its entire output range. It is also an extremely compact pump, measuring only 7½" in length and weighs 10lb. 8¼oz. Other features of the A1, which carries a two-year guarantee, are:—

Features

Electrical Connection: As the electrical socket is fitted on the accelerator it is necessary only to fit the electric cable to the socket to connect to the nearest power point.

External Capacitor: The capacitor is neatly plugged into the pump and can be withdrawn without tools. The electrical socket must first be disconnected—a useful safety measure.

Corrosion-Resistant finish: The cast-iron casing is protected inside and

Continued page four.



● W. J. R. Couchman.

Irish Shell and BP appointment

IRISH Shell and BP Limited have appointed Mr. W. J. R. Couchman Technical Officer, Domestic Heating Department. He is based at the company's Head Office in Fleet Street, Dublin.

Mr. Couchman, an I.P.H.E. contributor, has extensive experience in this field and comes to Ireland after more than five years with an associate company. He has carried out special engineering studies in domestic central heating in several European countries and is a founder member of the Domestic Heating Society in London, as well as being an Associate Member of the American Society of Heating, Refrigeration and Air Conditioning Engineers.

in brief...

TWO new showrooms have been opened by A. Bell & Co. (Eire) Limited at the company's premises at rear of 136 Botanic Road, Glasnevin, Dublin 6. The new showrooms, additional to the existing ones, are being used to display the range of special Bell fireplaces and the Dimplex range of radiators and heating appliances.

* * *

A 12-PAGE 2-colour brochure entitled "Survey of Kent Products," has been published by George Kent Limited. This gives a brief description of each product in the extensive range manufactured by the company, and is an enlarged edition of a publication of the same title published early in 1964. Copies of this new survey are obtainable on request from the company at Luton, England.

* * *

LUWA (UK) Ltd., due to further expansion of activities in the fields of comfort air conditioning, chemical process plant and air filtration, have moved their London headquarters to larger premises at 34/41 High Street, South Norwood, London, S.E.25.

IRISH PLUMBING & HEATING ENGINEER

Vol. 5. No. 4. JULY, 1965.

THE IRISH PLUMBING AND HEATING ENGINEER is the only publication produced in Ireland catering exclusively for the heating, plumbing and ventilation industries with a guaranteed circulation covering the Republic of Ireland and Northern Ireland every month.

Good news for all our A. L. Townsend readers—the serialisation of stage two of his work, "Plumbing," will begin next month.

This fully illustrated series will run to more than twenty parts and will take up from the first stage already serialised in IPHE.

We continue our series of reports from the major exhibitions for the industry with a report from Frankfurt Fair, which was held over with the intervention of last month's Directory issue.

Special Review subjects this month cover: (i) Hot water, pipe and room thermostats, thermometers, and temperature indicators; (ii) Heaters, including electric, electric surface, feed water, gas, immersion, oil and tubular; (iii) Review of valves.

●
Editorial and advertising offices:

Callaghan Chambers, 13/15
Dame Street, Dublin 2.
Tel. 56465-6.

London: J. T. Robson &
Son Ltd., 30 Fleet Street,
London, E.C.4. Tel.: Fleet
Street 4438.

Belfast: 26 Carnamena
Ave., Belfast 6.
Phone: 643095.



I'm not taking my coat off till you put the heat on.

New Capital Radiators now come in this protective pack. And what's more they're going to stay in this protective pack, throughout despatch and delivery. And you can leave the pack on during installation, too. No need to unpack them until the heating system's ready to go. It's all because we're so pleased with the new warm white primer. New Capital Radiators are now supplied ready-primed in warm white and it's a primer worth protecting.

NEW CONCEALED BRACKETS

Just fix brackets to the wall and lift the radiator on. Nothing shows. Nothing spoils the slim, elegant seamless rolltop look of new Capital Radiators. Your job of installation will be much simpler and quicker too.

Now there's more reason than ever for installing Capital Radiators. New primer; new packing; new concealed brackets; choice of 34 sizes in three heights in singles and doubles; trebles, angles and curves to order. Contact your supplier now. Or get on to us for full details.

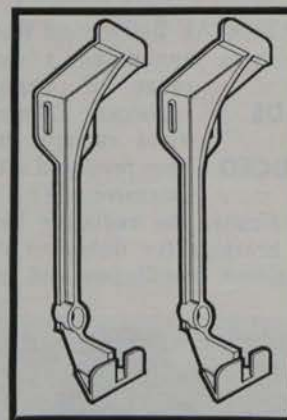

**NEW
CAPITAL
RADIATORS**

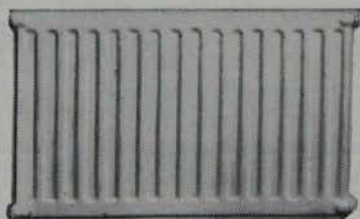

International
BOILERS AND RADIATORS LTD

Available from stock at the sole agents:

MONSELL, MITCHELL & CO. LTD.

Heating and Insulation Division, 67/73 Townsend Street, Dublin, 2. Telephone: 76282.

Three

trade Topics

from page two.

outside by a specially evolved paint. Thermal Cut-Out: The Thermapak A1 has a built in protection device to prevent the motor burning out, irrespective of the circumstances, and will automatically re-set itself.

Removable Stator: The stator may be changed without either draining the system or interfering with the pump mounting. Should it ever be necessary to change the stator it simply requires the undoing of four screws.

Air Removal: Air bubbles are removed automatically from the heating circuit.

New rads too

INTERNATIONAL Boilers and Radiators Ltd. have announced a new range of Capital radiators. The revised radiator has been produced after extensive market research. Firstly, the radiators have concealed brackets for unbroken design and simple installation and are

NEW RADS RANGE INTRODUCED



● The new Thermopak A1 Accelerator.



MONSELL MITCHELL HOLD HEATING CENTRE FUNCTION

MONSELL MITCHELL & CO. LTD. were hosts at a highly successful "Installers Evening" at the Irish Heating Centre to mark the introduction of the new "International" products. Pictured at the function were (from left): L. Peppard, Monsell Mitchell & Co. Ltd.; P. J. Duffy, heating contractor; Mr. P. J. Doyle, Manager, Heating Dept., Monsell Mitchell; Kevin Fogarty, contractor; J. Belliere, International Boilers & Radiators; Mr. Carley, Messrs. Thomas Lynskey; P. J. Johnson, International Boilers & Radiators.

slim and smooth with no top seam; secondly, they are finished in a warm white matt primer which may be left until the room is redecorated; and thirdly, all the radiators are individually packaged at the factory. This packaging does not need to be removed until the radiator is actually installed and thus it is protected from scratches in transit and during installation.

The radiators come in 17 sizes and 3 heights and are supplied complete with air cock and plug. In addition, International manufacture double, treble and quadruple panel radiators. Multiples of radiators can be made up at works to form long uninterrupted lengths. Angled radiators can also be supplied in single panels with one or two angles.

International also manufacture radiator shelves and heavy chrome-plated clip-on towel airers. Irish Republic: Monsell Mitchell & Co. Ltd.; Northern Ireland: International's Belfast Office at 128 Great Victoria Street.

L. STERNE'S diversification into the space heating business is now gathering pace. Recently one of its factories at Hillington, on Scotland's largest industrial estate, is being officially opened, although the company has been making refrigerator cabinets and boilers there for some time.

STERNES AND SPACE HEATING

● D.S.V.—the Danish Stoker & Boiler Company Ltd., of 38, Pearse Street, Dublin 2—have now put into operation a Service Division for the servicing of their oil burners, including commissioning and handing over to the client. A full complement of spare parts are carried in Dublin stock. After sales service will be given on a contract basis where desired, while a preventive maintenance service will also be carried out.

Anyone for Bermuda?

THE launch of the Thermopak A1 accelerator is being marked by a competition open to all installers who purchase one of these accelerators. The first prize is a 10-day holiday for two in Bermuda plus three days in New York and £100 spending money. Other prizes include: Ten days in Bermuda for two with £50 spending money, two six day double holidays in Rome with £20 spending money, and thirty Kodak 8 f 1. 9. Cine Cameras.

Installers may enter as many times as they wish, one entry for each Thermopak A1 bought, and entry forms are enclosed in the packaging for each pump.

Supermatic... or how 25% less for the oil companies can mean 33% more for you!

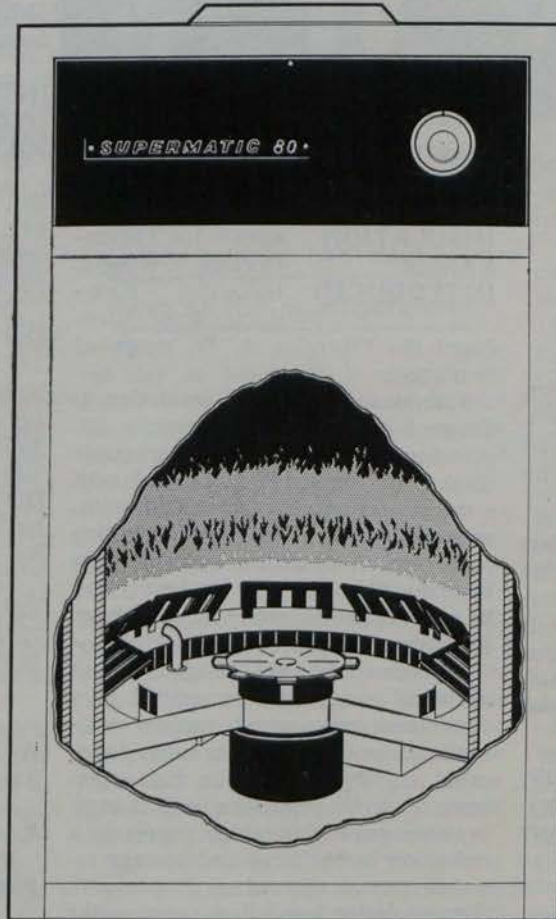

The guts of the Supermatic is the incredible Wall Flame Burner—incredible because it gives more heat, has a longer service-free life and has only one moving part—but incredible most of all because it burns 25% LESS FUEL than the standard pressure jet type burner. Yes! 25% LESS FUEL—The public are becoming increasingly aware that the Supermatic saves them *big* money every month. So, they're buying Supermatic more and more. Last year Supermatic stockists had on average a 33% increase in Supermatic sales. Supermatic are special in other ways too! You never have any wait for the Supermatic your customer wants—it's on its way to you within hours of your order arriving, and there are 18 different models to choose from, 44,000 to 300,000 BTU's.

So buy, stock, sell Supermatic... for your pocket's sake!

... and they don't only make the world's best boiler!



The Supermatic Skirting Radiator



The Supermatic Air Conditioner



The Supermatic Hot Water Convactor



The Supermatic Gyro-Jet Boiler



The Supermatic Gyro-Jet Air-heater and Hot Water Unit



The Supermatic Warm Air and Domestic Hot Water Unit



The Supermatic Industrial Warm Air Heater

PERRY HEATING APPLIANCES LTD HAMPDEN PARK EASTBOURNE SUSSEX. TEL: EASTBOURNE 51294/5/6

Agents: MESSRS THOS JEFFON LTD., 37 GEORGE'S QUAY, DUBLIN, 2, & 18 WESTMORELAND ST., DUBLIN. TEL. 72931

Published by ARROW@PS-Dublin, 1965



• At the Irish Heating Centre function were (from left): Messrs. F. Devine, Unidare Heating Division; N. Maguire, Project Manager, and T. Timmons, Service Engineer.

Unidare first to manufacture Wallflame here

NOW in production for the first time here, by Unidare Limited, is a 60,000 Bt.u./hr. Wallflame oil-fired boiler and a versatile skirting heating system.

The new Unidare boiler, the first Wallflame to be manufactured in this country, is designed to meet the ever-growing central heating market. It can be used with equal effect in conjunction with Unidare skirting heating, which has been already reviewed for IPHE readers.

The clean-lined boiler—it is fully automatic—is almost silent in operation and can be regulated to supply hot water only in summer. It has an efficiency rating of 82 per cent. and has a fuel consumption (continuous operation) of 4 pts. an hour maximum.



• Pictured with Mr. P. Luke, Unidare's Group Divisional Manager (right), is Mr. T. Gahan, Superintendent, Galte x Heating Department.

VAN DEN BOSCH Limited (Europa House, Wimbledon, London, S.W. 19), sole U.K.

INSULATION RANGE INTRODUCED

agents for Owens-Corning Fiberglas Insulation Products, have introduced the Fiberglas A. W. range of insulation.

Fiberglas A.W. range insulation is designed specifically for domestic applications. It is an off-white flexible blanket of fibrous glass bonded with a thermo setting resin to provide dimensional stability and good handling properties. Odourless and virtually incombustible, A. W. insulation can be used in temperatures ranging from sub-zero to 1,000°F.

Fiberglas A. W. insulation has sufficient strength to be applied in a continuous wrap-round method without clips or bands. It is easily fabricated on the job. The high resilience of A. W. insulation permits compression packaging which results in a reduction in handling and storage requirements of as much as 80 per cent. The insulation has full recovery to the original thickness. It is available in a full range of sizes.

trade Topics

INSTANT HEAT SOLDERING full heat is the main feature of a new soldering gun now available in this country from Millers Falls Co. Ltd. Available either as a Standard model,

No. 641, or a Heavy Dnty model, No. 642, both types incorporate dual heat, controlled directly from the double position trigger switch.

The Standard model, with a low heat at 100 watts and a high heat at 140 watts, is designed for work in the home and is also particularly suitable for electronic and electrical work. A built-in pre-focussed spotlight illuminates the working area. The Heavy Duty model, low heat 240 watts, high heat 325 watts, is a professional quality soldering gun.

The full range of Millers Falls tools, including Proto, are available through A. H. Massers—sole distributors of all Millers Falls products.

* * *

A NEW range of sanitaryware by Twyford's has been specially designed and manufactured

RANGE IS "VANDAL PROOF"

to reduce the possibility of vandalistic damage to a minimum. In both Ceramant vitreous china and Adamant glazed fireclay, the range comprises washbasins, w.c. suites and urinals, and in each case full use has been made of every modern technique of protective installation combined with foolproof fittings.

This sanitaryware can be installed therefore in all public toilets and washrooms with virtually total concealment of vulnerable pipework and fittings. The ware is, of course, strong enough in itself to withstand a considerable amount of rough or careless treatment.

In every case, waste outlets are taken through the wall, with service pipes, cisterns, and flush pipes installed behind the wall. The one exception to this is the No. 577/1 wall-mounted w.c. in glazed fireclay with high level cistern; here cistern, flush pipe and trigger-operated flush mechanism are encased in protective sheet steel covers.

SPECIAL REVIEW

THIS MONTH

H.W. Pipe and Room Thermostats,
Thermometers, Temperature Indicators.

THE VENNER Multiset timer is a synchronous motor-driven time switch with 24-hour dial. It is suitable for many applications demanding switching periods of varying duration on a 24-hour cycle, including the automatic control of lighting, heating and feeding systems employed for the development of Farm Stock, the control of laboratory equipment and test gear, kindling control for solid fuel heating systems, automatic sampling and process control.

The Venner Radiator fan control unit, type RFC, is designed to control output of forced air convection storage heaters having integral tangential fans to boost the output when required. This neat and compact unit incorporates a synchronous motor driven time switch and a five-position manually controlled rotary switch, providing instant selection of the desired heat output level at the required times.

The Seven-Day Programme Switch, Type PS 7, also from Venner, is particularly suitable for control of a heating system or similar installation operating to a weekly programme. The switch gear is operated by fitting a switching sector to the periphery of the dial, the leading edge of the switching sector being in line with the time of

IN this equipment review
we take a look at new
developments in the fields
covered by this month's
special review. (All claims are
those of the manufacturers).

the day at which it is required to switch "On." The range of Venner Time Switches is distributed in this country by Roper Brothers Ltd., 5 South Anne St., Dublin.

* * *

SPERRYN G.880 Series Composite Gas controls are manufactured in two sizes, the $\frac{1}{2}$ " size—suitable for controlling space heating appliances up to 50,000 B.t.u.'s output, and the $\frac{3}{4}$ " unit—designed for installations up to 100,000 B.t.u.'s capacity. Each control comprises a Thermomagnetic flame monitoring valve to control the main and pilot gas supplies, a spring loaded gas pressure governor, and a diaphragm operated relay valve.

The function of the Composite Controls is to provide correct lighting procedure, to maintain a constant burning pilot to ignite the main burner, to ensure closure of main and pilot gas supplies in the event of the pilot becoming extinguished. A constant pressure is also provided at the main burner, and an On-Off control of the main burners may be actuated by gas or electric thermostats, clock controllers, or other control devices.

A low voltage solenoid valve may be added to the basic unit operating a weep line servo system to the relay valve, enabling most forms of electric time and temperature control to be used. An integrated push button switch is also available for ignition. Thermo-couples are available in various lengths, together with a range of pilot burners, with alternative tips. The manufacturers are Sperryn & Co. Ltd., Birmingham, and supplies are available both in the Republic of Ireland and Northern Ireland.

* * *

ALTHOUGH the Maclaren type GAB thermostat is designed particu-

larly for control and protection of boilers and central heating systems, it has many other general applications. Its features include a short temperature sensitive bulb, an elegantly styled die-cast aluminium cover box and an easy read adjusting knob.

The sensitive, but robust snap switch mechanism is mounted inside its weatherproof casing and is protected against unauthorised interference by the insulated terminal plate. The temperature sensitive liquid filled bulb is normally connected to the mechanism by $1\frac{1}{4}$ " of inoperative capillary, just sufficient to allow for average lagging. However, where the bulb must be remote from the instrument head up to 40" of capillary may be supplied.

The Maclaren T-99 Mercury Switch Thermostat, horizontal series, are designed for use on 24-volt systems. It is fitted with variable heat anticipation, also with night cut-off. These thermostats control temperature by opening or closing electrical circuits to heating equipment in response to changes in room temperature. Maclaren Controls Ltd. are at West St., Glasgow.

* * *

WHITE-RODGERS Ltd., of Twickenham, who are represented in Ireland by Thomas Heiton & Co. Ltd., Dublin, have announced the introduction of their 180-1 Light Duty Room Thermostats, specially designed for the control of small motors, unit heaters, automatic burners, relays, motor starters, and low wattage electric heaters.

The unit has a bi-metal sensitive element with a large surface area to give quick response to temperature changes. An alnico magnet provides positive snap action to ensure a reliable performance and provide increased life for the heavy pure silver contacts. A touch temperature selector permits temperature setting in the dark or without reading the dials.

The same firm's 1A66 Double Role Electric Heat Thermostat is suitable for heavier duty commercial and domestic applications up to 10 Kw. It is extremely easy to install, being provided with its own flush mounting

Continued page nine.



● The Satchwell Presetter Type TDL.

The Irish Plumbing and Heating Engineer.

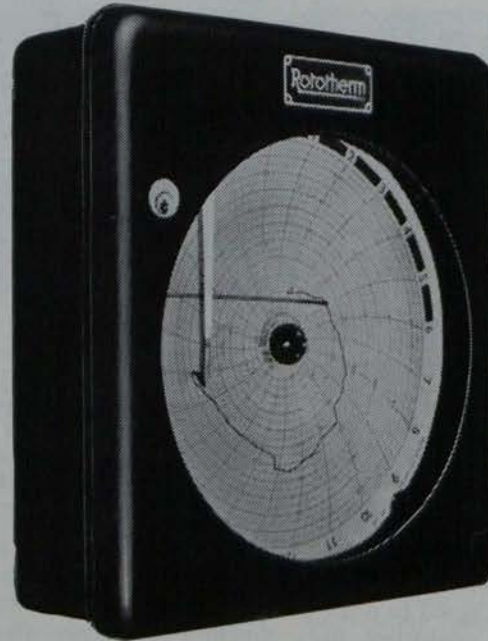

for measuring,
recording,
or controlling
TEMPERATURES
a-c-c-u-r-a-t-e-l-y

Rotothem

thermometers are visibly better!

Bi-metal • Mercury-in-steel • Vapour pressure Thermometers

THE ROTOTHEM PRECISION & INSTRUMENT CO., LTD.

Beechwood, Killiney, Co. Dublin. Tel.: Dublin 806566, and at Merton Abbey, London S.W.19.
Hollis St., New Basford, Nottingham. 87 St. Vincent St., Glasgow C.2.

**A NEW
PRODUCT**

"THE DUBOIS PLASTIC TRAP" (Regd.)

**A NEW
PRODUCT**

Provn. Pat. No. 38070/60.

**1½" and 1¼" diam. x 1½" seal "S" and "P" BLACK HIGH DENSITY
PLASTIC TRAPS**



Orthodox Shape!
Smooth Bore Tubular construction.
Outlets can be turned through 220°.
A two-piece trap at a one-piece price.
Outlet on 'S' trap turned to inlet forms
a through-bore bottle trap.
Frost and damage resisting.
Light weight = lower transportation costs.



Manufactured by:—

THE DU BOIS COMPANY LIMITED
15 Britannia Street, London, W.C.1

Telephone No.: **TERminus 6624-5.**

Telegraphic Address: **"Bleitrap, London."**

bathing beauty



"Perspex" Acrylic Sheet is a product of I.C.I. (Ireland) Ltd.
Look for the "Perspex" label.

First place for good looks always goes to the bath that's made from "Perspex" Acrylic Sheet. There's no mistaking the elegant finish and attractive colours (colours go all the way through the thickness of the "Perspex" Acrylic Sheet.)

Here are the vital statistics: "Perspex" Acrylic Sheet baths are light, durable and easy to install. Their smooth surface aids hygiene, for dirt just can't lodge there. "Perspex" Acrylic Sheet provides a surface that's amazingly easy to clean and retains heat excellently. And the cost is low. These are some of the reasons so many people will buy baths with the "Perspex" Acrylic Sheet label. (But we won't be surprised if you choose one for its beautiful looks alone.)

These baths are manufactured by:

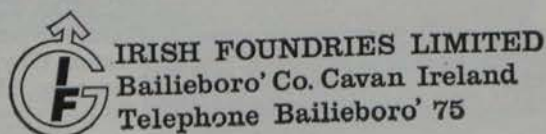

SPECIAL REVIEW

from page seven.

conduit box which has $\frac{1}{4}$ " knock-outs at the top, bottom and back. Wiring is from the front for quick positive connection. The unit has the great advantage of being able to control two separate 5 Kw. loads simultaneously, which makes it ideal for larger electric floor warming and other installations without the need for a contractor.

* * *

THE FIRST surface thermometer on the market designed specifically for small bore central heating systems is introduced by the British Rototherm Co. Ltd., Merton Abbey, London. Using this instrument, it is a simple matter to check boiler efficiency or heat loss for circulating pipes. It is also helpful when calculating radiator output and balancing systems to the desired value.

The thermometer—model 907—has a saddle—grooved to fit the $\frac{1}{2}$ -inch or $\frac{3}{4}$ -inch B.S.S. 659 small bore pipe diameters. A special feature of this saddle is that it can be rotated to keep the dial upright whatever the angle of the pipe. A phosphor bronze spring clip curved to fit flush to these pipe sizes, clamps to the sides of the saddle, holding the instrument in place.

A $\frac{3}{8}$ " size B.S.P. screwed thread with a 0.92" across flat hexagon has been added to the range of pipeline thermometers produced by the British Rototherm Co. Previously only a $\frac{1}{2}$ " B.S.P. size was available. The instrument has a co-axial head with a brass screwed fitting. There are three standard stem lengths: 3", 2 $\frac{1}{4}$ ", and 1 $\frac{3}{8}$ ". In the 1 $\frac{3}{8}$ " length the stem is countersunk to allow the bi-metal actuating element to be fully exposed.

* * *

KOSWA LTD., of Alton in Lancs., have recently introduced their 1WK Electronic temperature controller type E 1203 which is designed to control the temperature of heating installations in accordance with changes in the outdoor temperature.

The unit makes use of the thermister detectors which are fitted to the flow main and embedded in the outside wall of the building. Small changes in temperature are transmitted to the electronic control unit which modifies the boiler flow temperature accordingly. The unit in-

Continued overleaf

Nine

SPECIAL REVIEW

from previous page

cludes its own time clock to give the required heating programme.

The basic components of the IWK Electronic controller consist of a sensitive flow temperature detector, a similar outside temperature detector, a central control box, and the operating valve or motor. Koswa are represented in Ireland by Mr. H. C. Maguire, 13 Fitzwilliam Square, Dublin 2.

* * *

RECENT introductions to the domestic market from the range of Satchwell Controls Ltd. include the SA36 and the TDL "Presetter." The SA36 thermostat has a changeover switch and is designed to be clamped to a surface; for example the outer surface of a hot water tank to control the domestic HWS independently from the central heating system. Although it is envisaged that the SA36 will often be used with the Satchwell SML "Minival," its contents are rated at 15 amp. a.c. and thus suitable for other duties.

The "Presetter" incorporates a thermostat, thermometer and delay timer in an attractive housing styled by a leading industrial designer. It has been designed especially for those households whose heating requirements are not consistent enough for control by a regular timeswitch programme and the timer can be set to provide any delay up to 18 hours. After this time the heating plant will be automatically switched on.

Two electrical supplies are available from the "Presetter," one being continuous, suitable for either gas or oil-fired equipment, the other being switched by the inbuilt thermostat, and thus suitable for controlling a circulating pump or warm air fan. Simple adjustment of the control knob provides the householder with a convenient method of selecting heating requirements and the self-contained unit of timer and thermostat simplify electrical wiring—thus the Presetter enables reduced installation costs and economy of fuel.

- We have been asked by Monsell Mitchell and Co., Ltd., 67-73 Townsend Street, Dublin, 2, to notify readers that they are the sole stockists in the Republic of Ireland of the 'Sigmund' range of heating pumps. This information was inadvertently omitted from the entry in our 1965 Directory of Manufacturers, Agents, Representatives and Distributors.

check these features—

1. Robust portable stand folds up for easy transport.
2. Vice for cutting off, fitting unions, etc.
3. Precision machined Formers in high grade Mechanite.
4. Extruded alloy Guides housed in carrier to prevent damage and loss.
5. Safety Pin prevents accidents by securing Bending Lever in upright position when removing bends from machine.
6. Locating Bosses retain Bending Lever in position when changing Formers.
7. Adjustable degree of bend quadrant for repetition bending.
8. Produces good quality sets, double sets, saddle bends, etc., all to pre-determined measurements.

■ Only a Hilmor Machine has them all and they add up to Britain's best and biggest selling portable bender.

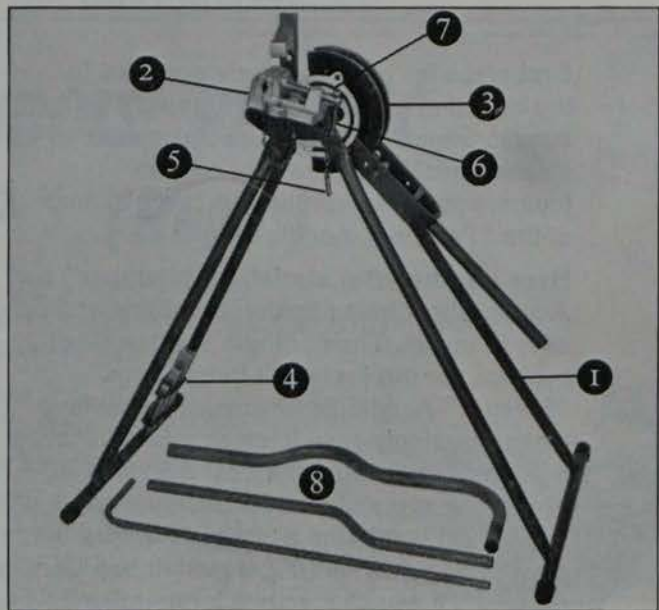

CAPACITY: GL.2B (illustrated) $\frac{1}{2}$ " to 1" BS.659 tube.
GL.3B $\frac{1}{2}$ " to $1\frac{1}{2}$ " BS.659 tube.
Machines with standard tools suitable for bending light gauge steel tube with same o.d. as BS.659 copper.

HILMOR LTD.
(Sales & Service)
Caxton Way,
Stevenage, Herts.
Tel.: Stevenage 881.
Grams:
Tubenders, Stevenage.



FRANKFURT FAIRGROUND LIKE A SMALL CITY

EACH year more and more Irish engineers visit the vast Hanover Fair exhibition. With its 5,500 exhibitors from 29 countries and 40,000 specialists in attendance, it must rank as the world's greatest engineering display. The Fair ground is a small city in itself, with its own buses, banks, restaurants and even its own mobile church.

Many of the exhibits are for the specialist but readers of this magazine would find plenty to interest them in the field of heating and ventilating. The accent of the whole exhibition is on industrial work, and one finds for instance very little relating to domestic heating and plumbing. Its main appeal would be to consulting engineers, larger contractors and to importers and representatives.

An enormous volume of business is transacted at the Fair, since foreign buyers find it extremely convenient to have all the leading engineering firms within walking distance of one another. Many business agreements are negotiated and representatives appointed. Language is no barrier as most continentals speak English extremely well.

It was surprising to have to search some time around the enormous Budrus stand before finding a boiler.

THE EXHIBITIONS

WE CONTINUE HERE OUR PROGRAMME FOR COVERAGE OF THE MAJOR EXHIBITIONS. THIS REPORT, BY A SPECIAL CORRESPONDENT, WAS DELAYED WITH THE INTERVENTION OF LAST MONTH'S SPECIAL DIRECTORY ISSUE.

This firm specialises in all forms of intricate castings as a service to other engineering firms and boilers form only a part of their programme. Another well known exhibitor was Loewe Pumpenfabrik. Their new twin Silenta ZV variable head pump on show has not yet been introduced on the Irish market, but I tip it to be another winner for Messrs. H. R. Holfeld.

A very large range of pumps and compressors were on view. I liked particularly the comprehensive range by Speck - Pumpen, Hamburg - Volksdorf, Farmsener Landstrasse 4. Their programme includes a well designed range of hot and cold water pumps as well as pressure sets and mobile pumps and sump pumps. Messrs. Lutz Maschinenbau, 6980 Wertheim/Main 2 exhibited a range of barrel and container pumps for oils, paints, chemicals, etc. Messrs. Alup were one of the largest exhibitors of air compressors.

Water and heating metering equipment were much on view. In this rapidly developing field, the firms of Aquametro AG., Basel 13, Murbachstr 34, Switzerland, and Bopp and Reuther GmbH, Mannheim - Waldhof W.G., were the most prominent. J. G. Merckens KG., Aachen, W.G., manufacture tank contents gauges, float switches and a clever tank over-

filling safety device. Messrs. Berkefeld-Filter GmbH, Celle, W.G., displayed a wide range of industrial and domestic water treatment plant. A number of their installations have been delivered to Ireland with German boilers.

The section dealing with industrial drying, ventilation and dust extraction was particularly impressive. Messrs. Benno Schilde AG., 643 Bad Hersfeld, W.G., are one of the leading firms in this field. Their roof extractor units were neat and well finished. Messrs. Ventilatoren Fabrik Oelde, Oelde, W.G., displayed a wide range of fans, heaters, pneumatic conveying and dust extraction equipment. Their fans, like most German-made fans, are quoted with very high efficiencies, a feature which is not generally striven for by British manufacturers.

Messrs. HY-LO GmbH., 3 Hanover, Escherstr, 25, W.G., had on display a selection from their wide range of small oil-fired boilers, portable oil fired heaters and some very keenly priced incinerators. Cooking equipment manufacturers were well represented. The makers of the Junomat series, Messrs. Burger Eisenwerke AG., had a very impressive display.

Messrs. Samson Apparatebau AG., Frankfurt/Main, Postfach 2488, are one of the most important manufacturers of control equipment on the

Continued overleaf

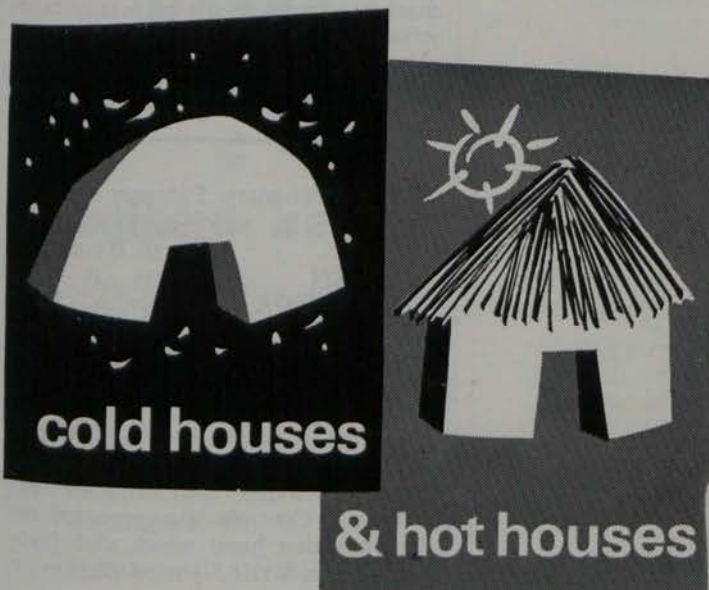

An igloo or mud hut? Not likely. But in case the impossible happens, you can rely on Aerobord to turn client's folly into a haven of comfort. Aerobord, the versatile featherlight insulating material that makes civilised places habitable. And clients happy.

FACTS ABOUT AEROBORD: As thermal insulation 1" thickness of Aerobord is equivalent to: 1.2" glass wool, 1.25" cork slab, 1.5" mineral wool, 1.8" softboard, 2.25" vermiculite, 2.5" wood wool cement slab, 3" strawboard, 3.5" asbestos insulating board, 6" vermiculite plaster, 40" brickwork, 50" concrete.

Manufactured in Ireland by

SOUTHERN CHEMICALS LIMITED, ASKEATON

AEROBORD



Eleven



How much is this costing you?

In time? In labour costs? In trouble and mess? Maybe you didn't know that you can replace the whole shebang with a hacksaw and a tin of Wavin cement—making a greater profit in the process? Take a look at the opposite page.

wavin

WAVIN Hard PVC Piping / for progressive plumbers.

Frankfurt well worth a visit

from previous page

continent. Their programme includes electronic, pneumatic and liquid expansion type temperature controllers, flow meters, control valves, etc. Thermostatic radiator valves were on display by Messrs. Armaturen Nerk Niederscheld GmbH., 634 Dillenberg/Hessen, Postfach 120.

A very attractive range of window and wall fans were shown by Benno Shottler KG., 1 Berlin 20S (Spandau). Their styling was superb. One most interesting display was the window fan shown by Luftomatic GmbH., 6800 Mannheim U3, 21-22, W.G. It consisted of a long tangential fan, the full length of the window, in an aluminium casing no more than 3" square. It has automatic shutters and can be built-in over or under a window or over a door, where it is practically invisible. A very neat solution to an old problem.

Those were but a few of the exhibits. The Irish Plumbing and Heating Engineer has a comprehensive catalogue of the Exhibition and will be glad to give names and addresses of firms in any category. The exhibition is indeed worth a visit, as it gives access to an international market, something we can easily take advantage of in Ireland in order to obtain the best equipment at the best prices.

THE revolutionary Futurum Kitchen Ventilator is now available here through Brooks, Thomas & Co. Ltd., who have been appointed sole distributors.

The appliance, which includes an extra vent at ceiling level for 100 per cent. ventilation, comprises a dual silent centrifugal fan extractor assembly. Controls are mounted on the extraction hood which also features a non-dazzle light to illuminate the cooker top.

trade Topics

ACCURATE metering of the most minute flows is the main advantage of the newly developed "Micro-Oil" Meter introduced by the Mechanical Meter Division of George Kent Limited.

**LOW-FLOW
OIL METER
INTRODUCED**

This latest addition to the Company's versatile range of oil meters measures flows in the range 1/100th Gal./hr. to 2 gal./hr. within accuracy limits of $\pm 0.35\%$. This incomparable low flow accuracy is particularly suitable for the metering of oil supplied to domestic heating systems with capacities up to 65,000 B.t.u.hr., or similar low-consumption applications.

Small and compact in design, the Micro-Oil Meter employs the well-proven rotary-piston principle of operation for its measuring chamber. A unique feature, however, is the incorporation of a double-acting "pump." This is primed at the rate of consumer draw-off and when full, ejects its capacity through the measuring chamber to the downstream side of the pump at a pre-determined flow rate. The liquid is thus metered in increments without interruption of the discharge flow.

WORKS ENGINEER

for

Southern Ireland

Interesting position offered to qualified HEATING ENGINEER with engineering company in the planning and production of high quality heating equipment.

We require a keen, energetic man and offer excellent salary with unlimited scope for the right man.

Age range 25-45.

Telephone CLONMEL 567.

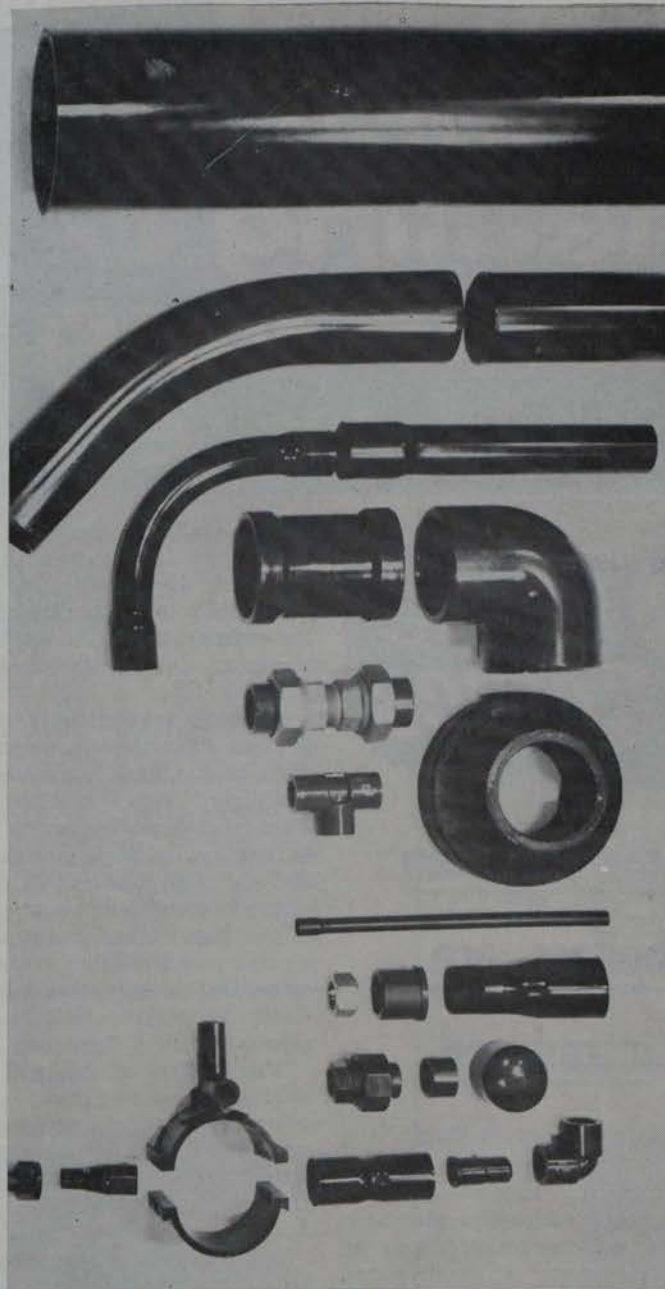

And how much would these save you?

Just a few items from Wavin's cold-water systems in Hard PVC. In all bores from $\frac{1}{2}$ inch upwards (to 12 inches, if you need!) Lighter and cheaper than copper. Full range of precision-made couplings, bends, joints, inlets and what-have-you. All fit together in seconds with a dab of cement.

Full details from your local stockist or Wavin Pipes Limited



Wavin Pipes Ltd., Balbriggan, Co. Dublin. Tel. 212260 (5 lines)

WAVIN Hard PVC Piping / for cold water plumbing!

industrial heating & ventilating

IN IRELAND



New Paxman boilers are introduced

AT trade receptions in Dublin and Belfast this month, Davey, Paxman & Company Limited—the Colchester concern which this year celebrates its centenary—introduced an entirely new range of boilers and heaters.

As the well-attended receptions were told, the new range incorporates many new and interesting features.

To be known as the Paxman Automatic, the boilers have outputs ranging from 1,500 lb./hr. to 6,000 lb./hr., and the heaters capacities from 500,000 B.t.u./hr. to 5,000,000 B.t.u./hr. The

smaller units in the range are capable of passing through an ordinary 3' x 6' 6" doorway, yet the manufacturers claim each one has an output far superior to that of any other contemporary unit of considerably greater size.

Although revolutionary in concept, the new Paxman Autonomic is at the same time a development along well-established and well-proven lines. This point is an important one. The heaters are, in fact, conventional cylindrical shell heaters of three pass wetback construction and the boilers of two pass wetback construction with a single pass smokebox economiser incorporated in the packaged unit providing an overall efficiency normally expected from a three pass boiler.

The features of the new range are as follows:—Low price; small and compact in size; absolute minimum of servicing; quiet in operation; light foundation weight; oil-fired versions are capable of burning oil fuel up to 3,500 secs. Redwood No. 1.

In addition, the steam boilers offer very rapid steam-raising from cold—about eight minutes—comparable with that formerly achieved only in a shell type boiler.

Constructed for standard working pressures of 65, 95 and 140 p.s.i.g., the new range of heaters is available in four sizes of frame, the difference between one frame size and another being in the number of tubes fitted.

UNIDARE Limited, Finglas, Dublin, have taken a controlling interest in the welding electrode equipment and manufacturing concern of Oerlikon Electrodes (G.B.) Ltd., whose factory is at Crawley, Sussex.

CONTROLLING INTEREST ACQUIRED

Unidare Limited will be the controlling partners with the famous Oerlikon Burhle Company of Zurich who have previously owned the entire shareholding of the British company. Oerlikon Electrodes (G.B.) Limited make a wide range of high quality welding electrodes under a technical "know-how" agreement from the Zurich parent. The British company has an exclusive manufacturing franchise for Oerlikon Electrodes and "know-how" covering the whole of Great Britain and Ireland together with a large part of the English speaking world, including Canada, the British colonies and protectorates, etc.

It is proposed to erect an entirely new modern factory on the Unidare site at Finglas in which manufacture for the Irish market and for export will be carried on. It is expected that this new factory will be in production in the Spring of 1966.

● **A GROUP** from the big attendance at the Dublin Davey, Paxman reception (from left): Messrs. P. Dormer (Concord Engineering Co.); T. H. Maidment (Leo Laboratories); Cyril P. Jenkins (Davey, Paxman); W. J. Beck (Dublin Airport Engineer); J. W. Jones-Hughes (Bloomfield Laundry); J. V. Crumlish (Dublin Health Authority), and T. Kiernan (Office of Public Works). (See also page twenty-five).

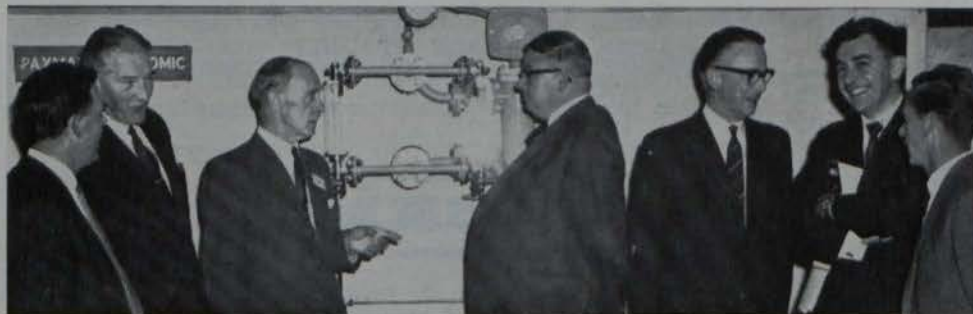



Here are five good reasons for specifying Biddle Heating Equipment

(write in and you can have
plenty more)

forceflo

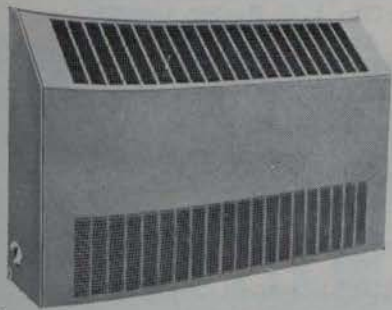

Trim - Elegant - Quiet . . . a guaranteed noise rating criteria under any conditions. When you have sound level problems specify Forceflo, because Forceflo is the only unit tested through all audible frequencies. There is a wide variety of sizes, outputs (up to 62,000 Btu/h) and designs; free-standing, concealed, remote and ceiling mounted. Standard Forceflo is 28" high. Other heights are in production and readily available for all applications.

warmline



Warmline is a highly efficient and adaptable method of heating ideally suited to modern building design. Warmline skirts the perimeter of a room to supply unobtrusive warmth. Three heights (12", 16", 20") are available, offering a high heat emission per foot run . . . inexpensively! Heat is distributed evenly over the run so that partitioning can be erected anywhere without interfering with output. A damper can be provided in each panel length for individual control. Warmline is available in two styles, both smart and neat in appearance. Easy to install and maintain, Warmline is perfect for long straight runs and fits smoothly around corners.

As one of the largest and most progressive organisations in the fields of heating, cooling, ventilating and air-conditioning in the United Kingdom, spreading warmth and goodwill is a Biddle tradition. They have made their presence felt in the comfortable conditions prevailing in many of the world's largest and most famous structures. Coventry Cathedral, Shell Centre South Bank, London Airport, Royal Festival Hall, Vickers House, The British Museum, The Old Bailey and The Queen Elizabeth II Hospital, Welwyn Garden City, are just a few of the buildings in the U.K. where Biddle installations are in operation. The wide experience and resources of the Biddle organisation are combined with imagination. Research and Development Engineers are continuously engaged in projects designed to meet the needs of modern industrial and commercial building for the best heating and ventilating equipment.

Your heating problems of tomorrow could be solved by a call to Biddle today.

Literature giving details of construction and dimensions is available from our offices or representatives.

uniflow



The modern styling and recognised efficiency of Biddle Uniflow Unit Heaters has made them a popular choice for many new factories and industrial organisations. Uniflows are available as horizontal or vertical discharge units for use with low, medium and high pressure hot water, low or high pressure steam. The horizontal unit is ideal for creating a flow of warm air along exposed walls, into narrow aisles and blanketing large doorways. The vertical unit is particularly useful in projecting heat downward, regardless of obstacles which may impede the airflow from a horizontal unit.

Uniflows are available for direct attachment to ductwork where a positive supply of outside air is required.

vectair



Vectairs are the last word in convection heating. Available as floor, wall, recessed and semi-concealed units. These outstanding convectors have heating elements that are unique in construction; the plate fins and tubes are mechanically bonded, metal to metal, ensuring the most permanent and efficient heat transfer yet made. Vectairs are available in a comprehensive range of sizes for hot water or steam systems—conventional or small bore. Installation is simple and the clean design harmonises with every decor.

coils

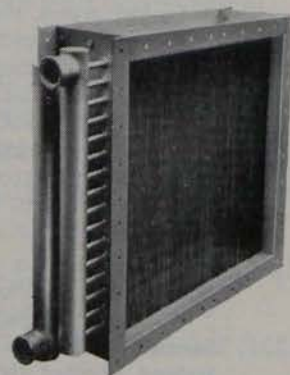

Standardised Biddle Coils have been designed to meet all the requirements of modern air heating and cooling equipment. These coils are of welded construction and are tested to 400 p.s.i.g. air under water for a working pressure of 200 p.s.i.g. Over 60 fin and tube combinations are available in standard casings ranging from 12" x 12" x 1 row to 25 ft nominal face area by 8 rows deep. High duty plus fins now permit face velocities of up to 600 ft/min. without moisture carry-over. Biddle Standardised Coils are available in four main types suitable for use with the normal heating and cooling mediums.

Forceflo and Uniflow both now available from stock in Ireland

AGENT FOR EIRE:

Thermal (Ireland) Ltd., 85 Lower Baggot Street, Dublin 2. Dublin 61237.

AGENT FOR NORTHERN IRELAND:

Thermal (Ireland) Ltd., (Northern Ireland Branch) Ltd., 26 Neills Hill Park, Belfast 5. Belfast 655759

F. H. BIDDLE LTD 16 Upper Grosvenor Street, London W1 (HYDe Park 0532-9)

biddle





Successful two-day symposium

ANDREWS - Weatherfoil (Ireland) Ltd. last month sponsored a successful two-day symposium on heating and air conditioning, the second day of which was opened by the Parliamentary Secretary to the Minister for Finance, Mr. James Gibbons.

Welcoming Mr. Gibbons, Mr. S. Neuman, Chairman, Andrews-Weatherfoil (Ireland) Limited, said: "We are honoured that he has been able to join us as in his capacity as head of the Office of Public Works he has a wide interest in all forms of building and in mechanical services for such buildings."

Andrews-Weatherfoil (Ireland) Ltd. is a new Irish company, a member of Powell Duffryn, the large international industrial group, and has a wealth of experience in heating and air conditioning. Tedcastle McCormick & Co. Ltd., with their extensive knowledge of the local market and fuel industry, are also shareholders in Andrews-Weatherfoil (Ireland) Ltd.

The symposium, which was held for

architects and engineers, was particularly important and topical in view of the growth of high rise building and the overall increase in living standards in Ireland, two developments which call for a high standard in heating, air conditioning and mechanical services for new buildings.

The symposium included an interesting film on the heating of multi-storeyed housing and illustrations of heating and air-conditioning in a wide range of buildings, including schools and universities.

HENDRON Bros. (Machinery) Ltd. have been appointed agents for the range of Midland Combustion equipment. The range includes Outflow heaters, steam, electric, and combined steam/electric, line heaters, oil pumping sets, Appel filters, etc.

Of boiler interest from Hendrons is the news that Orr & Sembower Inc., makers of the famous Powermaster boilers, have added another model to their range. The boiler, model J, is suitable for use with gas oil (35 secs.), and is available in sizes from 20 h.p. to 60 h.p. for hot water and steam, up to 150 p.s.i. The boiler is similar

● At the Symposium opening were (from left): (Mr. J. G. Barber, General Manager, Andrews-Weatherfoil (I.) Ltd.; Mr. Steve Neuman, Chairman; Mr. R. W. Newman, Director; Mr. J. P. Rehill, junr., Director, Andrews-Weatherfoil (I.) Ltd., and Joint Managing Director, Tedcastle, McCormick & Co. Ltd.

to the model 5L; however, the burner arrangement is more simplified.

* * *

NEW from F. H. Biddle Limited is the Coolflo range of floor and ceiling type coolers, designed for applications where noise is an important factor. The units can be fitted with heat exchangers suitable for either direct expansion refrigerants, chilled water or brine. In the last two cases the cooling coil can function as a heating element during the winter months by circulating hot water.

COOLERS RANGE BY BIDDLE

During the cooling cycle the unit also acts as a dehumidifier; a drain tray is built in to collect all the condensed moisture extracted from the air. This tray is fitted with a drain connection for the easy removal of condensate.

Both types can be supplied with a four-position switch giving three speeds and off, and can also be controlled by one or two room type thermostats coupled to a time switch to give fully automatic control. Models are available with one, two or three fans—models C20, C30, C45 respectively.

MR. L. A. KEOGH, Office Manager, Stewarts & Lloyds of Ireland Limited (left), receives a gold watch from Mr. J. A. Wood, Chairman, Stewarts & Lloyds of Ireland Limited, and also a Director of the Stewarts & Lloyds Group, to mark Mr. Keogh's completion of 30 years' service in S. & L.



From Birmingham, of Dublin parentage, Mr. Keogh has served the last

two years in Dublin, having come from the Birmingham offices of Stewarts & Lloyds to take up his present position as Office Manager on promotion.

INDUSTRIAL SECTION

Continued page twenty-nine

Northern Ireland monthly review

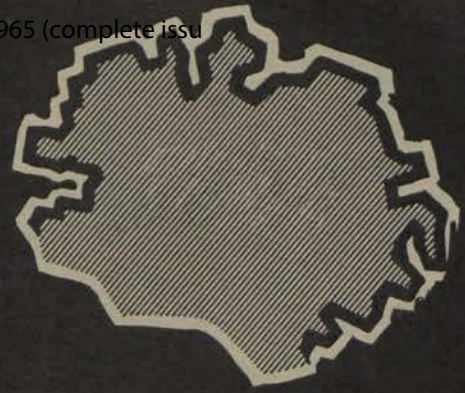

CLEAN AIR... is everyone's birthright

HOW TO GIVE THE NEW CLEAN AIR ACT A WARM WELCOME - WITH SMOKELESS SOLID FUELS

On the 1st July 1965 the Clean Air Act came into operation in Northern Ireland. As in other parts of Great Britain HOUSEHOLDERS can take advantage of the special National Coal Board Housewarming Plan. This scheme makes it simple and economical to install modern open fires and room heaters to burn the range of smokeless solid fuels now readily available. (In addition, to improving heating standards, many of these appliances will also provide domestic hot water and some central heating.) INDUSTRIAL USERS of solid fuels are equally well catered for. The Technical Service of the National Coal Board in Northern Ireland is ready to give free advice on solid fuel boiler plant and the Clean Air Act.

For information on industrial boiler plant and the Clean Air Act write or telephone to:

**N.C.B. NORTHERN IRELAND OFFICE
41 ARTHUR STREET · BELFAST 1
TELEPHONE: BELFAST 31671**

For advice on domestic installations write or telephone to:

**COAL ADVISORY SERVICE,
8 CASTLE LANE · BELFAST
TELEPHONE: BELFAST 29444**



for complete dependability

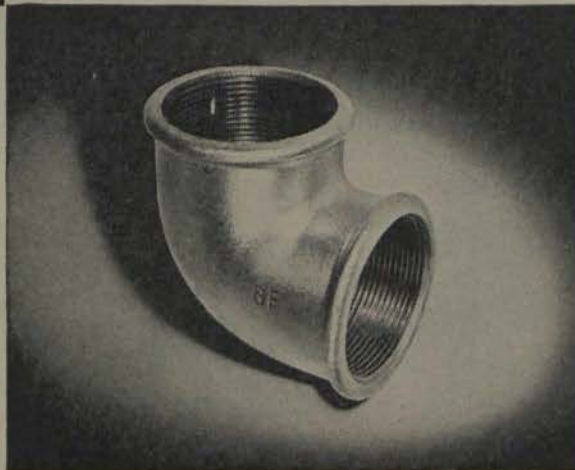

Use **GF** malleable iron tube fittings always with complete confidence. Perfect threads, true malleability and great strength mean time saved in installation and long, reliable life.

GF fittings are good for your goodwill; better to begin with; best in the long run.

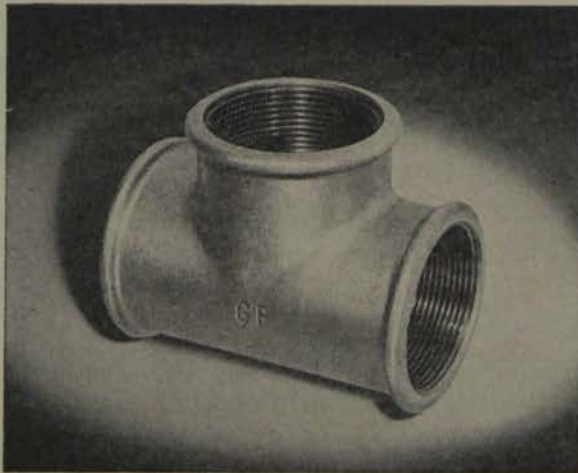

There are over 1,000 patterns and sizes from $\frac{1}{8}$ " to 6", black or galvanised, and every fitting is individually tested to 360 lb. p.s.i.

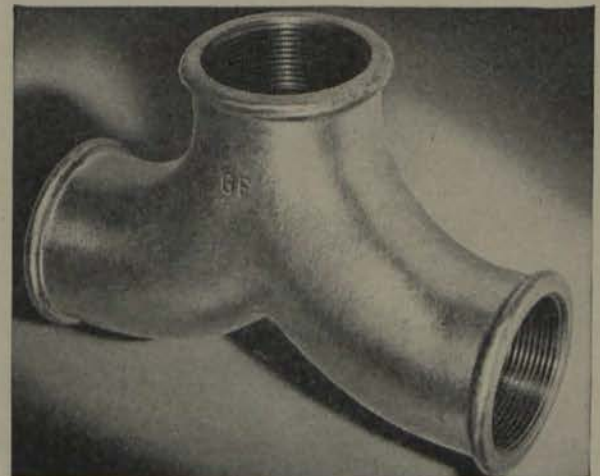

From your local stockist or from

LE BAS TUBE COMPANY LIMITED

24, Donegall Square Mews, Belfast.

Telephone: Belfast 22129.



Kosangas

serves all industries with best
quality lowest priced bottled gas



Steam Cleaner



Kosangas Tanker



Roofing Equipment

- *Kosangas* service aids productivity and effects economy not only in plumbing and heating, but in numerous other industrial and domestic applications.
- *Kosangas* is widely known as Ireland's most versatile industrial fuel: a modern, clean-burning, fumeless gas of high calorific value, leaving no deposits.
- *Kosangas* service has earned a high reputation for promptness and efficiency. Skilled technicians and fitters are available.
- *Kosangas* Propane is supplied in 73 lb., 24 lb., and 11 lb. cylinders. *Kosangas* can also be delivered in bulk into customer's own storage.
- *Kosangas* technicians can provide guidance on any industrial fuel problem without obligation.

If you would like a copy of our new Leaflet of Kosangas Industrial Applications please telephone our Industrial Sales Dept: Belfast 33221 or Dublin 74774

McMULLANS KOSANGAS (N.I.) LIMITED, 7 FOUNTAIN STREET, BELFAST, 1 TELEPHONE: BELFAST 33221
McMULLANS KOSANGAS LIMITED, O'CONNELL BRIDGE HOUSE, DUBLIN 2. TELEPHONE: DUBLIN 74774

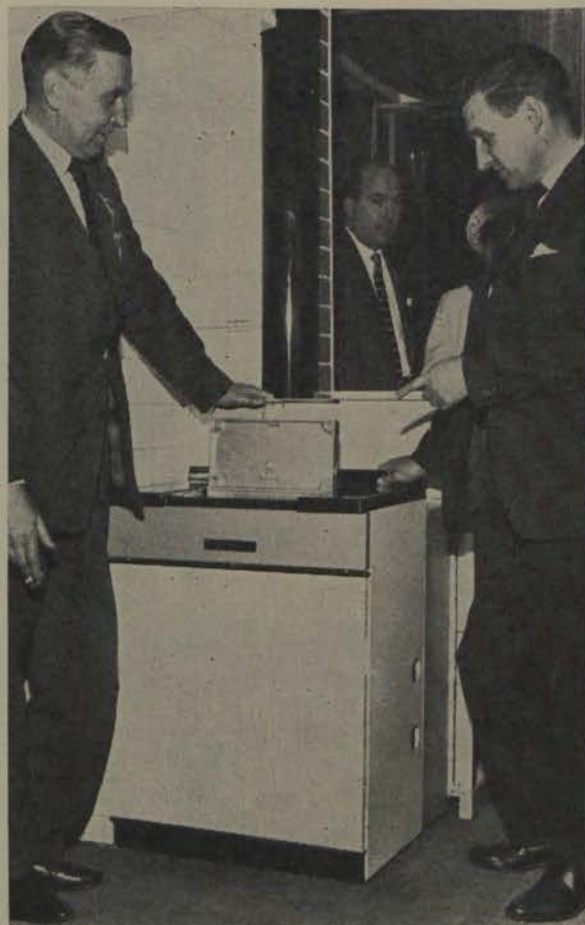

● Some of the trade personalities I met at Balmoral Show.

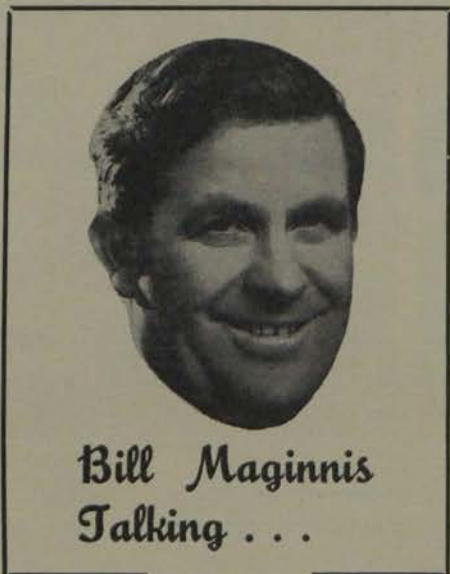

BALMORAL SHOW BIG SUCCESS

SHOW PROVIDES MANY USEFUL OPPORTUNITIES

THE recent Balmoral Show proved its usual interesting self. And quite apart from the excellent opportunities it offers on the business front, it provides many surprises in renewed acquaintances. Some of the friends I met are pictured here.



Twenty

By



F. R. McBRIDE, A.M.I.Mech.E., M.Inst.F.

Heating design and the architect

IN the design and layout of new projects, whether they be house, factory or offices, it is generally accepted that the Architect is the overlord and this is of course not unnatural, as when a client is requiring new construction his first overtures are to an Architect.

Discussions take place at which the client endeavours, and sometimes not very successfully, to outline his requirements both as regards the structure and the mechanical services. Once these have been settled, outline sketches are prepared; these in turn are discussed and if approved more detailed plans are produced.

The general layout of the building having been finalised, it is usual for the Architectural staff to start thinking about the services which have to be installed and at this point it is believed there is a breakdown in the liaison between the heating consultants or contractors and the designers.

IN most architects' offices one will find a complete library of all the materials which are used in building and to the credit of those concerned these are studied and the design is built up around the various standard specifications of the suppliers of the many materials which go into the modern constructions of to-day.

It would, however, appear, in many cases, that no attempt is made to facilitate the standard specifications presented by the suppliers to the heating industry.

The purpose of these words is to ask the members of a design staff to call in the consulting engineers at the earliest design stage, and if this is done many of the problems, and it may be said ill-feeling, which at times arises, could be avoided.

To illustrate what is meant by the above it is proposed to give a few illustrations which arise on project after project.

Let us take the most simple case which arises particularly in the case of house design. The modern trend, particularly in the lounge and living rooms, is to install windows of immense size and then to ask the heating engineer to heat that room to 70°F., at the same time leaving little or no room for radiator surface; this is, of course, assuming that the client does not want underfloor or hot air heating. How many times are drawings examined whereby the sill height is one or two inches too low to facilitate the installation of standard radiators or convectors.

The next point which often arises in the domestic field is the request to conceal all pipes; at the same time the residence is to have solid floors in certain rooms, thus practically making it impossible.

Then of course we get the regular classic—the boiler which is supposed to operate without a chimney. In other words the aesthetics of the house must not be spoilt by a chimney popping up over the ridge, whereas it should, as is sometimes done, be possible to make a feature of the chimney.

Many a well designed house has been spoilt by the erection of fuel stores which, while they may fulfill local authority regulations regarding cubic capacity, are such that for as little as 10 cwt. of fuel to be stocked it needs to be stacked to a height of five or six feet.

IN the fuel oil field how often do we see a bare storage tank erected on a few concrete blocks at the back of the house instead of being incorporated in, say, the garage or the solid fuel store.

When we come to consider the industrial units, one of the modern trends is to build steel framed boiler houses, possibly having walls of glass on at least two sides; while this form

of construction is most certainly attractive and lends itself to clean, bright and airy boiler houses, it does on the other hand create a noise level which for the operatives is somewhat of an endurance test and at times can be a nuisance to those in surrounding buildings.

MOST modern steam boilers, irrespective of the method of firing, usually require manual cleaning of tubes and very often the initial plans supplied for the boiler house are such that when the foregoing operation is to be carried out it would be necessary to either remove the wall or the windows.

When it comes to the plans for buildings such as office blocks, the boiler house is often located in an unapproachable basement. Boilers, etc., are usually placed on site at the very earliest stage of construction; if a major replacement has to take place it is necessary either to supply the replacement in a sectional form, after which it will be reformed in the boiler house, or alternatively it is necessary to carry out a certain amount of demolishing.

The boiler house may be a non-profit making part of a unit and not worthy of valuable floor space, but it should be remembered that it is an essential part of production in that it supplies a major portion of the environment necessary for working and as such surely is deserving of better siting and consideration than is usually given.

When it comes to the heating of large factory spaces, a problem to the heating engineer is often created by the provision of light and uninsulated roof coverings coupled with loading

Continued page forty-four

Twenty-one

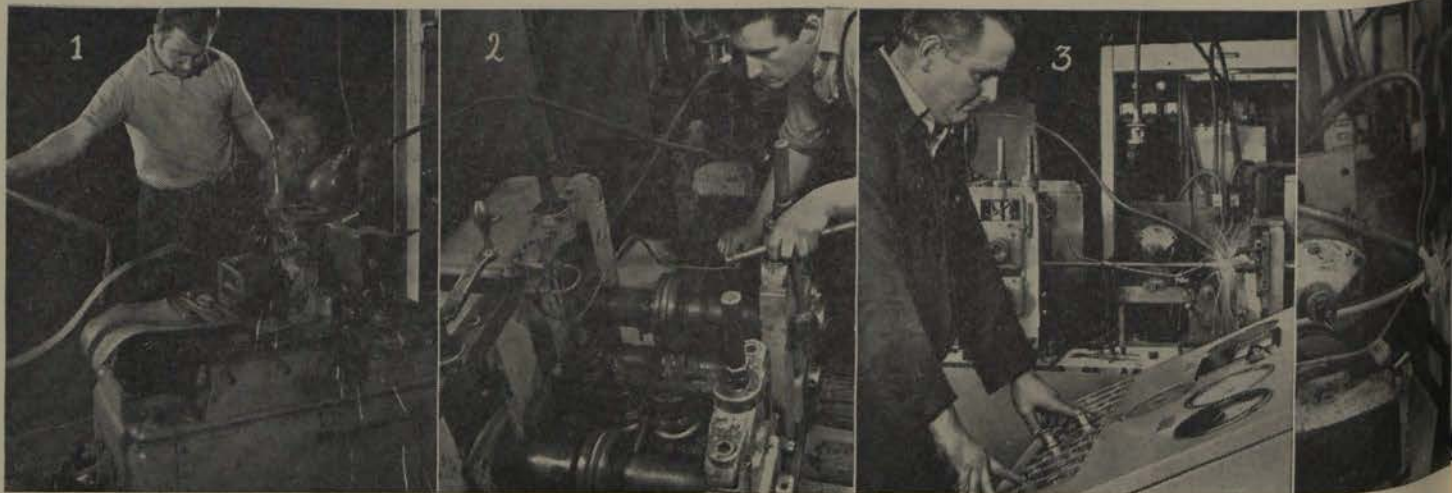

HOW IT'S DONE

1—The sparks fly as the end of a new coil of steel strip is squared off by guillotine and butt welded to the end of the previous coil set of forming rolls before welding takes place. **2**—The control console for the tube forming machine. The feature of the machine is an oscillator, which transmits the current of almost 20,000 amps necessary for this process. The temperature at the moment of welding is at which induction welding, on a radio frequency of 450,000 cycles, fuses together the abutting edges of the tube. The weld process specially developed for it by I.C.I. This provides the tube with a high rust resistance, enabling it to be installed on a point well in excess of that required under normal operating conditions. **3**—Plastic covered Gecal steel tubing in production. The attractive ivory coloured plastic coating provides the tube with a high degree of insulation. The paint spray gives the tube added protection, and provides a good flow-line and perfect results. The attractive ivory coloured plastic coating provides the tube with a high degree of insulation. The paint spray gives the tube added protection, and provides a good inspection. The paint spray gives the tube added protection, and provides a good inspection.

'GECAL' IS BIG TUBING NEWS FROM ORIENTAL

TWO new types of steel tubing which will substantially reduce the cost of small bore closed-circuit heating installations—they are only half the price of copper—are being introduced by the Oriental Tube Co. Ltd., a member company of the G.E.C. group and one of Britain's major producers of metal tubing.

New Gecal tubing is being produced, both metallised and insulated, in the same sizes as copper tubing ($\frac{1}{2}$ " and $\frac{3}{4}$ "), and is fully interchangeable with copper in hot water heating systems.

A £100,000 high speed tube-forming machine—the only one of its kind in Britain—has been installed at the company's West Bromwich Works to meet the demand for the new tubing. It is faster than conventional plant, and, by using high radio frequency current, ensures perfect welding and roundness to .001 inch.

GECAL is made from a special grade of cold-reduced close-grain steel, developed from the type used to make pressed steel radiators. As with steel radiators of reputable make, there is no danger of rust or corrosion when used on closed-circuit heating systems.

The tubing is subjected to the most rigorous tests. Every section is pres-

sure tested in a dip-tank to 200 p.s.i.—a point far in excess of that required under normal operating conditions. In addition, regular batch samples are taken from the production run and subjected to an "impossible" bending and flattening test to confirm their ductility.

Other samples are pressure "belled" to destruction to establish the strength of the weld. In this extreme test it is found that the weld remains intact while the steel tube splits.

RUST proofing is an important feature of both the new metallized and plastic covered Gecal. A phosphating process specially developed by I.C.I. provides the tube with a high rust resistance so that it can be stored "on site" without deterioration. Every bundle of 200 ft. of tubes (10 lengths) is also wrapped in bitumen cored waterproof paper for further protection.

The big advantage of the plastic covered tubing is its high degree of insulation. This obviates the need for special lagging when used beneath floors or in roof spaces. A $\frac{1}{2}$ " copper pipe 1° loses heat at approximately 32 B.t.u./hr. per foot run; with Gecal plastic covered tube, the loss is only

six B.t.u.'s per hour per foot run (these figures are based on 100°F temperature difference).

Gecal can be bent and fitted with the same ease as copper piping. All good quality compression and capillary fittings are suitable when jointing. The company recommends, however, that, with end-feed fittings of Nibco or similar type, use should be made of its own Gecaflux solder paint.

Other important advantages of Gecal are:—

- Low and steady price—because it is made from readily available home produced raw materials and is not subject to the wide price fluctuations experienced with copper.
- In use, its linear expansion is appreciably less than copper.
- Easier to transport and handle—it is lighter than copper.
- Stock control made easy—each bundle is individually wrapped and contains ten lengths of 20 ft. precisely.

RADIATION Parkray Limited have issued a consumer sales leaflet for their new "K" range of Parkray solid fuel room heaters. The full-colour leaflet covers all three models in the new range—the 33K, the 66K, and the 77K. Whilst detailing the improvements in the new models, including the up-to-date styling, thermostatic control, larger glass door and projection of only $4\frac{1}{2}$ " from the hearth, the leaflet also gives details of dimensions, performance and price.

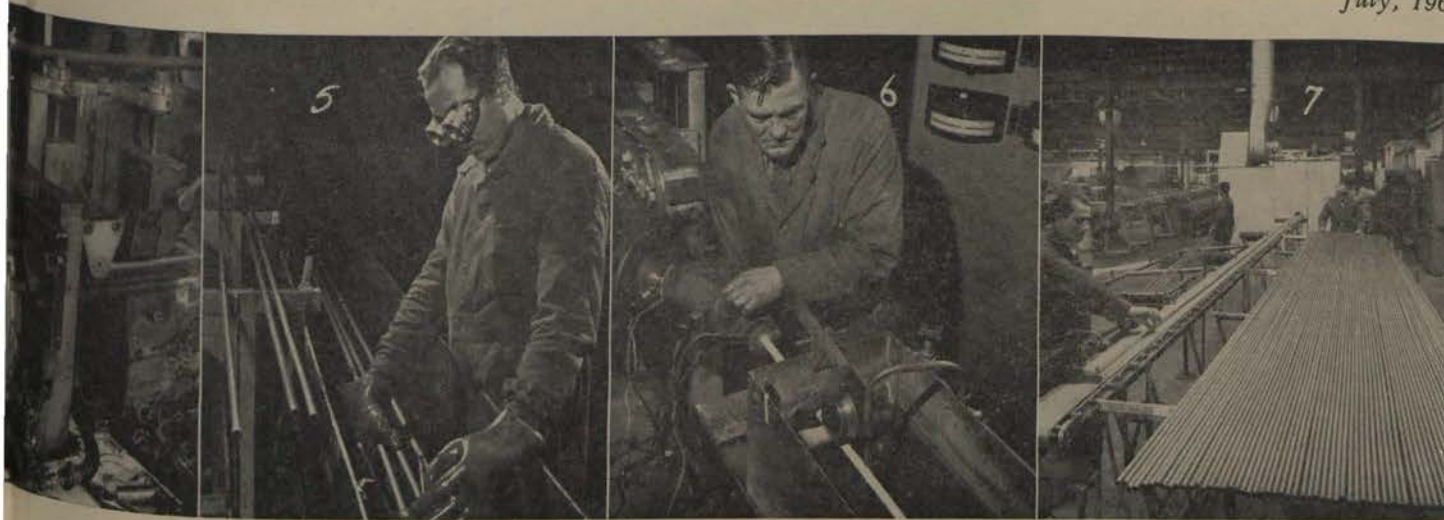

...beginning its run through The Oriental Tube Company's new £100,000 tube forming machine. 2—Tube passes through the final process—high radio frequency welding—is seen taking place behind the console. In the background is the 150 kW high frequency in the region of 1,800°C. 4—The vital stage in the production of new Gecal steel tubing—the point in the £100,000 machine where these two molten edges is a complete fusion—and the strongest part of the tube, 5—Every length of Gecal is subjected to a phosphating without deterioration. At the same time as phosphating takes place in this tank, the operator also runs a pressure test to 200 p.s.i.—plastic is extruded directly onto the metal tube through a hollow mandril—a process unique in Britain. It ensures a continuous conveyor belt brings the steel tubing from the metallised paint spray unit. The tubing is then rolled off onto the metal tressles for decorative top coating should this be necessary when the tube is installed on the surface.

Opening of Dunellen Ltd. factory by minister



● A view of the new Dunellen Ltd. factory.

A development of first rate importance to Northern Ireland—this was the observation of the Minister for Commerce, Mr. Brian Faulkner, when he officially opened the new factory of Dunellen Limited in Dunmurry industrial estate.

Dunellen Limited, the recently formed subsidiary of The British Steam Specialties Limited of Leicester, will manufacture indicating instruments, pressure gauges, vacuum gauges, thermometers and other allied equipment. This production was hitherto carried out at the BSS works in Leicester.

Mr. Faulkner, in performing the opening, said the development was of first rate importance to Northern Ireland. "Some developments mean more to us than others. This is such a development. Its main features are right in line with our requirements."

The product involved was a specialised one needing a high degree of skilled workmanship and which had a high value in relation to its weight and bulk. The promoters were of national standing and their presence in

Northern Ireland would further enhance the Province's reputation as an industrial area.

An interesting feature of the new venture is that only one man, Mr. A. Brookhouse, general manager of the new company, has been transferred from England.

Speaking of the factory's future—it is expected to employ 100 men in due course—the firm's chairman and managing director, Mr. J. W. Waudby, said: "I have little doubt of its success. I am sure that within a limited number of years—two or three—we will be coming again to ask for more space."

in brief...

APPOINTMENT

INTERNATIONAL Boilers and Radiators Limited have appointed Mr. P. J. B. Johnston as a representative to cover both Northern Ireland and the Republic.

Mr. Johnston was previously in charge of sales of domestic and industrial oils with Holmes, Mullins and Dunn Ltd., Belfast, Lobitos distributors. He is aged 31 and married.

International's Belfast office is now at 128 Great Victoria Street, Belfast.

* * *

● **TURNERS** Asbestos Cement Company is to establish a £500,000 factory

in Northern Ireland. It will manufacture products mainly for the building industry. Up to now the Northern Ireland market has been supplied largely from the company's factory at Widnes, Lancashire.

* * *

A **FOUR-PAGE** illustrated leaflet on their Kingswinford, Staffs., branch has been produced by Davidson & Co. Ltd., Sirocco Engineering Works, Belfast. The Kingswinford centre, opened two years ago, forms the Midland Area headquarters of the Sirocco organisation and is equipped to operate virtually as a self-contained unit.

Twenty-three

Northern NOTES



● This is a section of the extensive Joseph Blair Ltd. showrooms.

AN improved and speedy refractory design and construction service is now

IMPROVED REFRACTORY SERVICE

being provided for industry in Northern Ireland by newly formed Corbet-Cobb (Refractories) Limited, a combination of the resources of Eric Cobb and Company, Belfast, and of Robert Corbet & Sons, Glasgow and Birmingham, both of whom have been operating in the field of boiler setting, furnace and chimney construction all over Northern Ireland for many years.

A twenty-four hour service is now available and it is hoped that this will assist those who require urgent repairs to furnaces. Among the numerous contracts completed in the past are refractory settings to boilers at Ballylumford, Belfast West, Belfast Harbour and Coolkeeragh Power Stations.

Chimneys have been designed and constructed at numerous hospitals and schools including Altnageven, Gransha and Coleraine Hospitals, also Greystones and Garvagh Schools. Additionally new repair and alteration work has been carried out in many industrial plants, including I.C.I., Courtsaulds, British Enkalon, Stevensons, Moygashel Mills and Chemstrand.

* * *

GLOW-WORM have introduced a new gas-fired room heater to their range of heaters and central heating appliances. Enclosed in a fine grain tola wood cabinet, the Monaco heater will blend

NEW GAS ROOM HEATER

JOSEPH BLAIR OPEN NEW SHOWROOMS

MESSRS. Joseph Blair Ltd. (Church Lane, Belfast), the old-established firm of Builders and Plumbers' Merchants in Belfast, have just completed their new plumbing showroom.

This Showroom is intended primarily to be a service to architects, builders and master plumbers, but is open to the general public as an aid to them in choosing new equipment to be installed by their local builders or plumbers.

On permanent display there will be a wide and varied selection of units. And an indication of the comprehensive scale of the display is that it includes 12 complete bathroom suites, five complete fitted kitchens, 20 stainless steel sinks, etc.

with every taste in decoration and is in itself a very handsome piece of furniture. Since special provision has been made to allow greater flexibility in fixing arrangements, it can be fitted into a fireplace, or against a wall, or mounted on the wall itself.

The Monaco runs quietly with no heating or cooling-down noises and heats up quickly and efficiently. It provides both radiant and convected heat for a really large room, has automatic ignition and an adjustable thermostat with eight settings up to 85°F. The controls are recessed to prevent accidental damage, but with ease of access for finger-tip touch control, and for replacing the governor and ignition battery. The Monaco has a cast iron heat exchanger and is fitted with a chrome-plated reflector and safety guard which is easily removable for cleaning.

* * *

● ROBERT Maclaren & Co. Ltd., Glasgow, have changed their name to Maclaren Controls Ltd. The company's address has been changed to 333, West Street, Glasgow, C.5.

A UNIQUE BOILER-TUBE CLEANING UNIT!

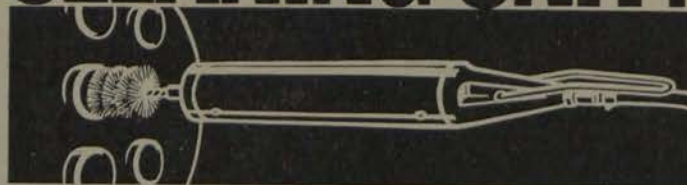

The Ferret is a completely unique type of boiler-tube cleaning unit. Attach it to a standard tube brush and it will creep along the tube—without revolving—and without any need for manual pushing and pulling! When it reaches the tube end, the double thrust action then reverses and the Ferret returns—ready for the next tube!

- THE FERRET**
- * Cuts labour time—no manual pushing and pulling
 - * Does away with extension rods
 - * Gives cleaner tubes
 - * Works quickly

For Publication No. 208, or a demonstration in your own plant, contact:

HALPIN & HAYWARD LTD.,

Unity Buildings, 16/17 Lower O'Connell St., Dublin, 1. Tel.: Dublin 48638, and 589 Upper Newtownards Road, Knock, Belfast, 4. Tel.: Dundonald 3212.



● DAVEY, PAXMAN & CO. LTD. recently introduced their new boilers range at receptions in Belfast and Dublin (see page fourteen). Our picture at the Woodbourne Hotel, Belfast, this month shows (from left): Mr. R. A. S. Gimson, Sales Director, Davey, Paxman & Co., Ltd., addressing the attendance.

LONDON KINGSWAY LIMITED (The Avenue, Egham, Surrey), the oil burner and accessory manufacturers, recently received a visit from their Irish agent, Mr. W. H. Leech.

Mr. Leech is the sole Irish Agent for Landon Kingsway Equipment and was appointed by them in 1959. He was met at London Airport by Mr. R. F. Landon, Sales Director of Landon Kingsway Limited, and taken to the Egham Works.

The purpose of his two-day visit was to discuss new products and make plans for the future, as well as to inspect Landon Kingsway's new works and offices, which they moved into nine months ago.



Building Centre gets under way

WHILE still waiting its formal opening the Building Centre of Northern Ireland, under its Director, Mr. Shane Belford, B.Arch (L'pool), A.R.I.B.A., is already making its impact on the industry.

The new Centre, at 4 Arthur Place, Belfast 1, now has its information service operating and is mounting a permanent exhibition of building products and a comprehensive reference library.

The Centre—it will be formally opened in the early autumn—was established jointly by local architects, building contractors, engineers and quantity surveyors to serve the industry in Northern Ireland.

STEEL Radiators Limited have announced a new range of panel radiators. The range **NEW 'SUPER' RAD FROM STEEL RADS** will be known as the Stelrad Super radiators. The general design of these,

idity of the Stelrad Standard, has been slimmed to keep abreast of modern demands. The pitch of the vertical waterways has been narrowed and the header has been reduced in size.

The Super will be available in the following heights: 12", 17", 23", 29", in both single and double form.

In order that the look of this rad-

iator may be further enhanced, they will be sold with a stoved primer finish in a warm white; and in an endeavour to ensure that our customers receive this radiator in perfect condition each radiator will be individually wrapped. Entirely new brackets have been designed for use with the new range.

A NATIONWIDE REFRACTORY CONSTRUCTION SERVICE !!

Boiler Setting
Refractory Engineering
Furnace Construction
Chimney Construction

Design and Construction of all types of Refractory Installation.

Corbet-Cobb Refractories Ltd.

4a JENNYMOUNT INDUSTRIAL ESTATE

NORTH DERBY STREET — BELFAST 15

Telephone: BELFAST 748729.

Also at GLASGOW - BIRMINGHAM - READING

FOR ALL
CLOSED-CIRCUIT HEATING

NEW GECAL

beats copper
all the way



New Gecal is a special grade of cold-reduced close-grain steel tube, phosphated by a new I.C.I. process against rust and corrosion. It's as good as copper – and better. It's also cheaper. **New Gecal** comes in two grades – Metallized and Plastic Coated. *Every single foot is water tested to a pressure of 200 p.s.i.* It can be bent as easily as copper – connected with compression or capillary fittings in exactly the same way as copper. It is fully interchangeable with copper pipe, but lighter and easier to handle and transport. *Supplies are assured, and prices stable.* **New Gecal** Metallized grade is just over *half the price of copper* – even when copper is at its lowest price. The Plastic Coated grade is only *two thirds the price of copper* – and, because it needs no lagging, can make a big reduction in installation costs. In fact, installation costs can be cut by as much as 42%.

Twenty-seven

MALLEABILITY PROVED BY 'IMPOSSIBLE' TESTS

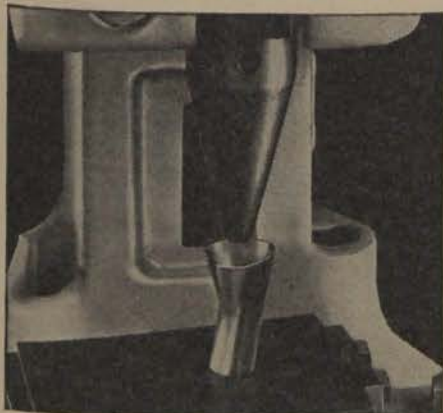

NEW GECAL is welded in long lengths by a new process – high radio frequency welding. Because the weld is *continuous*, it can be bent to the maximum without leaking. Even under heavy hammering and the grossest mechanical distortion, NEW GECAL remains water-tight. When NEW GECAL is 'belled' on a press until it splits, the tear is always away from the weld. *The weld is actually stronger than the tube.*



EASY TO USE

NEW GECAL can be bent as easily as copper and used with any copper fitting – capillary or compression – and used in every case where copper tube would be. When NEW GECAL plastic coated is used with capillary fittings the plastic sleeve should be cut longitudinally along the tube for about 4". After jointing the sleeve can be replaced and secured by adhesive.



THE ORIENTAL
TUBE COMPANY LIMITED

(a wholly owned subsidiary of
The General Electric Company Limited)

CHURCH LANE, WEST BROMWICH
STAFFORDSHIRE

Tele: West Bromwich 0044

Twenty-six

SAVE OVER £15 ON AN AVERAGE INSTALLATION

In a typical 3-bedroomed semi-detached house, you can save 42% of the cost of installing copper, with NEW GECAL Metallized. And 34% by using NEW GECAL Plastic Coated – which also saves the time and cost of lagging.

A rough indication of costs:

Copper £37.9.8
New Gecal Metallized £21.17.6
New Gecal Plastic Coated £24.15.10

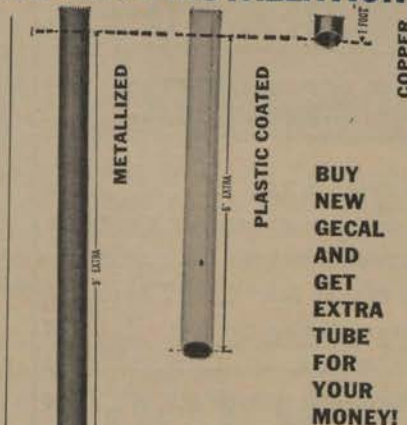

With NEW GECAL you get far more tube for your money. Buy a foot of $\frac{1}{2}$ " copper and then spend the same money on buying NEW GECAL – and just look at the difference in lengths! NEW GECAL $\frac{1}{2}$ " Metallized gives you nearly 9" extra – 21" in all. NEW GECAL $\frac{1}{2}$ " Plastic Coated – over 6" extra (18" in all). Savings for $\frac{3}{4}$ " tube are just as great. (Based on average price of $\frac{1}{2}$ " copper pipe between June 1964 and May 1965).

SPECIFICATIONS

NEW GECAL METALLIZED

NEW GECAL Metallized Grade is a steel tube, phosphated by a specially developed I.C.I. process for rust resistance, and sprayed with a metal paint to give an attractive finish. It is fully interchangeable with copper pipe and satisfies all the physical and dimensional requirements of BSS 659.

Net Prices to Installer $\frac{1}{2}$ " nom. bore 9½d per foot
..... $\frac{3}{4}$ " nom. bore 1/0d per foot

NEW GECAL PLASTIC COATED

NEW GECAL Plastic Coated Grade is a rust and corrosion resistant phosphated steel tube, sheathed in an ivory coloured plastic which makes lagging unnecessary when the pipe is used beneath floors or in roof spaces. It is fully interchangeable with copper pipe and satisfies all the physical and dimensional requirements of BSS 659. No painting is necessary – although the plastic coat is an excellent base when painting is desired.

Net Prices to Installer $\frac{1}{2}$ " nom. bore 10½d per foot
..... $\frac{3}{4}$ " nom. bore 1/2d per foot

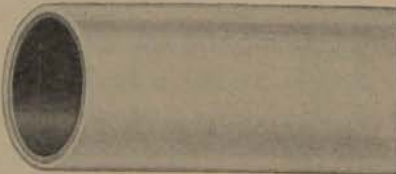

TAKE ADVANTAGE NOW OF THIS SAMPLE OFFER

- Please send me literature with full details of NEW GECAL
 - Please send me at a special discount a Sample Pack (200 ft – 20 ft x 10) of ONE ONLY of the following:
 - New Gecal Metallized $\frac{1}{2}$ " for £7 (normal price £7.18.4)
 - New Gecal Metallized $\frac{3}{4}$ " for £9 (normal price £10)
 - New Gecal Plastic Coated $\frac{1}{2}$ " for £8 (normal price £8.15)
 - New Gecal Plastic Coated $\frac{3}{4}$ " for £10 (normal price £11.13.4)
- OR
- (400 ft. New Gecal Plastic Coated $\frac{1}{2}$ " } for £26 (normal price £29.3.4)
(200 ft. New Gecal Plastic Coated $\frac{3}{4}$ " }

Put ticks in the appropriate boxes. Send this Coupon to the address below.

NAME

NAME OF COMPANY

ADDRESS

NAME OF USUAL MERCHANT

K

INDEX TO ADVERTISERS

Airnesco Products Ltd.	24
Alliance & Dublin Consumers' Gas Co. 33	
Andrews-Weatherfoil (I.) Ltd.	44
Asbestos Cement Ltd.	Cover (iii)
Belco Manufacturing Co. Ltd.	38
Biddle, F. H., Ltd.	15
British Berkefeld Filters Ltd.	29
Brooks, Thomas & Co. Ltd.	30
Chatwin, Thomas & Co.	1
Clohmel Engineering Works	13
Clyde Fuel Systems Ltd.	43
Corbett-Cobb (Refractories) Ltd.	25
Danish Stoker & Boiler Co. Ltd.	29
Du Bois Co. Ltd., The	8
Fordham Pressings Ltd.	Cover (ii)
Green, A. P., Refractories Ltd.	28
Hendron Bros. (Machinery) Ltd.	42
Hilmor Ltd.	10
I.C.I. (Ireland) Ltd.	9
Le Bas Tube Co. Ltd.	18
Lincoln Furnaces Ltd.	35
McMullans Kosangas (N.I.) Ltd. ..	19, 41
Mono Pumps Ltd.	38
Monsell, Mitchell & Co. Ltd.	1, 3
National Coal Board	17
Oriental Tube Co. Ltd., The	26, 27
Perry Heating Appliances Ltd.	5
Pillinger, G. C., & Co. (Ireland) Ltd. 34	
Quadrant Engineers	43
Rototherm Precision & Instrument Co. Ltd.	8
Satchwell Control Systems Ltd. Cover (iv)	
Saunders Valve Co. Ltd.	40
Southern Chemicals Ltd.	11
Tylors of Ireland Ltd.	39
Unidare Ltd.	Cover (i)
Wavin Pipes Ltd.	12, 13
Worthington-Simpson Ltd.	36

INDEX TO ADVERTISERS

The A.P. GREEN GUIDE TO REFRACTORY MAINTENANCE



PROTECTION

1 Use SAIRSET refractory cement for laying-up all types of firebrick. Protect new and existing brickwork with a coating of SAIRSET. Seal cracks—reduce risk of spalling and slag attack. SAIRSET is available in $\frac{1}{2}$ cwt., 1 cwt., and 2 cwt. drums ready mixed. It should be in your maintenance store.

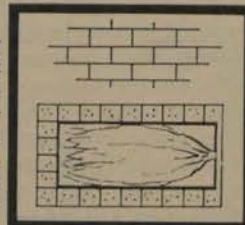

REPAIRS

2 Repair damaged walls with HYBOND plastic refractory. Can be used for small gaps or the complete wall or arch. For extreme temperatures use HIGH ALUMINA PLASTIC. HYBOND is delivered in 1 cwt. cartons sliced ready for ramming-in.



RE-LINING

3 Avoid intricate brickwork and special shapes by lining with KAST-SET refractory concrete. Simply mix and pour. When an insulating refractory is required for furnaces use KAST-O-LITE. Monolithic linings are economical on fuel and simplify maintenance. A. P. Green refractory concretes are sold in 1 cwt. bags.

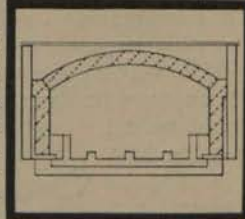

**SAIRSET · KAST-SET
HYBOND · KAST-O-LITE**

Are all available from
DUBLIN—
Brooks Thomas
Dublin 41841.
BELFAST—
Corbett-Cobb
Belfast 748729.



A. P. Green Refractories Limited
York House, Wembley

Tel: DILIGENCE 0455 Telegrams: GREENCO WEMBLEY Telex: 262755

More and more
house-owners want
softened water...
...and filtered water
—so specify
these
BERKEFELD
models

There's a special pleasure in using soft water. The best softeners for all domestic needs are British Berkefeld Mains Softeners filled with 'Amberlite', an extremely high capacity resin, and (most important this) coated inside with plastic for protection against salt corrosion, thus making them 'long-life' models. Easy to instal and maintain. In mild steel with cream cellulose finish. Capacities 650-2,500 gals. between regenerations. Price from £50. ▶

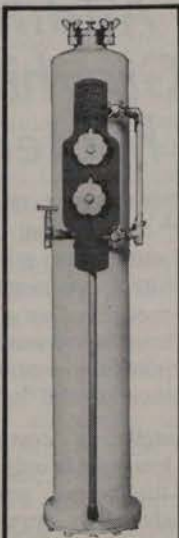

Whenever there's the least doubt about the water supply, a Berkefeld Sterasyl filter is needed. It is the only type fitted with the unique Sterasyl candle, which not only traps water-borne disease germs, but destroys them. Pattern HN (illustrated) is in brass chromium plated, complete with taps and fittings £7.10.0. ▶



Industrial models of both water softeners and filters also available.

MODERN WATER TREATMENT CALLS FOR

BERKEFELD

British Berkefeld Filters Ltd.

Dept. 244, Cannon Lane, Tonbridge, Kent, England · Tel: 2255

In Dublin: G. Reid, 16 Fade Street, Tel: 76009.

Industrial Section

Continued from page sixteen



● In association with Welding Services Ltd., 16 Amiens St., Dublin, R. Broderick & Sons Ltd., 43 Dame St., demonstrated the new McCulloch portable arc welder to more than 200 members of the industry at Crofton Airport Hotel. At the demonstration were (from left): Messrs. T. Carroll, Sales Engineer, Brodericks (the McCulloch distributors); D. McAllister, do.; Mr. H. M. Gray, Welding Services Ltd., and Mr. K. J. Broderick.

NEW D.S.V. SOOT-VAC BOILER CLEANING APPARATUS

A new and dust-free type boiler cleaning apparatus which permits rapid and thorough cleaning of boiler flame-tubes to be executed without waiting for the soot to cool is now available. The new DSV/SOOT-VAC comprises a pistol-operated brush and a cyclone or blower mounted on a 3 cu. ft. cylinder containing a disposable and fire resistant soot collection bag. The pistol itself incorporates a tape magazine in which steel tape is mounted on a reversible spool driven by an electric motor, equipped with a clutch and gear box with cog wheel and worm drive.

To operate the equipment, the operator simply inserts the nozzle of the pistol into the flame-tube, in which position the entire pistol is self-supporting. Finger pressure on a trigger uncoils the steel tape and thrusts the wire brush into the tube. A distinct change in the motor's pitch indicates when the brush has reached the end of the tube, whereupon the operator can retract the brush back into the nozzle by further pressure on the trigger.

A feature of the DSV/SOOT-VAC equipment is that the wire brush does not revolve during its passage of the tube. A revolving action would have the effect of packing the deposits on the walls of the flame-tubes, whereas in this case the brush, which is of greater diameter than either the tube or the nozzle, effectively scrapes the tube walls clean in the course of only one forward and one return stroke.

The pistol ensures efficient suction for removal of the soot. In addition to supporting the mechanism, the mouthpiece seals the tube completely, thus ensuring that the loosened soot and other matter can only pass through the tubes into the collection cylinder—it cannot escape into the boiler-room. The design of this mouthpiece or nozzle also enables the wire bristles of the brush to flex during their passage of the tube.

The blower, which is mounted on top of the soot container, is air cooled.



★ Demonstrations on Request.



DANISH STOKER & BOILER CO. LTD.

38, PEARSE STREET, DUBLIN, 2. Telephone: 72104.

Twenty-nine

A NEW and dust-free type of boiler cleaning apparatus, which permits rapid and thorough cleaning of boiler flame-tubes to be executed without waiting for the soot to cool—is now available from the Danish Stoker & Boiler Co. Ltd., 38 Pearse St., Dublin. The new apparatus comprises a pistol-operated brush and a cyclone or blower mounted on a 3 cu. ft. cylinder containing a disposable and fire-resistant soot collection bag. The pistol itself incorporates a tape magazine in which steel tape is mounted on a reversible spool, driven by an electric motor, equipped with a clutch and gear box with cog wheel and worm drive.

To operate the equipment, the operator simply inserts the nozzle of the pistol into the flame-tube, in which position the entire pistol is self-supporting. Finger pressure on a trigger uncoils the steel tape and thrusts the wire brush into the



tube. A distinct change in the motor's pitch indicates when the brush has reached the end of the tube, whereupon the operator can retract the brush back into the nozzle by further pressure on the trigger.

A feature of the DSV/Soot-Vac equipment is that the wire brush does not revolve during its passage of the tube. A revolving action would have the effect of packing the deposits on the walls of the flame tubes, whereas in this case the brush, which is of greater diameter than either the tube or the nozzle, effectively scrapes the tube walls clean in the course of only one forward and one return stroke.

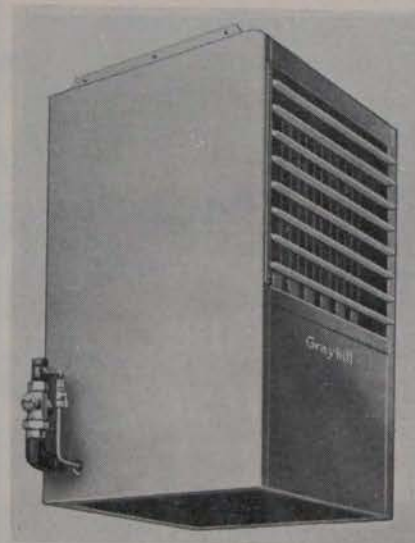

Additions to Grayhill space heater range

GRAYHILL Direct and Indirect Gas Fired Unit Heaters are the latest additions to the wide range of Grayhill space heater units. They are recognised as a most convenient and economical means of providing automatically controlled warmth in commercial and industrial buildings.

Installation costs are comparatively low as it is only necessary to suspend the heater and connect gas and electricity supplies.

Also new from Grayhill is a new range of "G" series oil-fired space heater units which have been developed as a result of many years' practical experience in the application of warm air heating.

Designed and styled by a leading industrial consultant, they are modern and attractive in appearance and finished in a smooth dust-free high bake enamel finish.

A specially developed positive displacement oil burner is incorporated and all controls are fully automatic in accordance with the latest British and European standards.

THE last twelve months have seen many new developments, additions and advancements to the Chrysler Airtemp applied machinery and systems range of equipment. The latest applied machinery and systems range brochure illustrates the comprehensive range of Chrysler-built central station equipment, currently available for fifty and sixty cycle electrical supply.

Save time, save money

World famous
CRITTALL
Fenestra
LOUVRES
can be fitted in jig time



CONTROLLED VENTILATION with attractive Crittall Louvres. Easy-action patent locking handle sets glass blades at any angle to suit the weather—fully open, or closed and locked against winter gales.

SIMPLE TO FIT. A screwdriver fixes the louvres and has them working perfectly in next to no time.

WIDE RANGE OF SIZES. Made in 13 standard heights from 1' to 6' 6" to take glass blades of any width up to 3'. Supplied to fit openings of almost any size

LOW COST. Crittall Louvres delivered direct, complete with glass blades cut to size.

BROOKS THOMAS & Co. Ltd.

4 SACKVILLE PLACE, DUBLIN 1. TEL: 41841



MONTHLY SPECIAL REVIEW

1

HEATERS (Electric surface, feed water, gas, immersion, oil, tubular).

TODAY'S HEATERS RANGE IS VERY EXTENSIVE

WITH modern research in our newly developed laboratories, the range of heaters produced to-day is very extensive. Present day developments and new techniques are simplifying our industrial mechanisation. To give but one example: A steam boiler over 30 years ago required to produce 1,000 lbs. of steam per hour occupied four times more space than a present day packaged job and took four to six times longer to produce the same amount of steam. This example can also be applied to heaters. The tendency is to make all units compact and neat and take up less space.

Electricity as a source of heat represents thermal energy in a refined form, easily applied to space heating which can be readily distributed and easily controlled. The accuracy of control, responsiveness, safety and cleanliness of electricity tends to carry greater weight in choice of method than operating costs and initial investment. Electric heat, no doubt, is more expensive on a direct heat equivalent basis than heat from conventional fuels. Of course, the added attraction of electric heaters is their efficiency rating—nearly 100 per cent.

TO-DAY there are so many different types of electric heaters, space does not allow us such explanation, but to mention the different types and applications. The types of metals and alloys used in the electric elements themselves are so developed to-day, that renewals of elements and casings is less frequent than in previous years. The reason for this is again better materials and more precisely the specific material or element for the particular application.

The more common types of electric heaters in use to-day are:—

- (a) Convector with metallic resistors: These are made for floor or wall mounting recessed or surface types and are made with resistors of incandescent bare wire or lower

temperature wire or sheath elements. An inner liner or reflector is usually placed between resistors and casing to provide a secondary air passage promoting circulation and minimizing rear casing temperature. Part of the heat is distributed by convection and part by radiation. The proportion of each depends on the construction of the unit. The convector heater is available also with a fan for quicker heating.

- (b) UNIT ventilators: These are usually high wall mounting or ceiling types, fitted with electric elements of the metal sheath type with extended surface and are fan operated and are available up to 35 Kw., and larger again up to 150 Kw. Temperature control is achieved by control of the different elements in the heater.
- (c) Unit heaters: These units have a specially built in fan which circulates the air through the electric elements so providing warm air.
- (d) Resistor portable types with reflector: These units employ an incandescent wire or strip heater backed up by a reflector, as seen in the ordinary office or house of to-day.
- (e) Infra red heaters: Sectional focussing, trough type reflectors, are made with low temperature resistors or with metal sheath, quartz tube or quartz lamp elements, to be wall-mounted at high level or suspended from the ceiling.
- (f) Storage heaters: The modern storage heater is so developed that it

may, in years to come, be a household piece of furniture in every home. The principle of operation of the ordinary storage heater is that heater is switched automatically at night, when electricity is cheap, using off peak periods. During these hours heat is given off by the elements in the heater and stored in the special substance of the heater itself. Over the day the heater then gives out its heat.

The modern storage heater incorporates many refinements. The primary development is that heat stored from the heater during the night can be automatically controlled during the day. A booster fan is incorporated to provide "topping up" of heat during the day.

There are various outlet grills from the heater, so that the heat can be directed from any side of the storage heater. One storage heater may be fitted into a dividing wall between two rooms and the heat output controlled to each room as required. Input and output of these heaters can be selected manually or controlled automatically from a central point.

THE above-mentioned types can be also provided with one or more of the many types put together—e.g., convector/radiant heater.

Panel heating can be found in the ceilings, walls, to-day of a modern house and is to be preferred to the tubular type electric heater. It is not unusual to find floor heating in a house, but it is unusual to find electric carpets. The principle of the electric carpet is similar to that of the electric blanket. It may interest our readers to know that in America and other highly developed countries, that the glass in the windows is electrically heated to prevent windows frosting up, thus keeping out the cold.



This special Review article is by J. L. Fitzgerald, B.Sc.

Continued overleaf

Thirty-one

The Irish Plumbing and Heating Engineer.

SPECIAL REVIEW

from previous page

Pay particular attention to oil storage

Electric surface heaters: Electric carpets and electric blankets may be classed as electric surface heaters. In the oil industry electric surface heaters are largely used in the form of "electric heater tracer cables" to keep oil storage tanks, oil lines, etc., warm. Electric tracer cables are most essential items of boiler installation using oil over 900 sec. Visc. To obtain maximum efficiency from an oil burning system it is necessary to pay particular attention to storing, pumping and pre-heating of the oil if proper combustion is to occur in the furnace. The methods of heating heavy fuel oils are various. Common practice is to use electric tracer cables and steam tracer lines for the oil lines—a combined steam electric out-flow heater in the storage tank as well as steam coil in the tank, and a line heater of the steam electric type to the burner-head.

Electric surface heaters are not confined to oil heating alone—they are extensively used in the tar and bitumen industry, chocolate manufacture, pharmaceutical, dairy and many others.

WATER heaters can be divided into two main types: Immersion and Electrode. The Immersion type is that used in a domestic hot water cylinder where the electric elements are immersed in the water to raise the temperature. Immersion heaters are also used in the production of steam. Electrode heaters are generally used in industrial installations, since the Kw. loading is usually heavy. The Electrode system is used for raising large quantities of hot water, i.e., thermal storage for flats, institutions, etc., and for steam raising units. They vary in size from 6 Kw. up to 600 approx.

By way of summary the key or focal point in using electric heaters, no matter what kind, size, shape or make is proper automatic control, proper selection of equipment for particular requirements and, lastly, but not least, good care and maintenance for economical service.

Thirty-two

IN this equipment review
we take a look at new
developments in the fields
covered by this month's
special review. (All claims are
those of the manufacturers).

A COMPLETE range of Isotapes for maintaining temperatures in pipes carrying liquids of any type is manufactured by Isopad Ltd., Boreham Wood, Herts., England. They are suitable for a temperature range of minus 100 degrees C. (-150 degrees F.) to 800 degrees C. (1,500 degrees F.).

Type ITW general purpose tape—moisture proof, has a temperature range of -100 degrees C. to 200 degrees C. (-150 degrees F. to 390 degrees F.). The electrically insulated element has silicone rubber extruded over it making it moisture-proof: 9" terminations formed by heating element. Low resistance tails can be fitted to these and most other Isotapes 12" (30 cm.)—10/- surcharge or any other length at proportionate charge.

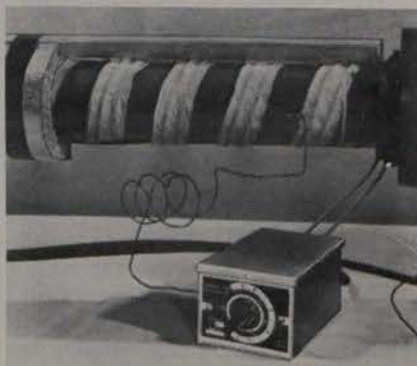

The type DH thermostat.

When controlling pipe lines to compensate for heat losses it is not advisable to control from the contents of the pipe. For this reason, standard surface thermostats have been developed. Isopad's Type DH, non-indicating thermostat with calibrated adjustable temperature scale, has a 10" long (250 mm.) control bulb fitted to the surface of the pipe line, and connected through a capillary (5ft. 8ft. long) to the control housing.

* * *

A PRODUCT of particular interest from Metway Electrical Industries Ltd., Canning St., Kemp Town, Brighton, is their Cosyway convector—

the newest addition to the firm's range. As a general purpose convector, the Cosyway is ideal, giving maximum effect at low running costs. A radiant element gives a glowing effect and indicates when the heater is on.

The Cosyway has a 750 watt loading AC/DC and consumes three units every four hours. A double skin body and internal deflector plate ensures safe surface temperature. The total weight is 8lbs., with top carrying handle. Other dimensions are: Body diameter, 5½"; overall height, 22½", with x 6ft. of 3-core flex. The convector is available in both the Republic and Northern Ireland.

THE SUNHOUSE "flame effect" is now available in the Vista Flame fires by H. Frost & Co. Ltd., Walsall. The "flames" are made of "gossamer," which is semi-transparent and yet highly reflective. They are kept in constant and varying motion by a silent and patented mechanism.

The Sunhouse Vista Flame 3 Kw. heater is fitted with three independently switched infra-red elements. The dimensions are 35½" wide, 22½" high, 8¼" deep, 11¼" at base. The Sunhouse "Warm-O-Lite" model 141 combined heat and light fitting is designed for ceiling mounting. The optically designed reflector houses a circular infra-red element, and a standard 100 watt. B.C. lamp provides illumination.

The range of Sunhouse heaters was introduced to the Republic market at the last Dublin Spring Show by Frost's associate company, Neasden Distributors Ltd., who will be pleased to welcome enquiries about the heaters. "Sunhouse" appliances have enjoyed very favourable business for quite some time now in Northern Ireland.

* * *

THE PARKRAY 77K solid fuel room heater, one of a new range of "open fire behind glass" appliances, provides room heating, hot water and central heating from the living room fire. The Parkray is from the range of Radiation Ltd., North Circular Rd., London. It has a new sharp, square-cut shape, projecting only 4½" from the surround. A ten position thermostatic control maintains an even burning rate according to the setting chosen. Models are also available with manual control instead of the thermostat.

Ascot Gas Heaters Ltd.—of the Radiation Group—have introduced the G.815 series balanced flue instantaneous multipoint gas water heater.

Continued page thirty-four

GAS

CENTRAL HEATING

●
*Architects,
Engineers,
Builders*

can now get up-to-the minute
TECHNICAL INFORMATION
at the new

GAS HEATING CENTRE

Dublin Gas Showrooms, D'Olier St.

Telephone 71811.

The Irish Plumbing and Heating Engineer.

SPECIAL REVIEW

from page thirty-two

(The Ascot G.715 series has now been withdrawn from manufacture). The G.815/2 is designed primarily for mains water supply, and the G.815/3 for low pressure supply. Both models are contained in a 7-inch deep white vitreous enamel outer case, and each is fitted with rotary gas control cock, integral volumetric gas governor, automatic valve and flame failure device. The Ascot 815 water heaters are available from gas undertakings and builders' merchants in Northern Ireland and from gas undertakings only in the Republic of Ireland. The "Parkray K" range is available in Northern Ireland only.

THE CLAYTON steam generator is an advanced design of compact steam raising plant—steam being available within five minutes of pressing the starting button, and has a thermal efficiency of 75—80 per cent. throughout the operating range. It is available with capacities ranging from 430 lbs. per hour to 5,000 lbs. per hour from 60 degrees F. working pressure up to 295 lbs. per sq. in.

The main components of the generator are the heating coil and combustion chamber, steam accumulator, water pumps, combustion system and electric controls. One electric motor drives the forced draught fan, the water pumps and fuel pump. The manufacturers are the English Electric Company, London.

* * *

MOUNTED high on the wall to save valuable floor space, the Radiation Central Heating Ltd., Ductair G2300 series gas-fired warm air central heating unit is contained in a compact, white-enamelled cabinet that measures only 23½" high, 32" wide, and 14½" deep. The heated air is fanned through concealed ducting and discharged through neat, skirting level grilles, providing full or background central heating in the smaller house, bungalow or flat.

The Radiation's Ductair G.3501 and G.4501 units are designed for two to four-bedroomed houses. They are identical in size and cover a wide range of outputs, from 30,000 to 35,000 B.t.u./hr. and 40,000 to 45,000 B.t.u./hr. respectively.

* * *

WILLIAM SUGG & Co. Ltd., Manor Royal, Crawley, Sussex, market an impressive range of Halcyon

gas-fired warm air heaters. The firm offers a choice of seven of these heaters which have been planned to suit all types of modern homes, and there are units specifically designed to provide whole-house, partial or selective heating.

The range includes the Halcyon Type F120/WH for whole house heating in a house of up to 1,750 sq. ft. superficial area. With a warm air output of 45,000 B.t.u./hr., and a gas rating of 120 cu. ft./hr. (500 c.v.) the dimensions of the unit are 50½" high, 16" wide, 20½" deep, including gas

controls for water circulator, when fitted, 28" depth, excluding flue spigots at rear, and 13" high—standard duct base—normally below floor level. Special depths are made to order.

The Halcyon Type F45—when used selectively, this heater will provide full comfort conditions in principal rooms of average exposure and construction up to 2,500 cu. ft. volume, or background heating in dwellings up to 1,500 sq. ft. superficial area. The warm air output is 17,000 B.t.u./hr., and the gas rating is 45 cu. ft./hr. (500 c.v.).

A FULL RANGE OF:—

- PUMPS ● CIRCULATORS
- PRESSURISING EQUIPMENT

● BOOSTERS

for:

HOT & COLD WATER SERVICES. HEATING SYSTEMS. INDUSTRIAL WATER SERVICES. FIRE FIGHTING.

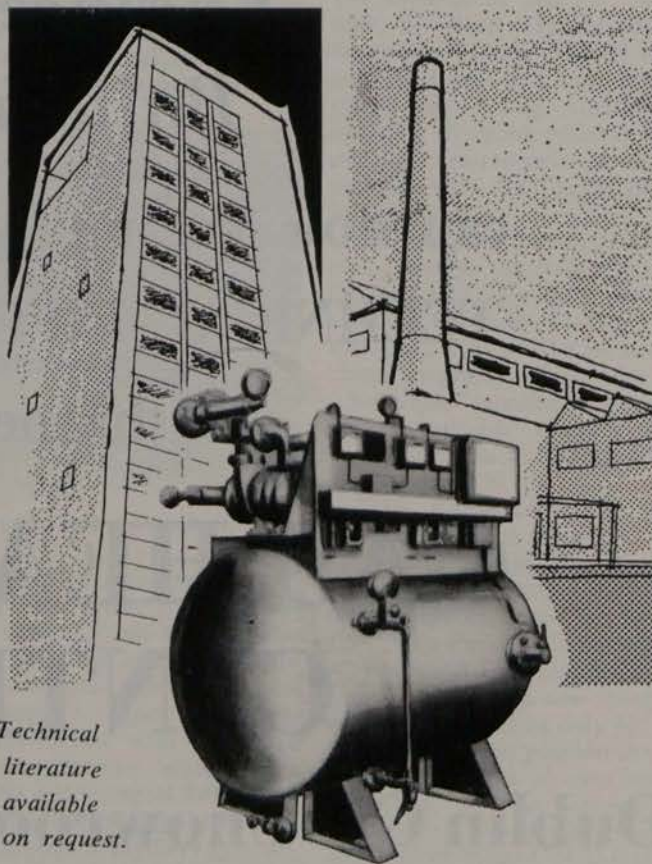

Technical literature available on request.

G. C. PILLINGER & CO. (IRELAND) LTD.
20 Sycamore Street, Dublin, 2, Eire. Tel.: Dublin 77007/8/9.

G. C. PILLINGER & CO. (IRELAND) LTD.
35 South Terrace, Cork, Eire. Tel.: Cork 23955.

MONSON and SONS
227 Beersbridge Road, Belfast, 5, Northern Ireland.
Tel.: Belfast 57823.

Thirty-four

SPECIAL REVIEW

from previous page

CARLILE & Co. Ltd., of Drury Street, Dublin, market their Hanovia Turboflo 803 inset fan heater for wall mounting, which employs the same tangential flow principle as a portable floor model. The casing of the unit is manufactured from stove enamel sheet metal, finished in two tones of neutral grey with a stainless steel trim.

There is a manually operated switch which provides a choice of 3, 2, or 1 Kw., and two speeds of cool air. As an optional extra, a built-in time switch giving up to 18 hours delay, can be provided. Provision is also made for the installation of these heaters with a separate room thermostat.

A safety cut-out is provided to prevent overheating in the event of accidental obstruction of the air flow. The unit is designed to give trouble free service and working parts are readily accessible from the front. This unit retails at 20 gns. and 25 gns. with a time switch. The Hanovia Turboflo Heater also comes in two portable floor models, the 321 Turboflo Major and the 210 Turboflo Minor—15 gns. and 13 gns., respectively, retail.

* * *

THE ECKO "Fanvector" fan-forced convector, providing powerful 3 Kw. convected heat, can also be used in summer time to circulate cool air. A thermostatic control maintains any desired temperature, even when running at low room temperature. It is finished in specially selected walnut veneer wooden cabinet and the dimensions are 15½" x 24" x 5½". The "Fanvector" is manufactured by the Echo Heating and Electrical Company Ltd., and the very comprehensive range of this Company's heaters may be obtained in this country through Kelly and Shiel Ltd., United Works, Dublin 3.

Kelly and Shiel Ltd. also handle the range of heaters available from Morphy-Richards (Cray) Ltd., Pall Mall, London.

* * *

A SUPPLY of a continuous flow of water at any exacting temperature, from cold to very hot (167 degrees F.) will be given by the "Crownette" automatic continuous water heater which is manufactured by P. and R. Electrical (London) Ltd., and distributed in this country by Roper Brothers Ltd., South Anne St., Dublin.

At 60 degrees C. or 140 degrees F.,

the "Crownette" has the remarkable flow rate of approximately 15 gallons per hour.

* * *

THE NEW Santon Over-Sink D18 automatic electric water heater is designed for use on all water pressures. The cylindrical inner container is constructed from cold rolled copper sheet with all seams lapped and brazed and tested to 50 lbs. p.s.i. It is then coated with a heavy deposit of pure tin to ensure the water is suitable for drinking and all other domestic purposes.

The heater plate, which is rotatable,

gives facilities for right or left hand fixing. Extremely fast recovery is achieved with the Santon removable 3 Kw. element. High thermal efficiency, with resultant low losses of less than 1 unit in 24 hours is achieved with special resin bonded fibre insulation. An additional safety feature is the new unique cord grip introduced with the D.18. The manufacturers, Santon Ltd., Somerton Works, Newport, Mon., in Wales, produce a vast range of water and electrical heating equipment. Agents: Chas. Nolan & Co., Parker Hill, Lower Rathmines Road, Dublin 6.



WITHOUT THIS

22 MILLION PEOPLE WON'T WANT TO KNOW YOU

This Autumn, high impact, full colour press advertisements for Lincoln warm air central heating will be seen by over 22 million home conscious readers in journals like *Ideal Home*, *Homes and Gardens* and *Reader's Digest*. Lincoln installers will be making even bigger profits. Don't you want a share of the cake?

Installing Lincoln warm air makes sense. Lincoln Furnaces. Quality built to give trouble free installations. Bred in Canada's rigorous winters. Many unique features. For five years Lincoln have been warming British homes, so they really know about warm air.

Lincoln design service. When you are a Lincoln installer you just send the plans to Lincoln and they design the installations for you, free of charge. This saves you time and as everybody knows, time is money, so you win both ways.

The wide range of Lincoln Furnaces. The largest range of furnaces manufactured in the U.K. There is a Furnace for every installation. Lincoln ducting,

purpose made ducting for every job. So, if you think you measure up to our high standards and like working with a company that likes working, then you deserve a share of the cake. Write for full information on Lincoln Furnaces, or ask our representative to visit you.

Please send me fully illustrated literature.

Please arrange an appointment
Tick appropriate box

NAME _____

ADDRESS _____

Lincoln Furnaces Ltd.

Area Representative, J. Fleck Esq.,
12 Wynnland Road, Carmonney,
Newtown Abbey, Co. Antrim.

"Better heating pumps?"

they said -

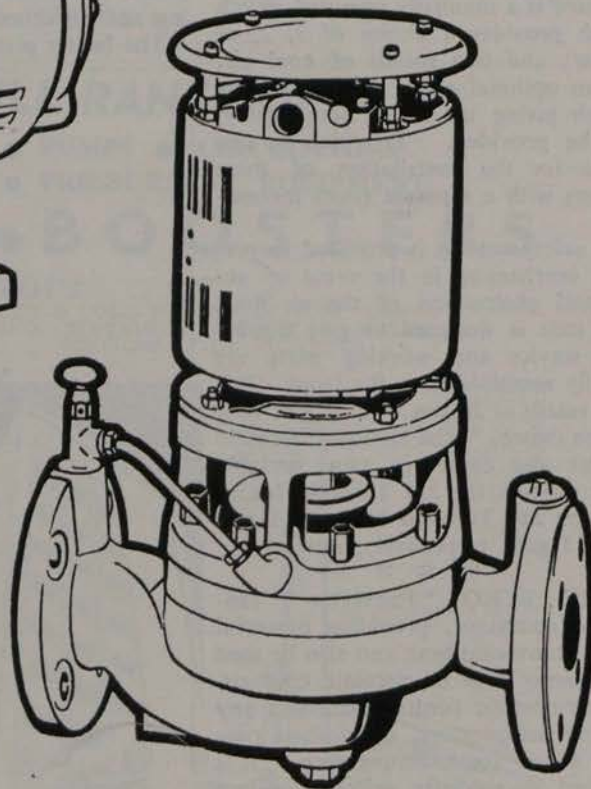
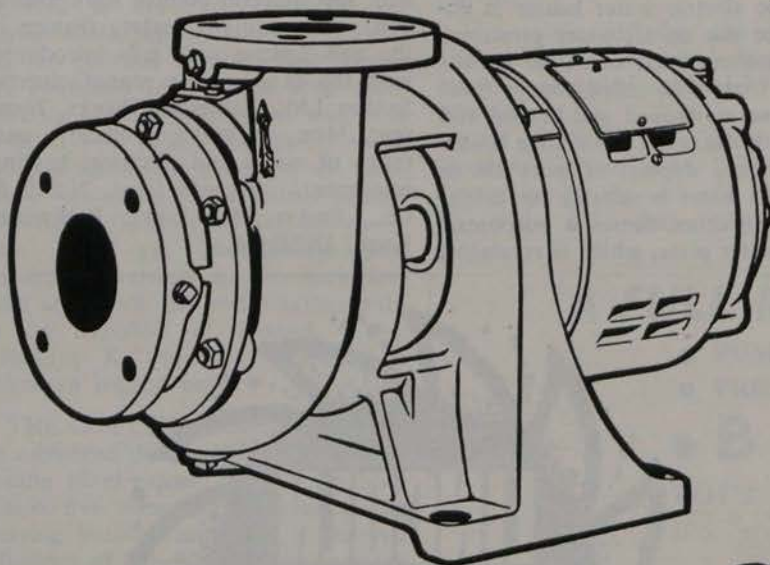

"Worthington-Simpson" they said

See our exhibit at The Building Centre of Ireland.



Worthington - Simpson Ltd
6 WATERLOO RD., DUBLIN.

Our hot water circulators and in-line accelerators promote efficiency in large heating systems. Economic operation is ensured by low running costs, simple installation and minimum maintenance. The range of circulators extends to capacities of 750 g.p.m. and heads up to 80 feet. The range of accelerators covers capacities up to 186 g.p.m. and heads up to 16 feet.

We invite you to write for leaflets 5184 and 5197 which give details of our heating pump ranges and also a guide to pump selection.

Pumps • Compressors • Heat Exchange Equipment

P0315



MONTHLY SPECIAL REVIEW

VALVES AND PUMPS

SELECT TYPE OF VALVE TO SUIT ITS PARTICULAR FUNCTION

THE selection of the right kind of valve is of great importance in order to obtain the best possible results. Since there is no "all purpose" valve the matter of correct selection involves consideration of the type of service required of the valve, the type of fluid and its temperature and pressure. How well a valve performs its function and how long it will last depends almost completely on how well its selected for its particular job.

The American Society of Mechanical Engineers Boiler Construction Code and the American Standard Code for pressure piping list temperature and pressure limitations for various materials of which valves and fittings are made. Similarly, the British Code of Practice follows the same principle.

As a guide to our readers the following will prove of interest. Generally speaking, brass should not be used for temperatures over 500°F. and iron for temperatures over 450°F. For higher temperatures and on services where working conditions are severe, such as in steam boilers, where acid is used, etc., stainless steel inserts should be used, or at least good quality steel.

Generally the following types of valves are in common use:—

(a) **Gate Valves.**—The flow characteristic of the gate valve is straight-way offering little resistance to flow, so minimising pressure drops. They are best for lines where unrestricted flow is required, such as pump suction lines or main supply lines. They are ideally suitable for top valve service where the gate is wide open or fully closed. They are not

suitable for throttling services, because fine regulation is almost impossible, for when the valve is throttled, the disc is subject to severe wire drawing erosion, and the gate valve is more difficult and costly to repair than a globe valve.

Gate valves are made with two types of disc design. The double or split disc type should be installed with the stem vertical and the hand wheel up to prevent jamming of the disc spreader mechanism. This type is good for non-condensing gas and liquid services at normal temperatures. Solid or wedge disc type can be installed in any position. It is best for steam use.

(b) **Globe Valves.**—The body design of a globe valve causes a change in direction of flow through the valve, thus increasing resistance to flow, but permits close regulation of flow. They are best suited for throttling services. Because the disc and seat can be quickly and conveniently removed for replacements or inspection, the globe valve is ideal for severe service where the valve is frequently operated. The globe valve is available with various types of seats. The composition disc type is satisfactory for medium pressure and temperature services on a wide variety of fluids and gases. This disc design allows quick replacement but is not satisfactory for throttling.

The conventional metal disc is excellent for average working conditions. It has a narrow seat bearing which allows easy regrinding. The plug disc type is best suited for the throttling, giving fine, accurate flow regulation. It is excellent for severe services such as high pressure drain connections, blowdown and boiler feed.

(c) **Angle Valves.**—The angle valve has the same operating and design characteristics as the globe valve. It

is used when making a 90° turn in the line and gives less restriction to flow than the globe valve and 90° elbow it replaces. It also reduces the number of pipe joints.

(d) **Check Valves.**—These are used to prevent back flow in lines and are often called non-return valves. Flow keeps the valve open since the flow pressure has to be greater to pen the valve than the back pressure. All check valves operate on one of two basic principles—swing or lift. The swing check valve, like a gate valve, has a straight-way flow characteristic. The lift check valve, like the globe valve, causes a change in the direction of the flow. Ordinarily the swing check valve is used with a gate valve, while the lift valve is used with a globe or angle valve.

PRODUCT REVIEW

—See Page Thirty-nine.

Immediate

Vacancy

An immediate vacancy exists for a Maintenance Engineer with a thorough knowledge of electrical control gear and electronics. Successful applicant would be required to service a well-known package boiler and to carry out electrical installations.

Attractive salary for this very interesting position.

TELEPHONE: 376061.

The Irish Plumbing and Heating Engineer.

EASY COMPACT INSTALLATION FOR WATER SUPPLY



Self-priming with a suction lift of 25 feet, the electric driven M range of Mono Pumps are compactly constructed, flange mounted to a motor of very low power consumption. Its silent operation permits installation in any convenient position and the non-pulsating, steady flow will not transmit noise through the pipeline. No oiling or greasing of the pumping element is required and no foot valve necessary.



The **MONO** pump

Attractive terms to Dealers

MONO PUMPS LIMITED, 31b CENTRAL HOTEL CHAMBERS, 7/9 DAME COURT, DUBLIN.
Telephone Number: Dublin 70843. MP251

ECI limited 19 Marlborough St., Dublin, 1.
(Tel: Dublin 49811) are the main selling agents
of the Belco Range of Thermostatic Mixing Valves
in Eire and Northern Ireland.

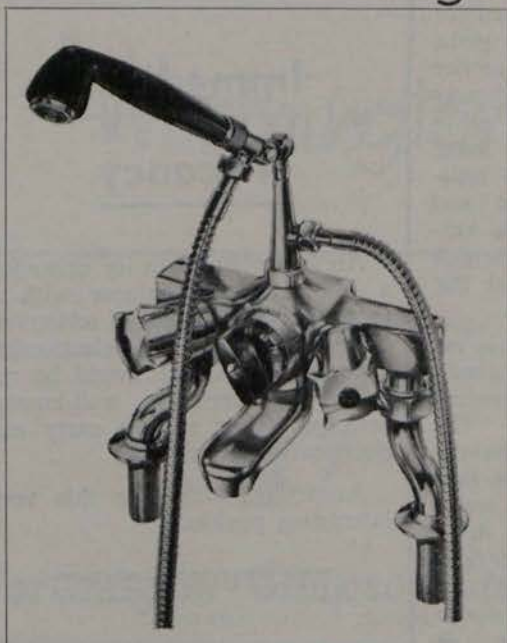

BELCOMIX 'CONSORT' Patent No. 903539 and 963226
Chromium plated, $\frac{3}{4}$ " 1010/53—the ideal Thermostatic
Mixer for domestic installation. The centrally mounted
fingertip control is directly calibrated in Fahrenheit, giving
quick, positive, temperature selection for maximum com-
fort and safety. The two stop-cocks with Stella headwork
provide independent control of the flow of water to bath
and/or shower—the pre-set temperature being automati-
cally maintained at all times.

Obtainable at all leading builders and plumbers merchants.
Fully descriptive leaflets available on request.



BELCO MANUFACTURING CO. LTD. · BELCO HOUSE,
PARK ROYAL ROAD, LONDON, N.W.10. Telephone: ELGar
2481. PBX. Grams & Cables: BELCONIA, LONDON, N.W.10.

A HEAVY duty "no-stick" motorised globe valve has been added to their line of hydronic zone controls by White-Rodgers, of Twickenham. It adapts to many applications in flow control of steam, water, oil or air. "Sticking" is eliminated, by use of a powerful lifetime-lubricated gear motor operator which opens the valve against rated line pressure, without limitations of pressure unbalance. When the valve is open, flow is unrestricted through the full area seat opening. The 25-volt motor is of the continuous duty type, of shaded pole design and is available with 32 second or 139 second timing cycle. Gears are machine cut hardened steel.

The motorised globe valves are designed to operate to a pressure capacity of 150 p.s.i. The gear motor operator of life-time lubricated. Both the operator and disc may be removed if desired, without taking the valve off the line. In emergency, the facility is provided to close the valve when failure has occurred in the open position and also to open the valve when failure has occurred in the closed position. A marked advantage in this valve is the automatic compensation for disc wear provided as the valve continually reseats itself. This assures positive shut-off indefinitely. The company also manufacture a series of motorised zone valves. The "Zone-a-Flow" Valve is available in five models from $\frac{1}{4}$ " to $1\frac{1}{4}$ " with either solder or screwed iron connections.

* * *

CROSBY VALVE and Engineering Company have announced the introduction of a completely new Mason-eilan single seat heavy duty globe valve body having exceptional flexibility of application. Extra top heavy guiding of the plug eliminates the need for orthodox bottom guiding, reducing turbulent flow and trouble due to any solid particles which may be in suspension.

Careful attention to body and port design to give streamline flow, plus the elimination of the bottom guide, permits a greater rate of flow through a given seat diameter. These flow engineering features enable the new 20,000 series valves to have a much greater CV or flow capacity, the capacity being approximately equal to that of the equivalent line size double seat control valve.

The 20,000 series of valves are available screwed $\frac{3}{4}$ "—2" with trim sizes $\frac{1}{4}$ ", $\frac{3}{8}$ ", $\frac{1}{2}$ ", $\frac{3}{4}$ ", $1\frac{1}{2}$ ", and 2"; Flanges— $\frac{3}{4}$ "—10" with not less than four trim sizes for each line size valve. Standard materials are carbon steel body

IN this equipment review
we take a look at new
developments in the fields
covered by this special review.
(All claims are those of the
manufacturers).

and stainless steel trim. Other materials are available to order. Luke, Martyn & Co. Ltd., 1 Sandyhill Park, Drumbeg, Dunmurry, Belfast, are the Irish agents.

* * *
MESSRS, LUKE, MARTYN have also advised us of the Kosmos Temperature Regulator for they are agents. It can be supplied to control temperatures between 20 degrees C to plus 300 degrees C. (- 4 degrees F to plus 572 degrees F), with an adjustable range of plus or minus 40 degrees C of the customer's specified setting.

The Kosmos regulator can be supplied with either a closing or opening valve. The closing valve maintains accurate control by automatically shutting of the heat supply when the pre-set temperature at the bulb has

Continued overleaf

The Centrifugal **MOPUMP** for General Service

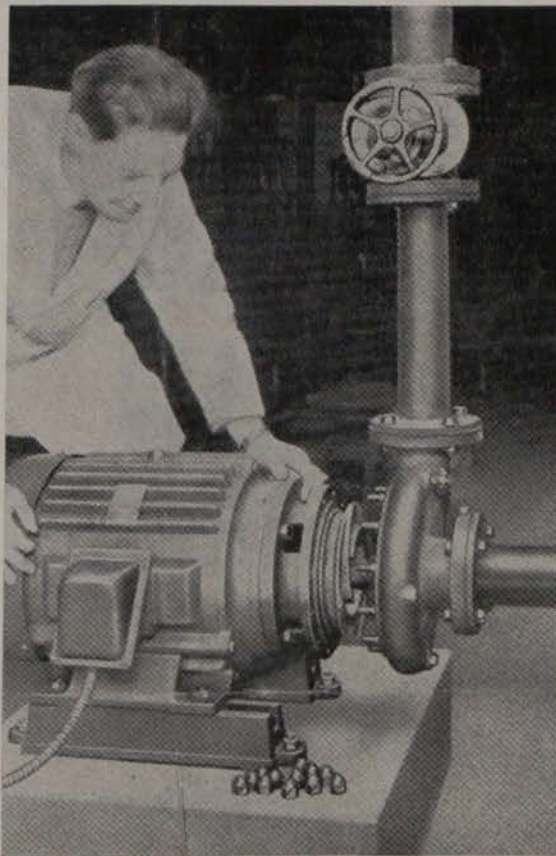

This model G.S. Mopump is, as the name implies, suitable for a wide variety of duties handling water and other liquids.

The unit construction G.S. Mopump illustrated here offers some remarkable installation advantages.

'MOPUMP'

is the trade name for Centrifugal Pumps manufactured by Rhodes, Brydon & Youatt (Division of Crane Ltd.).

For technical information, catalogues, etc., contact
Associate Company:

TYLORS OF IRELAND LTD.

55 Rathgar Ave., Dublin, 6. Tel.: 904603/4. Grams: 'Tyland, Dublin'.
Belfast Office: CRANE LTD., Mulhouse Lane, Belfast, 12.
Telephone: 32388. Grams: "Cranelon, Belfast".

Thirty-nine

The Irish Plumbing and Heating Engineer.

been reached, while the opening valve maintains accurate control by passing a coolant when the pre-set temperature at the bulb is reached.

* * *

A COMPLETE range of pumps, catering for the needs of modern heating, ventilating and air conditioning installations is offered by Worthington-Simpson Ltd., Newark, Notts. Of special interest are the types DH and DFH hot water circulators designed to ensure economic operation and to promote efficiency in large heating system. These ranges cover capacities up to 750 g.p.m. and heads up to 80 feet.

The maximum temperature is 300 degrees F and oil lubricated sleeve bearings are used for quiet operation. Sealing arrangements may be high temperature packing or mechanical seal. Motors for "Monobloc" units—type DFH, may be of totally enclosed or drip-proof type with fixing dimensions to B.S.2960, part 1 and part 2; electrical performance to B.S.

PRODUCT REVIEW

from previous page

2613/1957. All insulation is to class "E" specification.

Worthington-Simpson's In-Line Accelerators—type DA, are designed to ensure reliability and provide continuity of flow in hot water systems throughout the winter months. Maintenance is simplified—removal of motor carries away all working parts, and pipe connections are undisturbed. Special long-life carbon is used in the mechanical seal. The capacities are up to 150 g.p.m. and heads up to 15 feet. The maximum temperature is 250 degrees F., and the maximum pressure is 100 p.s.i.

* * *

A NEW development in water guns which are trigger operated and incorporate an automatic shut-off has been announced by Meynell & Sons Ltd., of Montrose Street, Wolverhampton.



A motorised valve from the Thermocontrol range.

The new maximum working pressure of the "Automatic Water-Saver Spray Nozzle" is now up to 400 p.s.i., and the spraygun can be supplied with adaptors for ½", ¾", or 1" hosepipes or a fire brigade adaptor if required.

Also new from Meynell is the "Best-heat" Thermostatic Radiator Valve which may be fitted to any standard central heating system and the setting of the control knob is by a colour code—blue, cold; yellow, tepid; and red, hot, which is clearly visible by means of prismatic refraction. Only one "Bestheat" is required for each radiator and it must be fitted at the bottom of the radiator.

In addition to their range of heavier gate and glob valves, Meynell have produced a light-pattern gate valve to be known as the Meynell Fig. 2X. It has been tested to 300 p.s.i. (hydraulic), and is claimed to be suitable for saturated S.W.P. at 125 p.s.i. and cold water, oil, or gas, at 200 p.s.i. Sizes ranging from ½" to 3", include ½", ¾", and 1" valves suitable for copper-to-copper connections. The distributors in the Republic of Ireland are Brent Chemical Products Ltd., 117-118 Cork St., Dublin, and in Northern Ireland, Mr. C. G. Williamson, 21 Mayfair, Arthur Square, Belfast 1.

* * *

A THREE-WAY mixing and diverting valve for medium size domestic size installations has recently been introduced by Koswa Ltd., of Alton, Hants., who are represented in Ireland by Mr. H. C. Maguire, 13 Fitzwilliam Square, Dublin.

The valve—the IWK three-way valve



PUMPS for heating installations of all sizes



Heating engineers find, in the range of Safran Pumps, units exactly adapted to their purpose whether it be for m a m o t h office block, country mansion or two bedroom bungalow systems.

S.C.E. Self contained Electric Sets for horizontal or vertical installation. 14 sizes, duties up to 1,800 g.p.m.

C.C.E. Circulators, Fullway direct-in-pipeline type, 8 sizes, duties up to 300 g.p.m.

SAFRAX C.S.E.G. Circulators. Silent, glandless units for small-bore systems. 4 sizes, duties up to 16 g.p.m.

Distributors in Eire and Northern Ireland:

British Steam Specialties Ltd.

33 Leeson Park,
DUBLIN, 6.

Distillery Street,
BELFAST, 12

SAUNDERS VALVE COMPANY LIMITED

Safran Pump Division

DRAYTON STREET, WOLVERHAMPTON. Phone: 25531.

Forty

750—consists of two coupled valves, in a common iron casing, valve (b) opening with increase in temperature and valve (e) closing with increase in temperature. Both valves operate proportionally, giving a full bore characteristic.

The valve may be used either with self-acting thermostats for straight-forward mixing or compensated heating installations, or with control motor E 3200 for electrical operation. The valve is only to be used with a relatively low differential pressure between inlet and outlet. For higher duties and pressure differences, valve type 770, with pressure-balanced valves, should be used.

* * *

THE RANGE of Satchwell valves includes many sizes and types suitable for on-off, modulating or three-way control, but the recent introduction of the Satchwell "Minival" will be of interest to engineers concerned with both domestic and industrial installations.

The Minival is an on-off motorised control valve designed to control the flow of low pressure hot or cold water, particularly in central heating or air conditioning applications. It is capable of being mounted in any convenient position or attitude, and has been designed so that the amount of water that can pass the closed butterfly is a minimum.

The high quality brass body is available in $\frac{1}{2}$ ", $\frac{3}{4}$ ", and 1" BSP sizes, the $\frac{1}{2}$ " and $\frac{3}{4}$ " being supplied with copper compression adaptors. The motor, packed separately, is of very low consumption (4 VA at 200-250 volt a.c.), and suited to control by a timeswitch or Satchwell TL25, SA 36 or FP thermostats. Satchwell Controls Ltd. are at Slough, Bucks., England.

* * *

HATTERSLEY'S Delflo radiator valves have been designed for use on all low and medium pressure hot water systems up to 150 p.s.i., and 250 degrees F. All sizes $\frac{1}{8}$ " to $1\frac{1}{4}$ " are full bore-streamlined and have minimum flow resistance, making them ideally suitable for either pumped or gravity systems. The Delflo radiator valves have wheels and lockshields in ivory coloured Delrin—a thermoplastic material chosen for its outstanding qualities of exceptional strength and toughness, stain resistance and pleasing translucent appearance.

Hattersleys, who are at Ormskirk, Lancashire, have also produced improved and restyled central heating

PRODUCT REVIEW

from previous page

regulator incorporating an enlarged range of sizes to fulfil the requirements of general heating work in addition to domestic central heating installations, and with a working pressure of 150 ft. head at 200 degrees F.

* * *

THE RANGE of equipment that can be offered by Girdlestone Pumps covers all likely Condensate Return requirement of steam users from the largest industrial concerns to the small hospital. For the smaller requirements a range of standard packaged units or equipment with separate receiver and pumps are available.

Included in this range are receivers of galvanised steel or copper with single or duplicate pumps and all with automatic controls. Girdlestone Pumps have for many years specialised in the design and manufacture of Automatic Condensate Return Equipment to exactly suit the customer's requirements, and have in fact manufactured packaged units with receiving tanks as large as 2,000 gallons.

Girdlestone Pumps are represented in the Republic of Ireland by W. Finucane and Co. Ltd., Upper Pembroke Street, Dublin, and in Northern Ireland by Mr. C. G. Williamson, 21 Mayfair, Arthur Square, Belfast.

* * *

RETAINING the operational features of the standard Economiser, the new range of sizes offered by The Worcester Valve Co. Ltd (Victoria Road, Burgess Hill, Sussex) provides a new concept of piping flexibility. In addition, field maintenance can be accomplished in minutes and at a fraction of the cost of other types of valves.

Removal from the line is accomplished easily by simply removing four nuts and bolts and dropping the valve from the line flanges, and separating the sections. Seats and seals can be replaced readily, bringing the valve back into operation in minutes.

Economical to buy, cheap and quick to service, this valve can be reconditioned in four minutes. It is available in stainless and carbon steels, Nodular Iron, bronze and aluminium, with special materials of construction if required.

Kosangas for modern heating

The versatility of Kosangas as a fuel is never better demonstrated than when it comes to heating. A very wide variety of heaters is available. Kosangas burns absolutely cleanly, fume-free, and leaves NO deposits in combustion chambers, heat exchangers or flues. Kosangas is non-toxic and sulphur free as well. Its high calorific value per cubic foot (2,500 BTU) calls for small pipes only and makes for neat installations.

For Domestic work—boilers, warm air heaters, balanced flue heaters (flued, but no chimney required, up to 37,000 B.T.U. per hour; easy installation), fireplace type room heaters (flued), fixed, portable and self-contained radiant and convector heaters.

For Commercial and Industrial Work—all the heaters above, and suspended unit heaters, radiant heaters (fixed or portable up to 75,000 B.T.U. per hour per unit), and portable high capacity hot air blowers and convector heaters.

Kosangas installations are backed by a country-wide Service Organisation.



● Pictured is one of the certificate winners — James Conway, Northbrook Ave., North Strand, Dublin—receiving the presentation from Mr. A. P. Cooney, Chairman of the Institute of Mechanical Engineers.



THOMAS Potterton Limited announce various output and price changes in their commercial and industrial boilers and their BOA domestic oil-fired units. The rated outputs of the BOA and EOA boilers have been increased by design modifications to the burner units, based on experience gained in France with the Potterton subsidiary, Dieny Lucas et Potterton S.A. Although the total price of these boilers has been marginally increased with the up-rated output the price per 1,000 B.t.u./hr. has been reduced. For instance, in the case of the BOA boilers, outputs have been increased by 13 per cent. while prices have been raised by only 2 per cent.

In some cases small price increases have been made for certain commercial and industrial boilers, namely, the "G" series and Rex 3 gas-fired units and DOA and FOA oil-fired boilers. The prices of the Diplomat 100, 150, 200, and 250 range have also been increased by 3 per cent.

WINNING WELDERS

AS conditions of contract and requirements of insurance companies would in future specify that welding in most projects would have to be carried out by certified welders, it was essential that as many welders as possible should obtain certificates, said Mr. William Cronin, Chairman, Irish Welding Association, at the presentation of certificates to 21 young welders at the Building Centre.

Since the scheme of awarding certificates was started in this country in 1962 it had met with remarkable success, said Mr. Cronin, and it was now no longer necessary for a welder to go to another country to get a recognised certificate in welding.

COLUMBIA

CT Steam Boilers

Tubeless — packaged 3 pass design, fully automatic, 85% efficient, sizes from 170lbs. to 900lbs./hr. Pressures up to 125 p.s.i.

Hot Water Boilers

Packaged — Columbia, sizes from 87,000 B.T.U.'s-100,000 B.T.U.'s. The only boiler with 10 years manufacturer's guarantee.

Powermaster Packaged Boilers

FULLY AUTOMATIC, SUITABLE FOR ALL GRADES OF OIL, MANY MODELS TO CHOOSE FROM. SIZES AVAILABLE FROM 20 H.P. UP TO 600 H.P. STEAM AND HOT WATER.

★ Now over 350 Powermaster Boilers operating in this country with over 50 repeat orders. Our after sales service is unbeatable for spares and service, which operates around the clock.

HENDRON BROS. (Machinery) LTD.

144 RICHMOND ROAD, DUBLIN, 3. TELEPHONE 376061

Thanks for Asking...



Yes, we have almost every size of cast iron heating boiler you need . . . in stock . . .

and STEEL COLUMN RADIATORS, too

(phone Jimmy – he can maybe get them out same day) in all sizes and number of sections.

Telephone: 693940 and 693943.

Telegrams: Quadrant, Dublin.

QUADRANT ENGINEERS

167 STRAND ROAD, MERRION GATES, SANDYMOUNT, DUBLIN 4.



Sole Agents for BUDERUS Boilers and Radiators

CLYDE

LIGHT OIL BURNERS



Clyde Fuel Systems manufacture a wide range of light oil burners for converting boilers from solid fuel. Illustrated is model 'Junior' which can be easily and quickly installed.

6 BRANCHES THROUGHOUT IRELAND



You can now take advantage of six service branches in Ireland. Another addition to the extensive after sales network throughout Ireland.

CLYDE tasso

CAST IRON SECTIONAL BOILERS

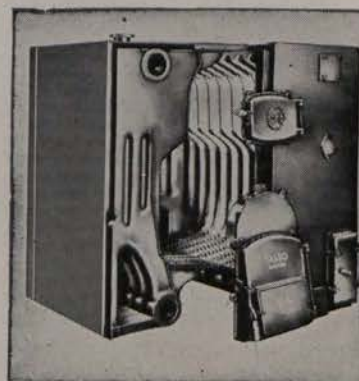

Clyde "TASSO" cast-iron sectional boilers are available for solid fuel, oil, or mechanical stoker firing with operating efficiencies of approximately 80%. Suitable for central heating and hot water systems with ratings from 60,000 to 2,575,000 B.T.U.'s per hour.

CLYDE FUEL SYSTEMS LTD.

80 Holywood Road, Belfast. Tel.: Belfast 65365/6.

Branch at Londonderry.

CLYDE FUEL SYSTEMS (IRELAND) LTD.

6 Mount Crescent, Dublin. Tel.: Dublin 66489.

Branches at Cork, Limerick and Longford.

Forty-three

The Irish Plumbing and Heating Engineer.

in brief...

● NOW that the extension to their works at Wembley has been completed RCM (Air Distribution) Limited will close their Great Portland Street offices and will be operating from RCM Works, South Way, Wembley, Middlesex.

* * *

● WE ARE informed that Mr. F. M. Mara, 6 Herbert Place, Dublin, 2, is the Representative for the Republic of Ireland for the Comploflex Co. Ltd., not Mr. G. A. Reid, as quoted in an entry under "Hose" on Page 59 of our June, 1965, Directory.

* * *

● PAN-AER Sales Ltd., 12 Lower Mount Street, Dublin, 2, have been appointed agents in the Republic of Ireland for the London Fan and Motor Co. Ltd., manufacturers of the "Breeza" range of industrial fans.

DESIGN

from page twenty-one.

bays or delivery intake points through which the effect of the heating is constantly being nullified. The provision of insulated roofing and double doors to the bays would not only make the building easier to heat but would possibly reduce the installation costs of the heating and certainly reduce fuel costs

All the problems which have been used to illustrate the point of discussion are inevitably settled before the final working plans are prepared, but only after much time has been wasted by both the consulting engineer's staff and the design staff in ironing out the points. Drawings are prepared, scrapped, re-drawn and all this could be avoided if, as said in the opening paragraphs, the consulting engineer or heating contractor were invited to join those preparing the early sketch plans.

Finally, the mechanical services of any unit are in their own way just as important as the decor, finish and furnishings, and are just as worthy of as much consideration when preparing a scheme and specification. If this is done it will only result in the client receiving a building free from the many idiosyncrasies which so often appear.

Forty-four

OIL VICTORY AT BALLYMUN

OIL has emerged the victor in the big Oil v. Solid Fuel struggle for the heating of the 2,600 flat Ballymun system-built housing project.

Despite strong moves for a favourable decision for home produced fuel—anthracite or turf—the Dublin City Council, meeting as a committee of the whole house, decided on oil firing.

It was stated that the cost of installing a solid fuel system would be £100,000 more than the cost of a

plant using oil.

A proposal from the oil companies that they should build and supply the equipment for the boilerhouse was turned down. It was thought unwise to give such control to an organisation outside the Corporation.

Instead, the Corporation will build the boilerhouse so that it can be converted to solid fuel firing if necessary.

Of 400 houses in the project 120 are to be centrally heated by gas.

*Andrews - Weatherfoil (Ireland) Ltd.,
and Tedcastle - McCormick & Co. Ltd.,
have pleasure in announcing the
formation of -*

**Andrews - Weatherfoil
(Ireland) Ltd.,**

*who will offer full heating, ventilating and
air conditioning services from their new
Dublin office at -*

6, WESTMORELAND STREET, DUBLIN, 2

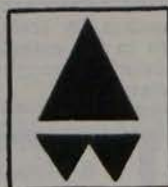

Telephone
73871



WATER STORAGE

the
ASBESTOS
way

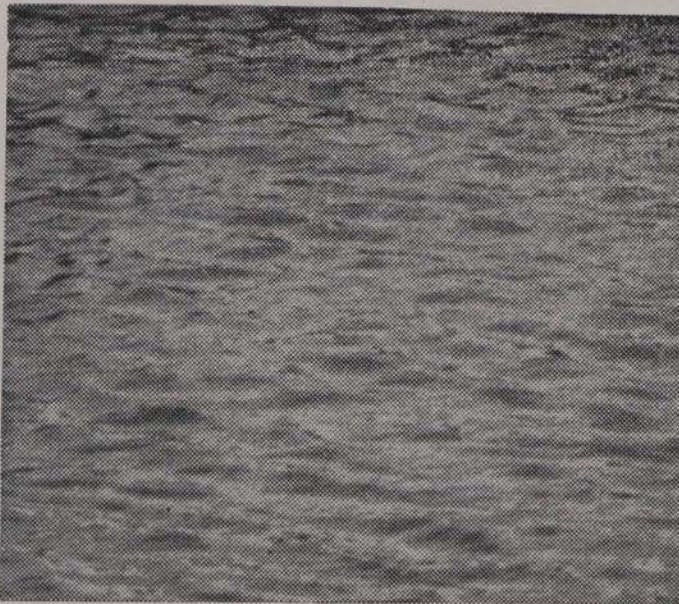

No water storage problems
if you instal Asbestos
Cement tanks. Strong,
light and economically
priced Asbestos Cement
tanks cannot rust
or corrode and
require no maintenance.

For details, write today!

ASBESTOS CEMENT LIMITED

19 Lr. Pembroke St., Dublin 2.



Asbestos

Grosvenor

Published by Irish Trade and Technical Publications Ltd., Callaghan Chambers, 13-15 Dame St., Dublin, 2.
Printed by The Greyhound and Sporting Press Ltd., Davis Road, Clonmel.

Some like it

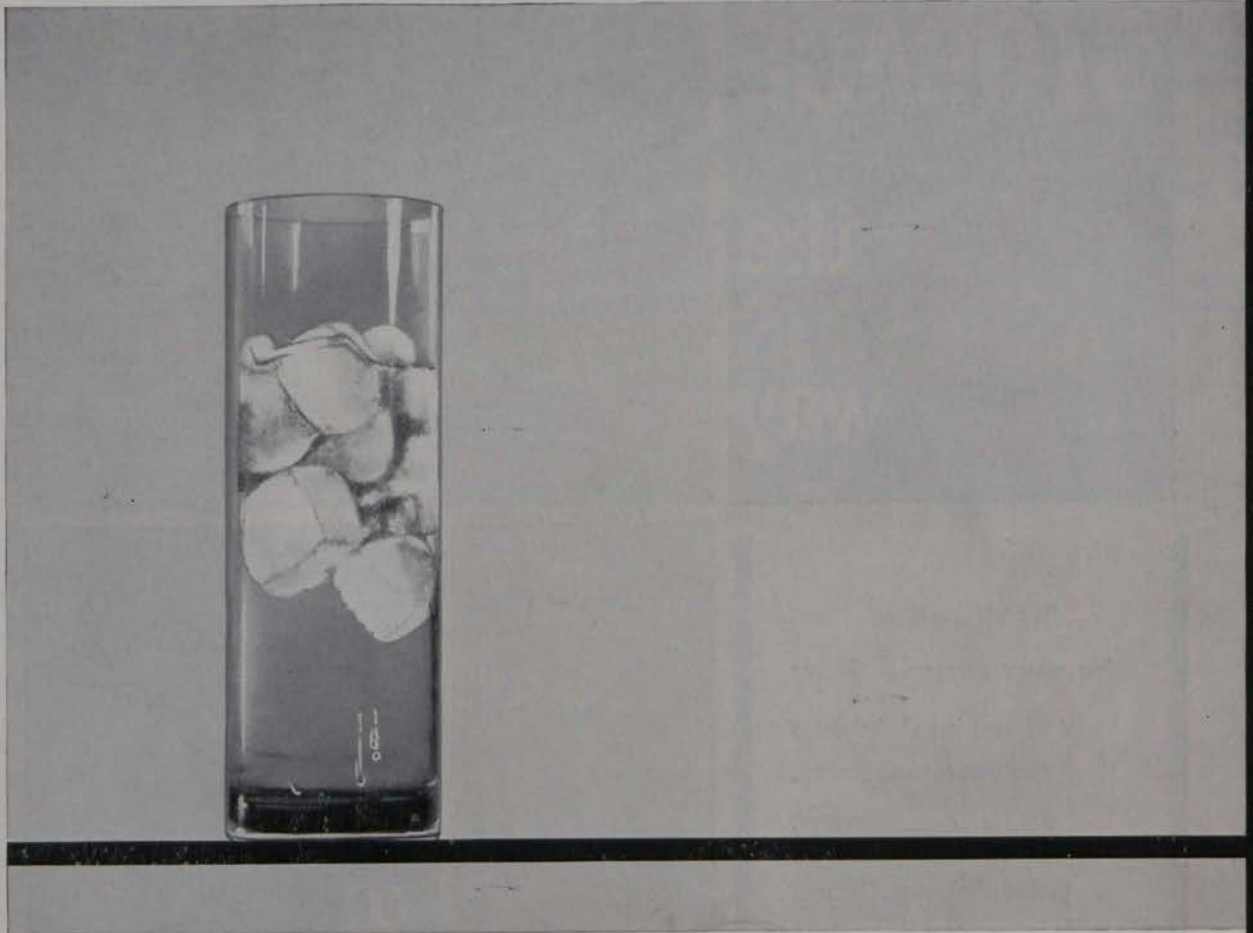

*. . . cool in one part of the house and warm in another. You can give it to them just the way they want it with Satchwell Zone Control. One of the new Minival motorised valves plus a Satchwell TL thermostat costs **less than £10.***

*Obtainable from stockists throughout the country, the Minival is available in $\frac{1}{2}$ in., $\frac{3}{4}$ in. and 1in. B.S.P. sizes—compression fittings for copper pipes are supplied with smaller sizes. **For full details***

Write for Leaflet P.37 to:-



SATCHWELL CONTROL SYSTEMS LIMITED
Slough, Bucks. Tel: Slough 23967  A Member of the Elliott-Automation Group