

1-1-1965

The Irish Plumbing and Heating Engineer, January 1965 (complete issue)

Follow this and additional works at: <https://arrow.tudublin.ie/bsn>

 Part of the [Civil Engineering Commons](#), [Construction Engineering Commons](#), and the [Construction Engineering and Management Commons](#)

Recommended Citation

(1965) "The Irish Plumbing and Heating Engineer, January 1965 (complete issue)," *Building Services Engineering*: Vol. 4: Iss. 10, Article 1.

doi:10.21427/D72D9C

Available at: <https://arrow.tudublin.ie/bsn/vol4/iss10/1>

This Article is brought to you for free and open access by the Journals at ARROW@TU Dublin. It has been accepted for inclusion in Building Services Engineering by an authorized editor of ARROW@TU Dublin. For more information, please contact arrow.admin@tudublin.ie, aisling.coyne@tudublin.ie, vera.kilshaw@tudublin.ie.

ENGINEER



The British Steam Specialties Ltd

supply heating and pipeline equipment for factories, stores, offices and public buildings

B.S.S. Ltd. can supply complete equipment for heating installations and all ancillary equipment for steam, water, gas, oil and compressed air pipelines.

B.S.S. Ltd. have large stocks available from branches at Dublin and Belfast

B.S.S. Ltd. hold stocks of Copperad Corinthian Pressed Steel Radiators in Dublin.

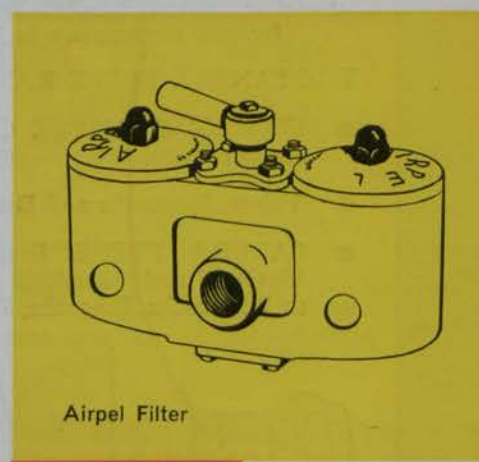

Airpel Filter



Copperad Fan Convectors



Vee-Reg Valves

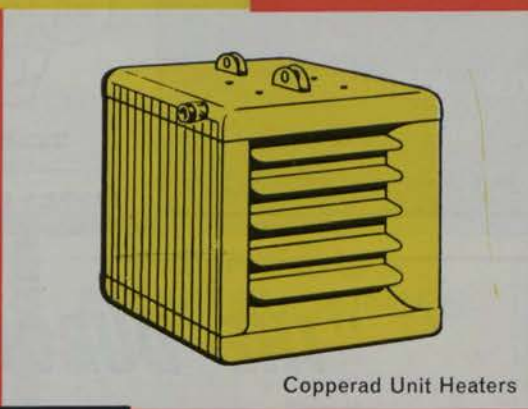

Copperad Unit Heaters



DUBLIN
33 Leeson Park
Dublin, 6
Dublin 66961-2-3-4
Telex 317

BELFAST
Distillery Street
Belfast, 12 ☉
Belfast 28031 (3 lines)
Telex 74561

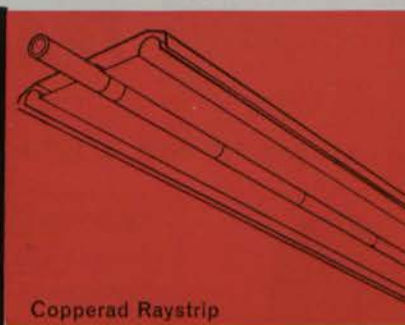

Copperad Raystrip

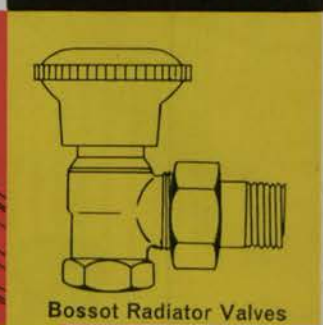

Bossot Radiator Valves

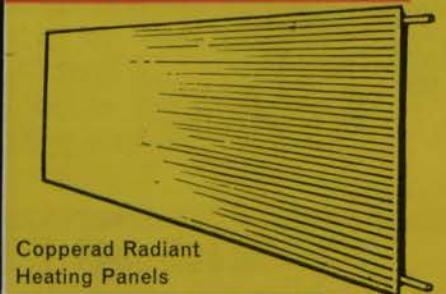

Copperad Radiant Heating Panels



Velan Steam Traps

January 1965

Published by ARROW@TU Dublin, 1964
Vol. 4 No. 10

SPECIAL MONTHLY SUPPLEMENTS: NORTHERN IRELAND SECTION
INDUSTRIAL HEATING & VENTILATING IN IRELAND

on the site, Plumbers fit . . .

the first choice **Sanbra Fyffe**



'SETFLO' RADIATOR VALVE

PLUMBERS' BRASSWARE, TAPS & FITTINGS

for ALL requirements in Plumbing and Heating Services.

THE SANBRA FYFFE RANGE INCLUDES:—

- CONEX-INSTANTOR Compression Joints and Fittings for Copper Tube.
- Valves, Stopcocks and Drawn Copper Traps.
- SANBRA FYFFE Brassware — including the renowned 'Easilyne' and 'Aqualyne' Luxury Taps and Fittings — as well as Pillarcocks, Bibcocks, Wastes, Plugcocks, etc.

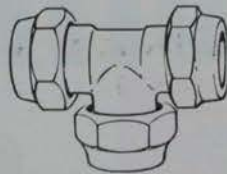

TEE-PIECE.



'Aqualyne' Highnecked Pillarcock

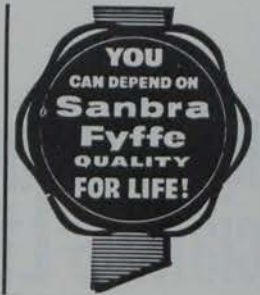

SANBRA FYFFE LTD., CONEX WORKS, SANTRY AVE., DUBLIN, 9.
Telephone: Dublin 375131 (5 lines). Telegrams: Sanbra, Dublin. Telex 5325.

A NEW
PRODUCT

"THE DUBOIS PLASTIC TRAP" (Regd.)

A NEW
PRODUCT

Provn. Pat. No. 38070/60.

1 1/4" and 1 1/2" diam. x 1 1/2" seal "S" and "P" BLACK HIGH DENSITY PLASTIC TRAPS

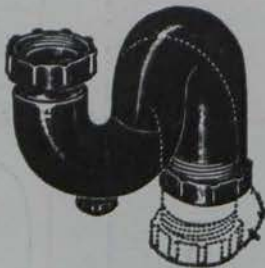

Orthodox Shape!
Smooth Bore Tubular construction.
Outlets can be turned through 220°.
A two-piece trap at a one-piece price.
Outlet on 'S' trap turned to inlet forms a through-bore bottle trap.
Frost and damage resisting.
Light weight = lower transportation costs.







Manufactured by:—

THE DU BOIS COMPANY LIMITED
15 Britannia Street, London, W.C.1

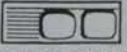
WHATEVER SIZE & TYPE OF SINK YOU WANT **FISHOLOW** MAKE IT!

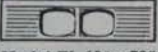
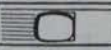
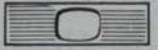
STAINLESS STEEL MULTI-FLUTED SINKS

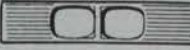
 Model L 18" x 36" £12.0.0. Model W 21" x 42" £15.0.0.	 Model DL 18" x 54" £21.0.0.	 Model N 18" x 42" £13.5.0.	 Model TL 18" x 72" £25.10.0. Model TW 21" x 84" £31.0.0.
 Model WL 18" x 54" £17.10.0. Model WW 21" x 63" £20.10.0.	 Model DN 18" x 63" £18.0.0. Model DW 21" x 63" £19.10.0.	 Model WN 18" x 63" £19.0.0.	 Model TN 18" x 84" £28.0.0.

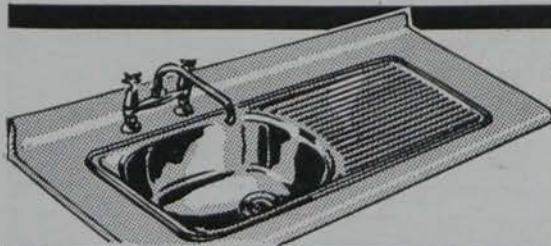
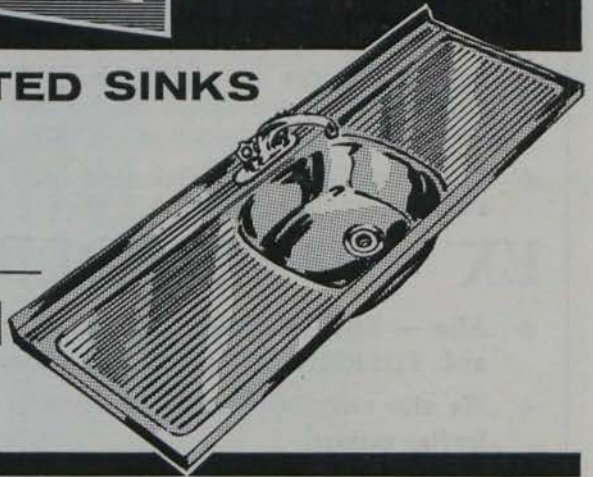

STAINLESS STEEL INSET SINKS



Model FL
16½" x 36" x 7" deep
£15.10.0.



Model FDL
16½" x 54" x 7" deep
£25.0.0.



STAINLESS STEEL BOWLS



Model XIX 16½" x 45½"
£32.0.0.

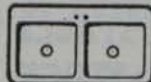

Model WXX 21" x 31"
£15.15.0.

Model WZZ 17½" x 35½"
£18.10.0.



Model X 16" x 18"
£6.17.6.

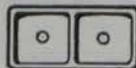

Model XX 18" x 31"
£14.15.0.

Model ZZ 16½" x 35½"
£17.10.0.

VITREOUS ENAMEL SINKS



Model VA
18½" x 36" £5.10.9.

Model VN
18" x 42" £5.16.0.



Model VB
18½" x 36" £5.19.0.

Model VW
21" x 42" £6.17.6.



Model V2
21" x 63" £9.15.0.

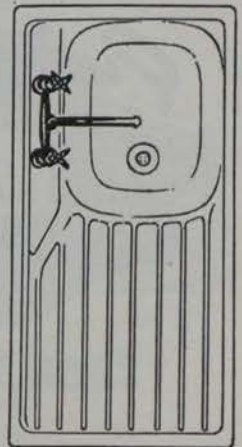

VANITORY BASINS



Standard 15½" x 24½" £5.15.0.
Ultra 17½" x 24½" £7.18.0.

Taps and waste fittings extra

FISHER & LUDLOW LTD (DEPARTMENT) BIRMINGHAM 24



For Life

INTERNATIONAL **Capital** PRESSED STEEL RADIATORS

In Single and Double Panels

- ★ Manufactured in accordance with British Standard BS 3528 and tested to 100 lbs. per square inch (7 Kg/cm²).
- ★ Suitable for use on closed circuit heating installations only, and should not be used on direct domestic hot water circuits or on steam.
- ★ Made from 18 swg (1.219 mm) steel specially supplied for the purpose.

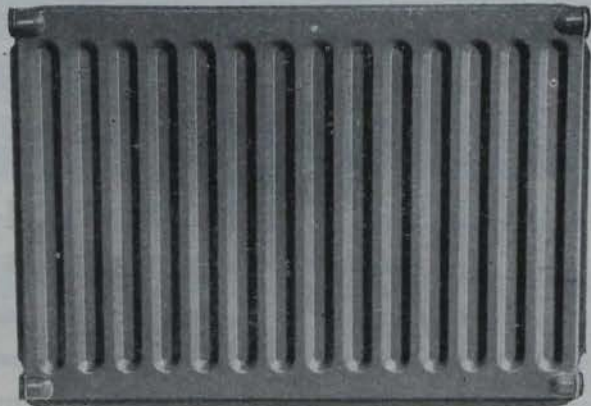

EX STOCK DUBLIN

- ★ Also — THERMOPAK, SILENTFLO, MULTIFLO and THERMOFLO Accelerator Pumps from stock.
- ★ We also carry large stocks of Radiator Valves by all leading makers.

Price list and illustrated leaflets on request

Sole Agents for Republic of Ireland:

MONSELL MITCHELL & CO., LTD.

67-73 TOWNSEND STREET, DUBLIN, 2. 'Phone 76282.

Quick automatic change

FROM HALF-CUT TO FULL-CUT



"48" PATTERN PATENT ADJUSTABLE RATCHET TYPE CHASER DIE STOCK

"48" Pattern Chaser Die Stock 1½", 2" and 4" B.S.P. Quick automatic change from half-cut to full-cut enables threads to be formed, when required, in two operations on 2" and 4" sizes (Patented).

THOMAS CHATWIN & CO.

Victoria Works, Great Tindal Street, Birmingham, 16.

Telephone: Edgbaston 3521-3.

CHATWIN also manufacture

Stocks and Dies (Angular and Square Pattern) Pipe Cutters Stillson Pattern Pipe Wrenches Screwing Machines up to 2" (Pipe and Bolt) Stocks, Taps, Dies, Tap Wrenches in polished wooden cases

ONE OF THE **BROCKHOUSE** COMPANIES

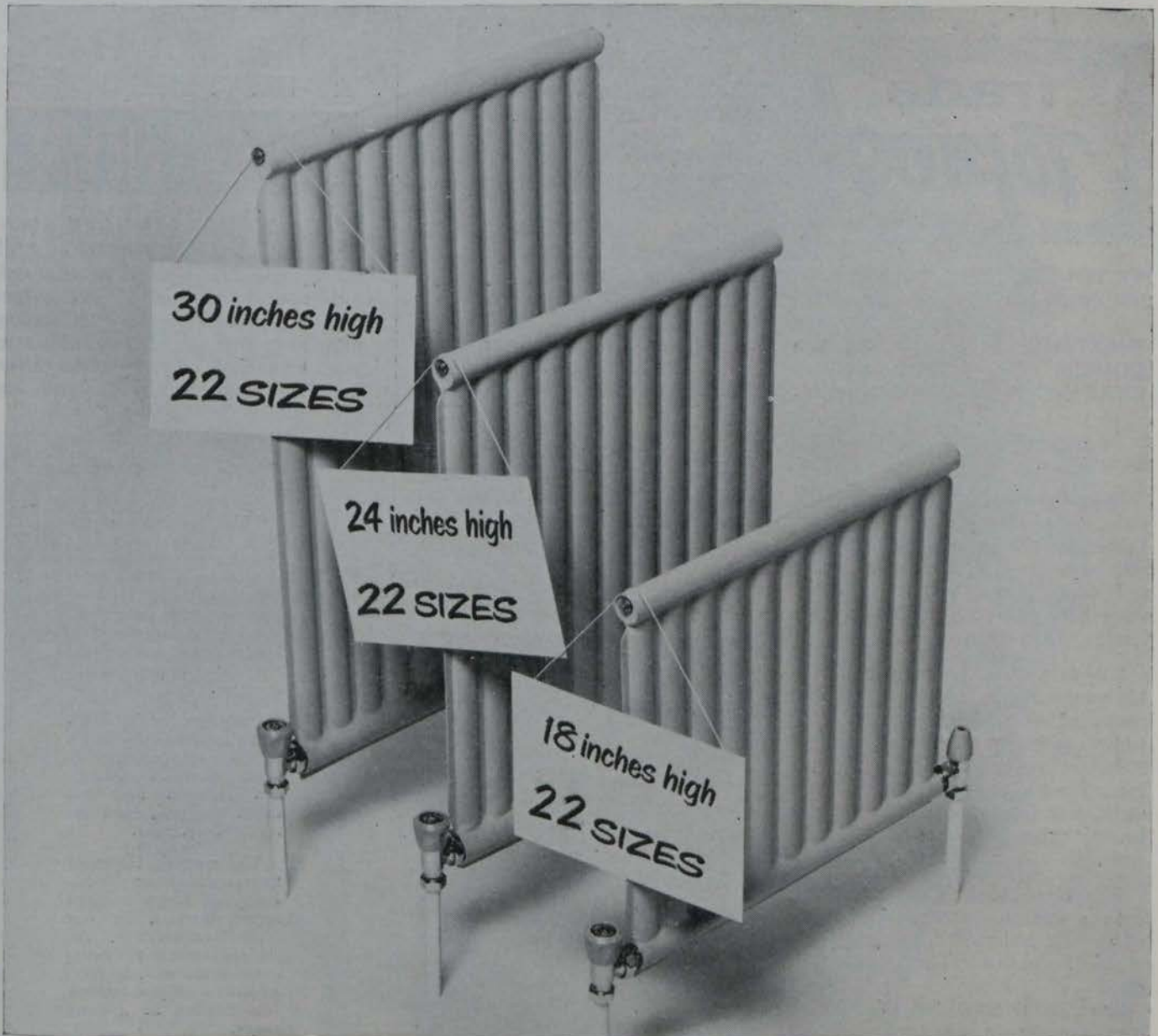

There isn't a room you can't accurately heat from the 66 Potterton radiators

Potterton radiators' range of sizes has been carefully scaled to give really fast production.

The result is 66 sizes—from which you can more accurately meet customers' heating requirements.

Fast production helps to keep a good stockpile. So you've no worries about delivery.

Potterton radiators' heat emission is guaranteed correct. This saves your time.

You don't have to specify more, or bigger radiators than are needed.

Your customers get all the warmth they want. Which makes more satisfied customers for you.

Installers know where they are with Potterton radiators. They cut out guesstimating. They're dead accurate.

Order the new Potterton radiators now. You can get them immediately—in all 66 sizes.

Pick your Potterton radiators at:

John R. Taylor Limited, 379 South Circular Road, Rialto, Dublin 8

The Irish Plumbing and Heating Engineer.

trade Topics

POLYGLAZE LTD., who pioneered their double glazing system four years ago, have now brought out two new systems, both of which permit the double glazing to be removed temporarily or during the summer.

The new systems, known as Polyglaze Two Framing and Polyglaze Three Glass Framing, will be available soon from all hardware dealers and do-it-yourself suppliers. Polyglaze have also improved their original System One.

Polyglaze Two Framing comes in kits containing 16 ft. of three different pieces of white PVC extruded strip which can be cut to make a frame for Polyglaze styrene acrylonitrile sheeting. The sheeting is purchased separately, and is available in convenient lengths either 21 inches or 42 inches wide.

Polyglaze Three Glass Framing is even simpler to install. It consists of flexible white PVC extruded strip which can be cut to form a frame for glass.

Sole distributors of Polyglaze double glazing materials in Ireland are Brook Thomas & Co. Ltd., 4 Sackville Place, Dublin 1.

* * *

GROSS revenue from Limerick Gas Works for the half-year ended September 30 was £104,959, with a net profit for the half year of £1,351, says a report from Limerick Gas Department.

Sales netted £78,000, an increase of almost £8,000 over the corresponding six months of the previous year, despite a reduction of 8 per cent. in the quantity of gas produced.

Explaining the fall in production, the City Manager, Mr. T. F. Mc-

two increases in price over twelve months.

* * *

MEL Engineering Company (Dean Road, Handforth, Cheshire) has introduced two variable head accelerators, the Avon and the Bollin.

With the pumps the required duty can be selected in seconds prior to or after installation.

The pumps are suited to all domestic installations. The Avon is designed for medium type installations and the Bollin for the smaller back boiler type installation.

The silent running pumps—they carry a two-year guarantee—incorporate the Mel automatic self cleaning and de-airing device. This ensures a “dirt free” pump at all times and enables the pump to be installed in any position.



New control

THE Venotrol, a new design of Venner control unit for the economic use of domestic (or business) gas or oil-fired boilers, provides six combinations of time switch and thermostatic control to meet seasonal demands and family needs.

The Venotrol is available for surface or flush panel mounting with provision for conduit entry and normal terminal block connections and the time switch is arranged to operate on and off either once or twice at adjustable times in 24 hours. Two warning lights, indicating “boiler out” and “mains on,” are mounted in the centre of the panel.

IRISH PLUMBING & HEATING

ENGINEER

Vol. 4. No. 10. JANUARY, 1965
THE IRISH PLUMBING AND HEATING ENGINEER is the only publication produced in Ireland catering exclusively for the heating, plumbing and ventilation industries with a guaranteed circulation covering the Republic of Ireland and Northern Ireland every month.

This first issue of the New Year brings with it another stage in the development of the Irish Plumbing and Heating Engineer, the only publication produced in Ireland to cater exclusively for these important industries.

In future the I.P.H.E. will comprise three main sections—a new monthly centre section for Northern Ireland, and our usual domestic and industrial sections.

The new development means a further broadening of scope without any reduction in our established services. All the old features are being maintained and, in fact, additions are planned for introduction at a later stage.

Also new with this issue is a reply-paid reader enquiry form. It is designed to aid readers in getting speedy replies to problems and queries. So, please use it!

Editorial and advertising offices:
 Callaghan Chambers, 13/15
 Dame Street, Dublin 2.
 Tel. 56465-6.

London: J. T. Robson & Son Ltd., 30 Fleet Street, London, E.C.4. Tel.: Fleet Street 4438.

Belfast: 26 Carnamena Ave., Belfast 6.
 Phone: 643095.



WHY THE OPIOMATIC JUNIOR IS THE PUMP FOR ALL BUT THE VERY BIGGEST DOMESTIC INSTALLATIONS

Some people call a giant 'Tiny'. It appeals to the English sense of humour.

We called the Opiomatic Junior 'Junior' for much the same reason.

The Opiomatic Junior weighs 6 lbs. less than the Opiomatic. It's smaller, neater, and cheaper than the Opiomatic. Everything else about the Opiomatic Junior is full size.

Consider the facts. The Opiomatic Junior adjusts at the turn of a handy knob to any

selected duty up to 5.5 ft. head at zero flow and 2.5 ft. head at 18 GPM. With maximum water temperature of 200°F, and maximum static pressure of 50 lbs. p.s.i., the Opiomatic Junior is the pump for all but the very biggest domestic installations.

There can't be many installations in your town that are too big for the Opiomatic Junior. In fact, you could probably count them on the fingers of one hand.



NOW READ ON →

NORTHSIDE HOUSE,
MOUNT PLEASANT,
COCKFOSTERS, HERTS.

Reporting

A DOMESTIC FUEL COSTS CHART WAS RECENTLY COMPILED BY THE DUBLIN FIRM OF BUILDING AND CIVIL ENGINEERING CONTRACTORS, G. & T. CRAMPTON, LTD. BEFORE PUBLISHING THE CHART WE ASKED THE VARIOUS FUEL INTERESTS CONCERNED FOR THEIR COMMENTS.

THE CHART

Type of Fuel	Type of System	Approx. Maximum System Efficiency	(Total Heat Input to System) in Therms	Current Cost per Useful Therm	Approximate Annual Cost
TURF	In open fires of 24 hr. type	40%	1588	1/5d.	£112 9 0d.
ANTHRACITE	In patent boiler	70%	907	1/0d.	£45 7 10d.
OIL	Circulated Hot Air	70%	907	1/4d.	£60 9 0d.
GAS	Circulated Hot Air	70%	907	In any 3 months, 3/- for 1st 50 therms; 1/6d. thereafter.	£75 10 0d.
ELECTRICITY	Ground floor warming plus plug in convectors.	100%	635	In any 2 months, 3/9d. for 1st 360 therms; 2/11d. thereafter.	£119 5 0d.

Q is determined from the equation $Q = \frac{H}{n}$ where Q = total input into the system; H = heat output required and "n" is the system efficiency.

The annual fuel costs shown in the Chart have been based on a heating season of thirty-three (33) weeks, and the examples obtaining are those for a conventionally constructed, semi-detached house of 800 square feet floor area. The seasonal heat requirements for a reasonable standard of comfort has been assumed to be 825 therms, with a saving of 165 therms for miscellaneous inputs (body heat, solar heat, cooking and water heating, etc.). It must be borne in mind that system efficiency is not always the same as the house efficiency. Usually a reduction in overall efficiency occurs due to the location and installation of the system. Hence a 60% house efficiency using electricity for ground floor heating. (Compiled by Messrs. G. & T. Crampton Limited, Ballsbridge, Dublin, 4, "with acknowledgments to The Institute for Industrial Research and Standards for their help.")

THE COMMENTS

TURF

COMMENT: Bord na Mona.

IN the text it is stated that the total seasonal heat requirements are 825 therms, but that 165 therms are available from sources other than the heating system. The nett heat input would, therefore, be 660 therms. In the chart, however, it is implied that the nett heat input is 635 therms. As the calculations in the chart are based on the latter figure, this is assumed to be the correct one in the brief discussion below.

The figure of 635 therms should be divided by the fractional system efficiency to find the total input of therms required. This calculation has been carried out correctly in the case of electricity with an assumed efficiency of 100% the total therms are naturally equal to the useful therms, and in the case of turf, where the efficiency is assumed to be 40%, the total input is given as 1,588, which is

635 + 0.4. From this point onwards, however, the chart is in very serious error. Instead of multiplying the figure for useful therms (635) by the price per useful therm, the compiler has used the figure for total therms.

In the case of turf the figure was 1,588, which gives, of course, a cost of 2½ times the true amount. The annual cost of heating with turf fuel should, therefore, on the compiler's own assumptions, be £45 and not £112 9s. 0d. A similar injustice—though not so gross—has been done to anthracite, oil and gas, where the true costs should be 70% of those given on the chart.

In the text there is a reference to "house efficiency" which we find difficult to understand, and a figure of 60% quoted for the house efficiency using electric floor warming, which does not appear to have been used in the table. The text should, of course, explain the chart to the reader, but we feel that this reference would only tend to confuse the issue.

Even if the calculations were correct, we could not accept the basis on which the assumptions were prepared. No doubt the compiler felt that in order to put all the fuels on the same basis, he had to assume that the house warmed by turf was equipped with an open fireplace in every room (and perhaps in the hall) and that a fire was kept burning continuously in each fireplace throughout the heating season. We do not feel that any reasonable person would, in fact, adopt such a scheme and we certainly would not wish it to be taken that a system of this type would be recommended by us. We do know of many people who warm their homes satisfactorily with turf fuel for far less than the figure of £45 which should have appeared in this chart.

The chart confines itself to fuel costs only, and makes no reference to capital or other charges, and we feel that if due account were taken of these, an entirely different picture would be presented.

Continued overleaf

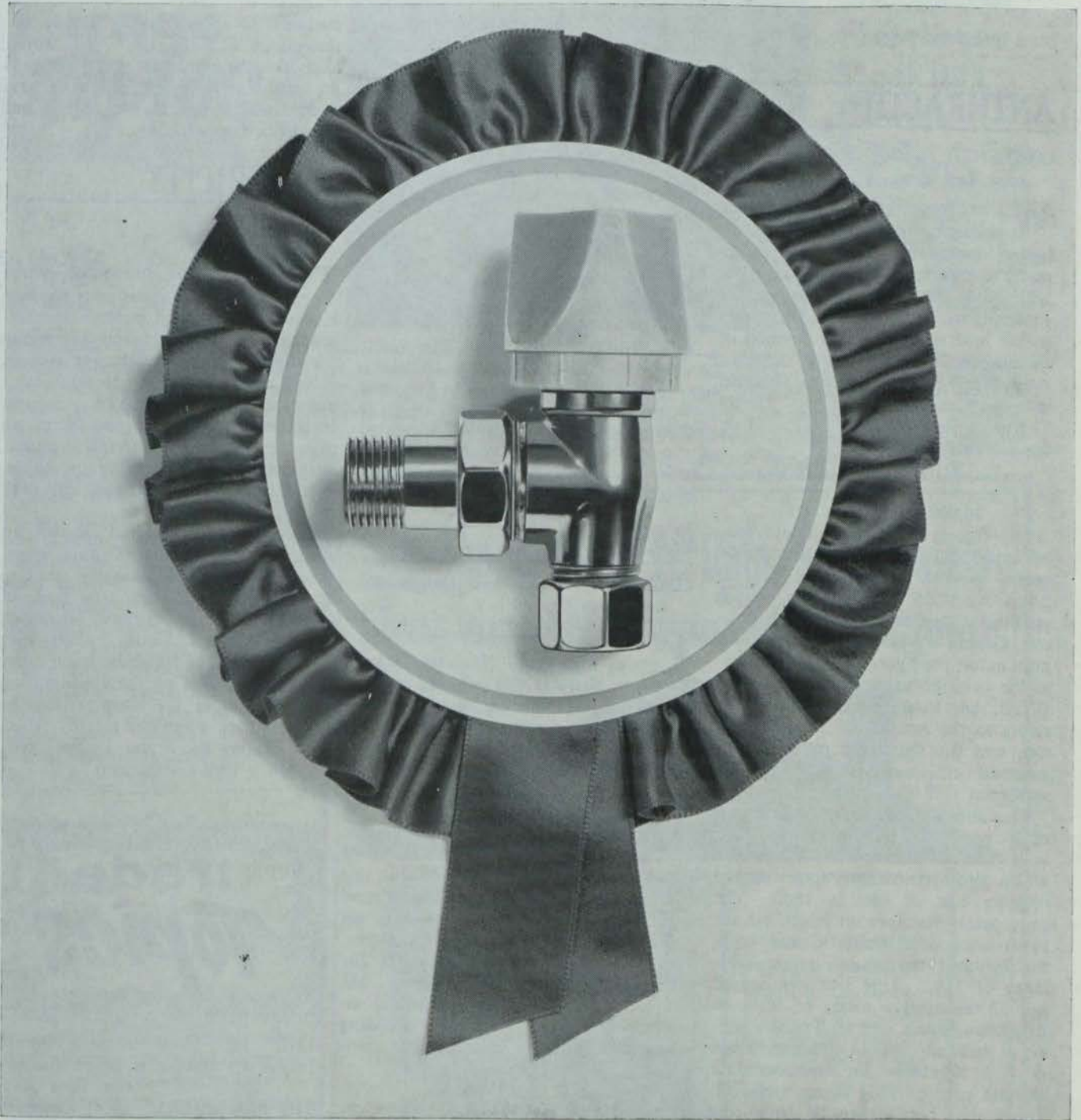

WHY THE BSA HARFORD TWIN ACTION VALVE IS THE BEST IN THE BUSINESS

Here are the facts about the modified BSA Harford Twin Action valve. You'll want to know them—because the Twin Action valve has been improved to give you the higher efficiency and greater ease of installation you asked for.

New stamping and machining methods make the Twin Action valve much more accurate and precise in tolerances—much smarter too! The valve is now stamped and has been modified to a 1/2 inch B.S.P.A. male thread pattern. Heat

output is regulated according to the position of the handwheel. The ingenious design of the handwheel allows accurate, simple control of water flow at a turn—intermediate positions are marked on the side. The valve can also be preset to limit flow through radiator. No sticking. No dripping.

All Twin Action valves are supplied complete with compression nut and olive. Available in brass or polished chrome. For use with copper pipes only.

BSA
HARFORD
Northside House,
Mount Pleasant,
Cockfosters,
Herts.



The Irish Plumbing and Heating Engineer.

from previous page

ANTHRACITE

COMMENT: Heating division leading solid fuel firm.

WE are most grateful for the opportunity to comment on the figures quoted in the chart for automatic anthracite boilers and we here-with have pleasure in giving you the exact figure as it obtains to day together with details of our method of calculation. This, naturally, is in accordance with the accepted manner of establishing the cost per Useful Therm of any fuel. This is based on the following equation:

$$\frac{100,000 \times 12.55}{14,000 \times 2240 \times 0.8}$$

The figures contained therein may be explained as follows: the 100,000 refers to the therm in B.T.U. per hour; the 12.55 is the cost in pounds sterling of one ton of Welsh Anthracite Grains. With regard to the denominator, the figure of 14,000 refers to the calorific value of Anthracite in B.T.U. per hour, the figure of 2240 refers to the number of pounds in a ton, and the figure 0.8 refers to the assumed efficiency of 80% for the appliance.

The above quotation gives a figure of 1/- per Useful Therm, which agrees with Messrs. Crompton's figure and which also approximates to the annual running cost of £45 7s. 10d. The only point, therefore, at which we are at variance with Messrs. Crompton is the assumed maximum system efficiency of 70%. This firm has carried out an exhaustive series of tests on magazine boilers, and on Trianco boilers in particular and an efficiency figure of 80% would be far more accurate in this case. This figure, you will notice, has been taken by us in the foregoing equation.

OIL

COMMENT: Head of leading oil company's domestic heating division.

MY feelings concerning fuel costs are that as long as the exact details as to how these costs are arrived at are given and the source of these details is checked before they are compiled, then there is generally no objection. I understand from you that these costs refer to a three bedroomed semi-detached house and judging from the input of 907 therms this would appear to be a very small heat

load indeed. Whilst the comparisons between the various fuels may be accurate this could lead a number of people to believe that the running cost per annum of any system is far smaller than it might be.

Our calculations are based on full central heating for a four-bedroomed house and we base these on a heating requirement of 36 therms per week for 30 weeks, which gives a higher figure than coupled with the domestic hot water requirement of 4.5 therms per week for the remaining 20 weeks. The total annual heat requirement with central heating and hot water combined during the winter and domestic hot water during the summer would be more in the region of 1,170 therms per year than the 907 suggested above. We stress that this gives a more realistic running cost where full central heating is envisaged.

GAS

COMMENT: Alliance and Dublin Gas Consumers Co.

THE chart, as we have seen it, contains several inconsistencies. However, there is one mistake in the section dealing with gas: the list price of gas is 2/5 per therm for the first 50 therms per quarter, not 3/-. This has the effect of reducing the annual

fuel cost to approximately £73 4s. 0d. instead of £75 10s. 0d. We would also like to point out that there is no annual service charge for a gas-fired heating system; we carry out this work free of charge.

ELECTRICITY

COMMENT: E.S.B.

TO minimise the headaches which this table may cause your readers, I would ask you to publish the following correction of fact: Electricity for floor warming by storage is sold at 0.8 per unit (falling to 0.6d. with high consumption). 0.8d. per unit corresponds to 2s. 0d. per therm, so that the cost of 635 therms, the total heat input assumed in your table, would be £63 10s. 0d. and not £119 5s. 0d., as stated.

Even if the table had shown an accurate comparison of fuel costs, your readers would scarcely need to be reminded that the true cost of domestic heating depends on more than fuel costs alone. Only with proper allowance for capital and other charges attendant on the consumption of fuels can a full comparison be made of their economic merits. Electrical heating can stand up very well to such a true comparison.

THE big 3,000 dwelling development planned for Ballymun, Dublin, is to include centrally heated high and low rise flats on the Balency system. The Minister for Local Government, Mr. Blaney, has had the Government's approval to nominate the National Building Agency Limited to enter into and manage the contract.

* * *

WHESSOE Limited have disclosed that their recently acquired subsidiary, Universal Fabricators (Dublin) Limited intends to change its name to Whessoe (Ireland) Limited.

Whessoe have made the following nominations to the Board of the Irish Company: John H. Lord, Chairman; M. J. Noone, Deputy Chairman and Managing Director; A. W. Wagstaff, R. Slater, and W. C. Holliday.

Following the acquisition, Mr. H. L. Reynolds has resigned from the Board of the Irish Company.



THE 1st International Plumbing Trades Exhibition is to be staged at the Free Trade Hall, Manchester, from May 25 to May 28 next year. "Investigation amongst the plumbing trade has shown that there is a definite need for an exhibition which specialises in featuring all the products used or fitted by the plumber. They do want to see, all under one roof, a complete range of plumbing components," said a spokesman for the organisers.

The exhibition will be confined to the trade only, and invitations to attend will be distributed to plumbers, builders and plumbers' merchants, heating engineers, architects, building contractors, municipal authorities, and national undertakings and the like.

Following the acquisition, Mr. H. L. Reynolds has resigned from the Board of the Irish Company.

trade Topics

THE International Heatmiser saves fuel in the way it helps to control automatic boilers which supply domestic hot water and small bore central heating.

HEATMISER CUTS THE FUEL BILL

The Heatmiser is a device which is used with a room thermostat and a cylinder thermostat to ensure that both the boiler and pump come on when central heating is required, and that the boiler only comes on when only hot water is required, and that the boiler is off when neither is required.

The unit comes into its own when no central heating is required—because it is warm day or because the house is warm enough. Because the boiler then responds only to the thermostat fitted in the hot water cylinder, no fuel is wasted in keeping up continuously the temperature of the water in the boiler and in the pipes leading to the hot water cylinder. The Heatmiser is incorporated as a standard in all International Capital boilers.

* * *

THE Airlpel-Vandi humidifier—it is available from Monsell, Mitchell & Co. Ltd.—corrects

INEXPENSIVE HUMIDIFIER FROM M.M.

dry heat and alleviates such problems as damage to woodwork

and furniture.

This low-priced unit with its special filter wick provides an inexpensive answer to the dry heat problem often posed with central heating. Hanging on a hot panel or column radiator, it evaporates nearly two pints of water into a room every twenty-four hours.

* * *

LATEST product from Charles Portway & Son Limited (Halstead, Essex)

NEW HOME HEATER BY PORTWAY

is the Trio Home-heater, an oil fired radiant convector heater with hot water supply integral.

The Trio has a gross output of 30,000 B.t.u./hr.; domestic hot water up to 8,500 B.t.u./hr. radiation up to 9,000 B.t.u./hr. and convection up to 12-13,000 B.t.u./hr.

The Trio fits any 14, 16 or 18 inch standard fireplace. Its heater body



Successful Flemings Stockists Dinner

● At the recent Flemings Fireclays Ltd. wholesale stockists' dinner, held in Jury's Hotel, Dublin, were (from left): Mr. J. M. McNaughton, vice-chairman, Fireclays Association, and Mr. G. P. Fennell, Sales Manager, Flemings' Fireclays Ltd.

is in heavy duty cast iron, its casing is in heavy gauge corrosion treated sheet steel, and the domestic boiler is 1/4-inch mild steel plate pressure tested to 20 p.s.i.

EXPORT orders to the value of at least £275,000 were obtained by The Valor Company's Managing Director, Michael J. Montague, during his recent ten day visit to Japan.



the Terrain PVC Rainwater System

gives you this unique leak-proof joint





* Rust-proof * No painting needed * Light * Choice of colours * Long-lasting * Easy to erect * Fully approved * Terrain PVC soil and waste systems also available in matching colours.

* Plain-ended gutters and fittings simply push into joint brackets



UNIDARE LIMITED, FINGLAS, DUBLIN 11.

The Irish Plumbing and Heating Engineer.

FLUED CONVECTOR CEVE 2150

COMBUSTION AIR REGULATOR
KEEPS BURNER AT
MAXIMUM EFFICIENCY

With running costs which can be as low as 19 hours on one gallon of oil, this new oil fired convector heater from CEVE Ltd. has been specially designed to provide full convection. It is a slim-line model in which burning is regulated by one simple fuel control which prevents waste fuel consumption. It can also be regulated by room thermostat.

A special draught regulator keeps the burner in its maximum efficiency condition and avoids all warmth losses through the chimney. Heat output ranges from 8,000 Btu/h to 28,000 Btu/h according to the setting and allowing this to use only the necessary amount of fuel according to the temperature requirements.

The CEVE 2150 has an overall height of 28 in., a depth of 12 in. and an overall width of 21 in. and will thus fit practically every standard fireplace without removing the surround.

The unit is fitted with a large size heat resisting glass fire panel which creates a cosy, cheerful atmosphere in the house but also gives the effect of a comfortable open fire—behind glass.



- ★ The heater is rigidly constructed in sheet steel with wipe-clean vitreous enamel finish. Stainless steel burner guaranteed for 10 years.
- ★ Dimensioned to fit every standard fireplace.
- ★ Technical documentation and test results will be forwarded on request.

Enquiries to Irish Agents:

ORBIT SALES LTD.

47 Sth. William Street, Dublin. Telephone: 71655.

EASY COMPACT INSTALLATION FOR WATER SUPPLY



Self-priming with a suction lift of 25 feet, the electric driven M range of Mono Pumps are compactly constructed, flange mounted to a motor of very low power consumption. Its silent operation permits installation in any convenient position and the non-pulsating, steady flow will not transmit noise through the pipeline. No oiling or greasing of the pumping element is required and no foot valve necessary.



The MONO pump

Attractive terms to Dealers

MONO PUMPS LIMITED, 34
<https://arrow.tudublin.ie/bsn/vol4/iss10/p1>
DOI: 10.21427/D72D9C

CENTRAL HOTEL CHAMBERS, 7/9 DAME COURT, DUBLIN.
Telephone Number: Dublin 70843.

MP251

THE Vokes Group (Irish agents, Leinster Engineering Co. Ltd.) has published a catalogue giving details of films available from its 8 mm. and 16 mm. film library.

* * *

AT A Board meeting of Walker Crossweller & Co. Ltd., held last month, an interim dividend of 5 per cent. less tax was declared. For the half year to September 30 the group nett profit is £81,289 before tax deduction.

* * *

APPLIANCE Components Limited (Martin Road, Cordwallis Industrial Estate, Maidenhead, Berks) have just launched a new version of their Motortrol motorised valves. This latest idea consists of the incorporation into the body of the motorised valve of an externally adjustable butterfly which acts as a balancing cock and thus enables the circuit to be controlled and balanced from the same unit.

* * *

AFTER three years of operation and continuing expansion, Powell Duffryn Heating Limited have decided that it is in the general interest to standardise upon the single brand name Powell Duffryn for all their products. This change means that the names Janitor, Gulf, Hurseal and Tayco will no longer be used officially, and all printed matter will be brought into line at the earliest opportunity.

NEW FLUSH TROUGH SYSTEM

A NEW continuous flush trough system, in glass fibre, suitable for use in all kinds of public buildings, factories, offices, hospitals and schools, is announced by Shires. Known as the Polyflush, it is designed to give maximum efficiency and reliability with low installation costs and minimum maintenance.

Finished in an attractive shade of light grey that goes right through the material, it will match any colour scheme and never needs painting. Easy to clean and completely unaffected by hard or soft water, the non-corroding glass fibre material combines great strength with low weight and a pleasing appearance.

The Polyflush has a simple volume control to flush 2, 2½ or 3 gallons, which eliminates troubles such as



THE FOUNDER members of the new Plastic Bath Development Association have been listed as: Bathtubs Ltd.; P. & S. Plastics Ltd.; Robin Plastics Ltd.; Henry Robinson (Fibres) Ltd.; Shires & Co. (London) Ltd.; Thermo Plastics Ltd.; and Troman Brothers Ltd.

* * *

E. N. BRAY Limited have established here a subsidiary company for the manufacture and assembly of starters and control panels. The Company will be Enbray (Ireland) Limited with premises at 8, North Frederick Street, Dublin. The selling agents here are Handcock & Company, 36 Dublin Road, Sutton, Dublin.

* * *

MR. J. M. FRASER (31) has been appointed United Kingdom Marketing Manager of Thomas Potterton Limited. Mr. Fraser joins the company from Shell-Mex and B.P. Limited, where, as Assistant Manager, Domestic Fuels, he played an important role in the Mrs. 1970 heating campaign.

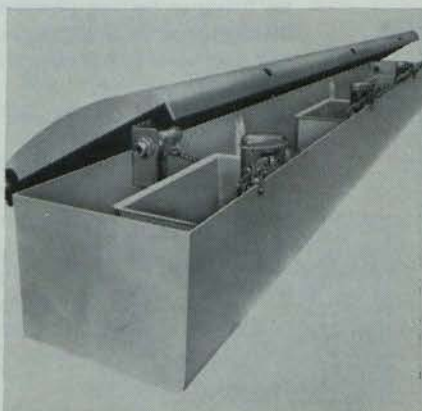

blocked air tubes. It can be supplied to serve any number of units each of which is operated by the Kingfisher siphon—a mechanism that gives a full, powerful flush first time, every time.

Overall dimensions of the Polyflush are 12 in. wide by 9 in. high. A glass fibre cover is available as an optional extra.



New unit

IN the oil fired flued convector 2150 by Ceve Ltd., the conventional draught regulator is replaced by a combustion air regulator, situated at the air intake and supplying to the burner a constant quantity of air regardless of draught conditions. This method avoids waste of ambient warm air up the chimney, and the temperature of the flue gases at low fire—275°F—is claimed to eliminate practically all condensation. The convector is said to have an overall efficiency in excess of 75%, and is suitable for smokeless zones. It can be supplied for connection to a main supply or with built-in tank. It can also be provided with a fan unit.

Designed to fit practically every standard fireplace, the convector has a nominal heating capacity of 28,000 B.t.u./hr. Burning at low fire—8,000 B.t.u./hr.—it consumes only 1 gal. in 19 hours. Recommended fuel is 28 sec. Redwood No. 1 at 100°F.

The appliance incorporates a stainless steel vaporising burner and has a large window of high diffracting fire-resistant glass. It has B.M. or A.P. constant level control and can be supplied with thermostatic control.

Its price is £40 12s. 3d. (plus turnover tax). Other Ceve units are recommended for churches, institutions, garages, etc. All Ceve burners are guaranteed for ten years. The Irish agents are Orbit Sales, Ltd., 47, South William Street, Dublin.

trade Topics

MINIVAL IS NEW SATCHWELL CONTROL VALVE

"ZONE Control for under £10"—
this is the consumer slogan for the new Satchwell Minival motorised valve which, when used with a Satchwell TL room thermostat, provides full zone control.

The inexpensive and reliable new Minival models ($\frac{1}{2}$, $\frac{3}{4}$, and 1 inch) are on-off motorised butterfly valves designed to control the flow of low pressure hot and cold water.

The new valve is particularly suitable for central heating and can be used to control heating zones where on-off control by thermostats or other controllers is required. The valve can be controlled, for example, by a TL room thermostat (list TL 213.01) and a time switch or by any device having a single-pole changeover switch.

The body is high quality brass. All sizes have ends screwed BSP parallel thread and compression fitting adaptors for use with copper pipe are supplied for the $\frac{1}{2}$ " and $\frac{3}{4}$ " sizes. The gland has been carefully designed, using the most up to date materials

in brief...

MR. E. O. KOLADE, Charge D'Affairs at the Nigerian Embassy, visited Wavin Pipes Limited, Balbriggan, last month. On arrival Mr. Kolade was received by Mr. T. F. McMahon, B.E., Chairman and Managing Director, and senior executives. Later he was conducted on a tour of the factory and laboratory.

* * *

IN ORDER to streamline service and delivery arrangements, B.S.A. Harford have decided to increase their range of radiators available from stock, from 54 to 82 sizes. This Alteration to trade facilities became effective as from last month, at a new Dublin office. The new range includes tailor-made, curved and angled radiators.

to give trouble free service and no adjustments or lubrication are required. The driving motor is contained in an attractively styled die-cast housing which is secured to the valve body by two captive nuts. A window in the top of the housing indicates the valve position by showing silver when the valve is closed, changing to red when it is open.

In common with all butterfly valves, the Minival cannot give completely tight shut-off in the closed position. However, it has been designed so that the amount of water that can pass the closed butterfly is a minimum.

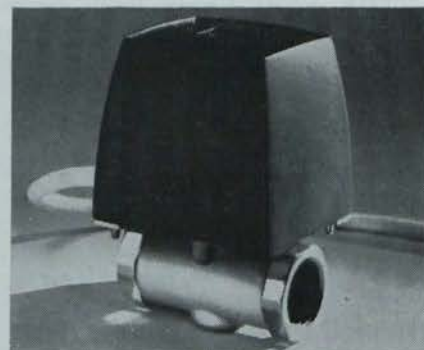

● This is the new Minival from Satchwell which can be so usefully used with the TL room thermostat.

PORTABLE TUBE BENDERS

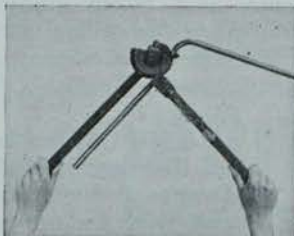

LIGHTWEIGHT BENDING TOOLS

Types GL.O and GL. Minor

Compact machines to produce good quality sets, compound bends, etc., in non-ferrous tube. Robustly built, they can be carried in tool bag and are particularly suitable for small bore heating and similar types of installation.

CAPACITY: GL. O— $\frac{1}{2}$ ", $\frac{3}{8}$ " and $\frac{1}{4}$ " dia. copper tube.
GL. Minor— $\frac{1}{2}$ " and $\frac{3}{4}$ " dia. copper tube.

FOLDING STAND MODELS

Types GL. 2B and GL. 3B

The original and most efficient portable benders made for bending light gauge copper tube. Require no fixing or bolting down and produce good quality bends, cold and unfilled, to exact measurement on standard radii.

CAPACITY: GL. 2B— $\frac{1}{2}$ ", $\frac{3}{4}$ " and 1" dia. copper tube.
GL. 3B— $\frac{1}{2}$ ", $\frac{3}{4}$ ", 1", 1 $\frac{1}{4}$ " and 1 $\frac{1}{2}$ " dia. copper tube.

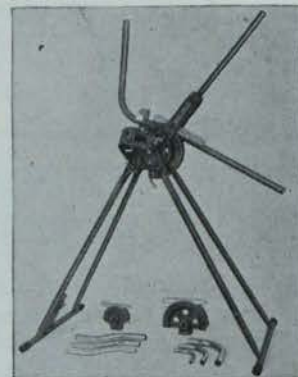

EASY-WORK RATCHET BENDER

Type RP. 5B

A machine of new design with a rotary bending action through a powerful ratchet operated screw. Completely portable, produces good quality bends speedily, accurately and with minimum of manual effort.

CAPACITY: $\frac{1}{2}$ " to 2" dia. copper tube.
 $\frac{1}{2}$ " to 1 $\frac{1}{2}$ " o.d. conduit.
 $\frac{1}{2}$ " to 1" nom. bore gas and steam.

SEE OUR PERMANENT EXHIBITION AT THE
BUILDING CENTRE OF IRELAND, DUBLIN.

FIRST
MADE

HILMOR
TUBE BENDING MACHINERY

FINEST
MADE

For details of range of hand-operated, hydraulic and motorised machines handling up to 8" dia. tube, apply to local stockist or write to:—
Dept. F, HILMOR LTD. (Sales and Service), CAXTON WAY, STEVENAGE, HERTS.

the 7 deadly sins of domestic installation

PART EIGHT



A heating system is a complete assembly of wiring and ironmongery, which is intended to provide a private climate, to suit the customer's taste, at times when the outside world is uncomfortably cold. To suit the customer's taste, this is essential; and one could add that the customer's pocket must be suited as well. This is where the control system comes in; a good control system can ensure that the house is as warm as it needs to be, suiting the customer's taste—and no warmer, suiting the customer's pocket. A good thermostat can sense, and act on, temperature changes long before any human being could feel a change and get up and twiddle the necessary valves. Therefore it is quite reasonable to expect a control system to "think" for itself. The "thinking" should, of course, go beyond the mere control of temperature. If we extend the definition of "control" to cover such devices as safety valves and frost thermostats it becomes possible to classify controls according to their different functions. These functions may be listed as follows:—

- A. The control of temperatures.
- B. Fuel Economy.
- C. Time control.
- D. Safety.
- E. The protection of equipment.

There is bound to be some overlap, for example A and B, or B and C are bound to coincide, but the prin-

cipal controls may be listed, taking the main function first in each case.

This little table may seem to state the obvious but it is a short way of saying what each control is for and this seems worthwhile.



To discuss these different units in order: in all but the most elementary, solid fuel systems, an appliance operating thermostats is standard. The high limit thermostat is not so commonly used for small systems; as the name implies this is a safety thermostat, which is set five degrees F., or more above the operating thermostat and which can only operate if the first thermostat fails. If the effect of overheating will be merely the rather noisy boiling of the system, under circumstances that will cause no danger or alarm and with only a slight wastage of fuel, then the high limit thermostat may be omitted, although ideally it should always be present.

The cylinder relay is a relatively new piece of equipment; briefly it transfers control of the boiler, in a domestic hot water system, from the boiler thermostat to a thermostat reading direct from the cylinder temperature. This is set a few degrees below the boiler thermostat, which becomes, in effect, a high limit thermostat. If the cylinder relay is used, as it generally is, on a system which also

incorporates central heating, then control automatically alternates, according to demand, between the cylinder thermostat and a master room thermostat. Such a system can, of course, only be applied to an automatically controlled boiler; and it ensures long operating cycles, since the control medium cannot rapidly fluctuate in temperature. With one type of system it is possible, and indeed desirable, to make little or no allowance in sizing the boiler, for hot water recovery. The life of the burner is prolonged since the ignition system is subjected to much less strain. The cylinder relay system was also discussed in section seven, so I will say no more on this.



Next, firevalves, an abrupt transition, but I didn't invent the alphabet—I just abuse it! Briefly a fire valve is a device which detects excess heat, i.e., a fire, and cuts off the supply of inflammable fuel to the protected zone. Some firevalves are one-piece, in other words the detecting and the closing function are combined in one body. The disadvantage here is that the fuel pipe, on which the valve is fitted, is normally at low level. A fire detecting device should be well above the floor; any fireman will tell you that the floor level is normally the least heated part of a burning room, therefore the best fire valve is in two parts, with the temperature detecting device fitted three feet or so above the floor. Operation may be electrical, by a wire, fusible link, and deadweight or spring closure valve, or by a valve operated by a sensing phial and capillary tube. Fitting the right type of fire valve is not usually mandatory, but in this writer's humble opinion, it ought to be. Modern appliances are safe enough but fires can arise from

1. Boiler or furnace operating thermostats ..	A.B.
2. Boiler or furnace high limit thermostats ..	D.E.
3. Cylinder relays (as discussed in Part 7) ..	B.A.E.
4. Fire valves	D.E.
5. Frost thermostats	E.D.
6. Gas governors	D.E. indirectly A.
7. Mixing valves, manual and motorised	A.B. sometimes E.
8. Non-return valves	B. (usually).
9. Room thermostats	A.B.
10. Room thermostats with automatic setback ..	A.C.B.
11. Safety valves	D.E.
12. Thermostatically controlled valves and dampers ..	A.B.
	C.B. sometimes A.

Continued overleaf

NO WAITING WITH WARMEX

ECONOMIC

CENTRAL HEATING

EVEN DURING PEAK PERIODS

With Warmex there's no waiting for off-peak periods. It provides instant heat WHEN AND WHERE YOU WANT IT, evenly controlled by time switches and automatic controls and surpassing the economy of electric storage heaters—without their bulk. The Warmex System can be easily installed at a very moderate cost. Furthermore, Warmex radiators are guaranteed for five years.

- This unique construction is fully patented.
- Easy payment plan. Personal loans available.
- Installation takes only an average of two days without any structural alterations.
- Time clocks set to your own particular requirements.
- Pullin thermostats control your heat.
- Running costs are very economical.

GUARANTEE

The WARMEX system is guaranteed for five years.

Synchronous Time Switches

by

**ENGEL & GIBBS
LTD.**

Timekeeping is controlled by high quality gears made to the best Swiss standard and the time switch is enclosed to prevent interference or damage from dust or dirt.

Sole Concessionaires in the Republic of Ireland, to whom all enquiries should be addressed:

20th CENTURY ELECTRONICS
(Ireland) LTD.

38/39 Grafton Street, Dublin. 'Phone 70939.

domestic installation

from previous page

other causes and it seems only sense to ensure that inflammable fuel is not allowed in to feed such fires.

Frost thermostats are designed to sense and respond to any temperature drop below freezing point outside the house. When such a drop occurs the frost thermostat cuts in the boiler, regardless of the setting of other controls, such as a time controller. These units are well worth while for outside boiler houses, where a circulation could freeze solid overnight, but are not quite so essential when the boiler is fitted within the heated area, perhaps in the kitchen.



Gas governors or regulators, like oil burner control boxes, are fitted as standard in the appropriate appliances. Since, therefore, no question of their selection or usage is likely to arise, there is no need to discuss them further.

Mixing valves, as used in domestic practice, are usually hand controlled, generally with an inbuilt thermostat to hold a selected temperature, or automatically controlled by an outside thermostat with an hydraulically operated device, powered by the pump, to make temperature adjustments. The latter type is, of course, to be preferred. The motorised three-way and four-way valves used in larger systems are really beyond the scope of this series.

A boiler, used for a combined system, has two rather conflicting jobs to do. It has to provide domestic hot water, normally at a constant temperature, and central heating, to meet a constantly varying requirement. The mixing valve enables these two functions to be separated so that the boiler can supply water, from the same source, at different temperatures. Despite this apparent advantage the usage of mixing valves in domestic heating systems is not as great as seemed likely a few years ago.

There are two ways in which non-return valves are commonly used in domestic heating. Some gravity circulation is usually possible in any

from previous page

pumped system; this can be an annoyance to customers since an unwanted circulation can be very wasteful. The remedy is a lightweight valve in the heating flow which opens under the influence of the pump. Such a valve must operate silently and must not impede filling or the venting of air.

The second application is the prevention of reversed circulation on the gravity circulation to the hot water cylinder. This reversal, which occurs with certain types of boiler, only takes place when the pump is running. One way of preventing this is to fit a non-return valve on the hot water return close to the boiler and opening into the boiler. A small branch, usually half inch, is taken from the hot water return, on the upstream side, and into the heating return before it enters the pump. The operation of the pump pulls the valve shut and pulls water down the return from the cylinder, thus assisting circulation. When the pump stops the valve opens and normal gravity circulation takes place. It is necessary to fit a lock-shield valve on the small branch and to adjust this to balance the rest of the system.

Room thermostats are familiar devices; the more sensitive types usually have built in heaters to accelerate the response. Some room thermostats are designed to "set back" a few degrees, either at a pre-set time or in response to a light sensitive cell. The main trouble with room thermostats is that designers tend to use only one to a house, presumably because of cost. It is not always satisfactory to try and control an entire house, or, worse still, a sprawling bungalow, from one point.



Turning now to safety valves; I have strong feeling about these. Some people I once knew were tragically involved in the winter of 1962 when a back boiler, sealed by ice, exploded with dreadful results. Had a safety valve been fitted a life would have been saved and other people present would have been spared serious injury. Need I say more.

Thermostatically controlled valves and dampers are among the heating engineer's most useful tools. Properly used they provide on the spot temperature control and three or four of these, at key points in a small house, cost relatively little and give good results. Their use is increasing. The familiar devices, but they lead on to this

THIS sparkling and well-informed series is by W. J. R. COUCHMAN. Mr. Couchman maintains close contact with the trade throughout Ireland and is ideally informed to compile this series.

month's "deadly sin." Any installer can set a time controller, but can any customer? No matter what the control system may be, the installer's job is not complete until he has painstakingly drilled the customer—who has paid for all this—in the correct use of the system. If this is not done, then the customer is not getting value for money.

ingly drilled the customer—who has paid for all this—in the correct use of the system. If this is not done, then the customer is not getting value for money.

They don't let you D O W N at Wilsons

Every Wilson oil-fired boiler is fired and tested for you before it leaves the works. The outputs are guaranteed, *tested* outputs into water

Every Wilson radiator has a guaranteed emission figure—a figure calculated to B.S. : 3528 : 1962 by the Heating and Ventilating Research Association, Bracknell.

All boilers are very accessible for your checking and cleaning —saves you time on the job. And if there *is* trouble with a Wilson installation, we do want to hear about it. Because it is not our custom to assume that the installer must be at fault.

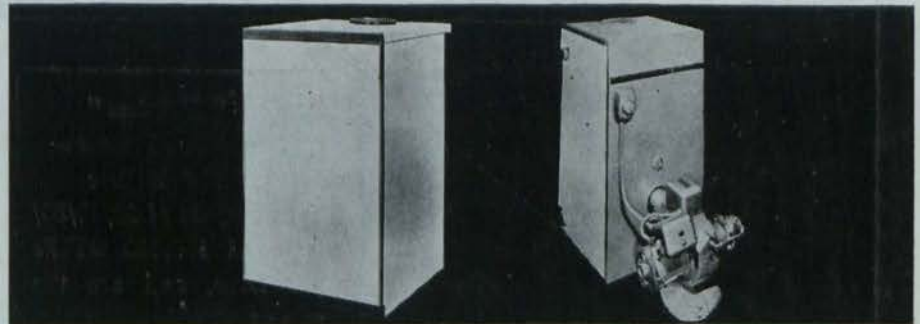

Wilson Wallflame. Five models available with outputs from 45 to 150 thousand B.T.U. Advanced technical design without frills. The biggest selling wallflame boiler in the country.

Wilson Boiler/Burner Units. Pressure-jet fired. Outputs from 70 to 800 thousand B.T.U. Larger models now with Wilson Cosytube baffle for maximum corrosion-free life.



Wilson Radiators. Their extra slim design makes them favourites with housewives. 816 sizes with standard popular range for quick delivery.



Full details from

Henry Wilson & Co. Ltd.

Sales & Service Office, George A. Reid Esq.,

16, Fade Street, Dublin.

Telephone: 76009.



The Irish Plumbing and Heating Engineer.

PERKINS

**1988
BOILER
MODELS
IN
1965**

**PC SERIES—60,000
to 1,000,000
BTU's/hr.**

The construction of all Perkins oil fired boilers is from high quality steel and designed exclusively for oil firing. The design incorporates multi-horizontal water tubes arranged spirally, in order to ensure that no combustion heat passes into the flue without having first come into contact with water-wetted, heat transfer surfaces. The boiler is adequately insulated to reduce heat loss to a minimum.

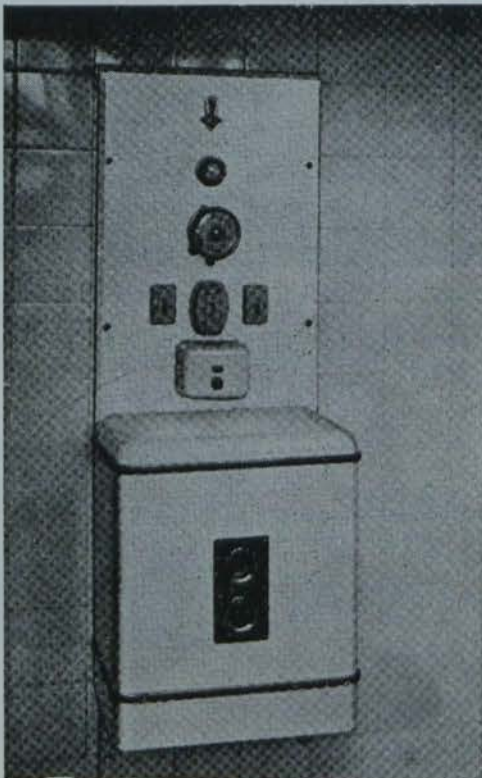

**Perkins "Flue-less"
Wall-mounted Pressure-
Jet "Mini" Boilers**
have outputs of 50/60/80/
100 and 150,000 BTU's
per hour, and are the
most highly efficient,
fully automatic boilers
available at any price.

Sole Concessionaires for
Republic of Ireland:

**OIL FIRED
HOMES
(Ireland) LTD.**
6 HARCOURT ROAD,
DUBLIN.
Telephone 54736.

Standard Domestic Fuel Oil and BP Domesticol are recommended fuels.

trade
Topics



● THE
EXECUTIVE
MK 11A.

Portable unit

A NEW portable air conditioner designed for domestic or office use is now available from Hygro-Robot Ltd. (68 Oxford Street, London, W.1.) Known as the Executive MK IIA, it sells for as little as 18 guineas but will efficiently condition a room as large as 2,000 cu. ft. capacity.

Originally developed from the design of a young Swiss engineer from Aarau, the Executive MK I was a small air conditioner used successfully in heated bedrooms and the like, but it was insufficiently powerful for general use. The new Mk IIA, however, developed in co-operation with the Testing Houses of Electricity Boards, is adequate for most tasks, the patented filtering arrangement providing a very powerful evaporative system in compact form.

The unit works on the evaporative principle, stale dry air drawn in by a fan being washed and forced under pressure against the sides of a zig-zag filter with an effective length of 5ft. 4 ins. The construction of the unit allows the humidified air to pass through three pressurising stages before being released clean, fresh and with the correct moisture content for optimum comfort. Smoke and other impurities are eliminated by the filter, but because the humidified air is not forced through the filter unit, the system is self adjusting and cannot over-humidify.

industrial heating & ventilating

IN IRELAND



ANDREWS-WEATHERFOIL Ltd., of Slough, Bucks., have opened a new branch office for the Republic of Ireland at 6, Westmoreland St., Dublin, where full design facilities are available. The new branch is equipped to deal with contracts for all types of industrial and commercial heating and air conditioning, including the installation of equipment.

The Director of the Irish branch, which opened on the 23rd November last, is Mr. J. G. Barber, A.M.I.H.V.E. Telephone 79607.

* * *

VAN DEN BOSCH LTD. (Europair House, Alexandra Road, Wimbledon, S.W.19, have introduced Bi-flex

NEW AIR DUCTING INTRODUCED Type INC incombustible flexible air ducting

which supercedes Bi-flex Type NF non-inflammable ducting.

Bi-flex INC Ducting is manufactured from steel rings covered with aluminized asbestos fabric lined with Neoprene and is suitable for conducting hot or cold air, gases, fumes, dust or airborne particles at low and medium pressures. Its high flexibility enables any bend to be made without kinking and effectively absorbs all mechanical vibration. The ducting can be compressed to 50 per cent. of its original length and in addition to its incombustible nature it will resist



● The Royal Dublin Society chose gas for its new sales ring at Ballsbridge. Our picture shows part of the interior of the sales ring.

THE R.D.S. CHOSE GAS HEAT

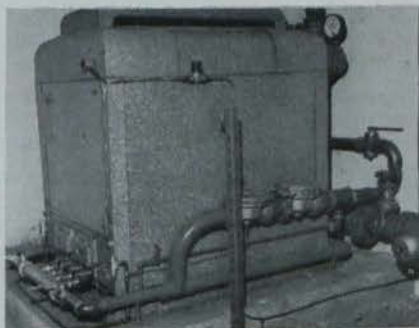

● The No. 3 series Rex Potterton gas-fired boiler, 625,000 B.t.u./hr., installed in the R.D.S. Grounds at Ballsbridge for heating the 36 panel radiators in the new sales ring. It is one of the most up-to-date small bore central heating systems in the country and was installed by the Dublin Gas Company.

moisture, vermin, mould and fungi. Bi-flex INC Ducting is suitable for operation at temperatures from -40°F to $+200^{\circ}\text{F}$. Supplied in standard 10 ft. lengths with I.D.'s ranging from 3" to 14", it is extremely light and easy to handle and easy to cut to length.

* * *

A NEW combination fan and limit control for forced air heating systems has been introduced by the Residential Division of Honeywell Controls Limited.

HONEYWELL FAN/LIMIT CONTROL

This quality control turns a furnace fan on and off at adjustable pre-set

temperatures and also incorporates a high-limit shut-off to turn off the furnace if the plenum temperature goes too high.

The new control features push-in terminal connectors for fast low-cost wiring; independent settings for fan-on and fan-off temperatures and choice of $\frac{1}{2}$ or 1-inch diameter insertion tubes in 5, 8, or 11-inch lengths. Additionally, it features a 14 ampere heavy-duty snap-action switch, contacts of which are suitable for line or low-voltage circuits or Powerpile (millivolt) systems.

In operation, the control turns the

Continued overleaf



fan on when the plenum temperature rises to a pre-set point, turns it off as the plenum temperature drops to another pre-set point. The limit switch breaks the flame circuit if the plenum temperature goes too high.

* * *

TWO further series of suspended gas fired unit space heaters—the XB and XC — are now being produced by the Reznor Nesbitt Division of I.T.T. Industries Ltd. (Connaught House, Aldwych, London, W.C.2).

The XB range of 12 different sizes, from 50,000 to 400,000 B.t.u./hr., is basically similar to the XA propellor fan series introduced in October, but is fitted with a Torringtons centrifugal blower. This air moving unit is designed for commercial applications where a very low noise level is important.

The XC version is even quieter for it has a matching sound-proofed insulated cabinet enclosing the centrifugal blower. Both the XB and XC series are particularly suitable for churches, hospitals, supermarkets, restaurants and offices.

* * *

FUEL units which enable pressure jet oil burners to use inexpensive heavy fuel oil (200, 950 and 3500 Redwood No. 1) are now being produced by Lee, Howl & Co. Limited (Tipton, Staffs.) under their licence with the Webster Electric Company of Racine, U.S.A.

NEW PUMP HANDLES HEAVY OILS

There are two models, types 1RR and 2RR both for 50 cycle speeds. The former is for single pipe gravity installations and for two pipe installations where the suction does not exceed 10 inches Hg vacuum (25, 4 cm.), and the latter is for two pipe systems not exceeding 20 inches Hg vacuum (50, 8 cm.). With type 1RR conversion from single to two pipe operation for tanks up to 10

INAUGURAL IHVE MEETING



● Pictured at the inaugural meeting of the Irish Sub-committee of the Institution of Heating & Ventilating Engineers were (from left to right): Professor Patrick Leahy, Professor of Mechanical Engineering, University College, Dublin; Mr. H. C. Jamieson, Past President of the Institution of Heating and Ventilating Engineers; Mr. Thos. Illingworth, chief engineer of the Heating Division, Office of Public Works; Mr. Eoin Kenny, hon. secretary, Irish Sub-committee.

Irish sub-committee hear paper on heating costs

THE Irish Sub-committee of the Institution of Heating and Ventilating Engineers held their inaugural meeting in Dublin earlier this month. The formation of an Irish Branch of the Institution of Heating and Ventilating Engineers had been under discussion for some time. A meeting was held last summer in Belfast at which it was decided to set up two centres pending further examination of the position—one in Belfast and one in Dublin. About three to four papers a year were visualised in each centre, some papers being read at both centres and some at one centre only.

The inaugural meeting of the Dublin group was held in the Chemistry Theatre, University College Science Building.

Mr. T. Illingworth, A.M.I.H.V.E., A.M.I.E.E., F.I.E.S., read a paper, "A Survey of Heating Costs," at the inaugural meeting of the Institution.

The paper covered the development in the use of meteorological data and the introduction of the synthetic year for the assessment of the seasonal load on heating systems and the practical use thereof in the estimation of running costs.

The performance efficiency of various systems of heating under different operating conditions was investigated from a practical point of view and examples were quoted.

Financial efficiency as applied to heating was defined and examples were given based on practice showing the effect of capital expenditure, sinking fund, maintenance, attendance and similar charges on final running costs.

The calculation of a cost factor based on the consideration of both performance and financial efficiencies and the application of this cost factor in the calculation of running costs for various installations, was investigated and the results obtained thereby were compared with practical experience.

feet (3 m) beneath the fuel unit) is simply accomplished by the insertion of a bye-pass plug.

The filter is self-cleaning, and it is claimed that the fuel unit itself is very silent. Fitting to a burner is simplified because of a 360° port arrangement. Either unit may be used on a one pipe or two pipe system. The speeds are 1450 rpm or 2900 rpm, and rotation is in either direction. Maximum pressures are 150 p.s.i. or 300 p.s.i. (10, 5 or 21 Kg/cm²).

HENDRON BROS. (Dublin) Ltd., of Broadstone, Dublin, have been appointed agents for the Republic and Northern Ireland for Dustraction Ltd., one of the biggest firms in England specialising in dust and fume control. The firm operates from Oadby, Leicester.

HENDRONS GET NEW AGENCY

**INDUSTRIAL SECTION
CONTINUED PAGE
TWENTY-SEVEN.**

Northern Ireland monthly review

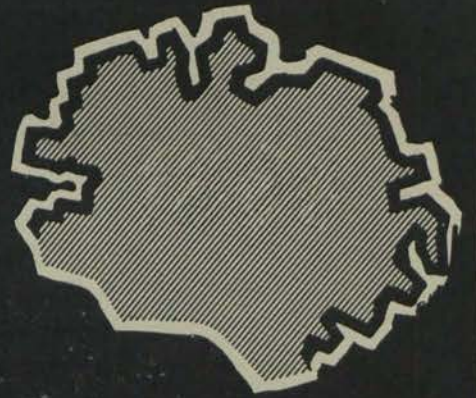

Oil

*The
most
economical
fully automatic
fuel for
CENTRAL HEATING*

Northern Ireland enquiries to:

SHELL-MEX AND B.P. LTD, 6 MURRAY STREET, BELFAST 1. Tel: 20881

Republic of Ireland enquiries to:

IRISH SHELL AND B P LTD, SHELL-B P HOUSE, 13/16 FLEET STREET., DUBLIN 2. Tel: 72921



PRESIDENT'S MESSAGE

It gives me great pleasure to say "thank you" to "The Irish Plumbing and Heating Engineer" for their timely anticipation in deciding to give a more comprehensive coverage in their journal to the trade in Northern Ireland. I do trust that they shall be rewarded by getting all the help and co-operation needed to make their efforts a success.

*Signed: W. H. TANNER,
President, Plumbing & Heating Employers' Association.*



**Bill Maginnis
Talking . . .**

Davidson open an apprentice training centre

A new apprentices training centre, officially opened by Davidson & Co. Ltd. (Sirocco Engineering Works, Belfast) last month, provides a strong link with the man who founded the Company in 1881—Sir Samuel C. Davidson, K.B.E.

The centre was provided by relatives of Sir Samuel, and was opened by Mrs. K. Hadow, M.B.E., a director, and daughter of the founder. At the ceremony the third generation of the family was represented by Mrs. John Bleakley, Miss Doreen Maguire and Mr. E. D. Maguire, whilst the fourth generation was represented by two of Sir Samuel's great-granddaughters, Miss Heather Bleakley and Miss Penelope Maguire.

Equipped with up-to-date machinery, the new centre will cater for craft apprentices, who will re-

ceive one year's theoretical and practical training before entering the works to complete the apprenticeship. The boys will be instructed in the use of the basic tools and in the techniques of their trades, and will be taught to operate machines similar to those employed on the production lines.

● Mr. Samuel Stewart, Northern Ireland, agent for F. H. Biddle Heating and Ventilating Equipment, has now formed a limited company. It is called S. Stewart (Thermal Engineering) Limited, 26 Neills Hill Park, Belfast 5.

Osma addition

OSMA Plastics Limited recently announced an addition to their building products (rainwater goods) range—the OSMA PVC gutter support bracket.

Injection-moulded from Polyvinyl Chloride the one-piece bracket is designed as an intermediate support for use with Osma 4½" Half-round Gutter. It is pre-drilled for immediate and simple fitting to the fascia.

● Our picture—held over from last month—shows (from left): Mr. H. H. S. Mansfield of John Harper & Co. Ltd., and Mr. W. Finucane, of W. Finucane & Co. Ltd.—agents for the Irish Republic—discussing the Harper Meehanite oil-fired boiler with Mr. Dugald Macfarlane, a director of the new Northern agents. They were attending a highly successful cocktail party given by John Harper & Co. Ltd., when they announced the appointment of P. & D. Macfarlane Ltd. as their N.I. agents for the Meehanite boiler range.



MAY I take this opportunity of wishing all our readers a very happy and prosperous New Year. During the coming year I hope to give a comprehensive coverage in as much detail as possible of the plumbing, heating and air conditioning fields here in Northern Ireland and I do ask for anyone in this field requiring assistance through this column or information for it to get in touch with me.

Commencing next month, I intend running a series on different personalities in the industry, which will include both the manufacturing and contracting sides.

During the past month the business side of things has been more or less forgotten and instead we were in party mood. The Institute of Fuel were first with their annual dinner in the Midland Hotel and I must here congratulate my colleague, Eric McBride, who is the local secretary of the Northern Ireland Branch. From all corners I hear that it was a roaring success. Then we had the Heating and Plumbing Employers' Association Annual Dinner in the Conway Hotel. This was so ably presided over by Mr. W. H. Tanner, who welcomed the various guests.

A large gathering attended at the New Technical College, Millfield, Belfast, to hear a lecture on "Dust Collection from Shell Boilers," by E. D. Maguire, M.A., M.I.Mech.E., Chairman of Davidson & Co. Ltd. I must congratulate him on one of the most interesting and successful lectures I have attended for some time, on a most difficult subject.

Continued page twenty-six

TECHNICAL SERVICES AND THE HEATING INDUSTRY



By

F. R. McBRIDE, A.M.I.Mech.E., M.Inst.F.

FOR some years the Heating Industry, both those connected with design and installation, have had available to them technical services from various sources and for the same period many concerns have adopted a most sceptical attitude towards these services.

It is in an endeavour to explain the attitude of the sponsors of technical assistance that this article has been written.

Initially it will be agreed that within the last few years the installation of equipment has become increasingly more complex as indeed has the equipment itself.

One cannot expect the designer in the heating consultant's office or the buyer or site foreman of a contractor's organisation to be experts in all fields of his industry; similarly he cannot be expected to keep pace with new

developments, for if this is to be done it would mean reading all the technical press and papers which in itself would become a full time occupation.

Before the war the tendency of those firms supplying equipment was to do their selling through agents, who possibly carried half a dozen associated products; however, the practice now is for representation to be carried by representatives who do not carry any more than a couple of products.

This scheme of selling as suggested above has in itself been found wanting and this has resulted in the representatives being supported by their Companies Technical Services.

It is regrettable that very often the

consulting engineers and contractors only decide to contact the Technical Representatives once things start to go wrong. If, on the other hand, a decision had been made at the pre-erection stages to seek advice everybody's time and money may have been saved.

The main benefit which can be gained by going back to the Technical Services Department of a supplier is the fact that the staff of these departments are in constant touch with their customers in Great Britain and each day they are meeting a new problem and in so doing they gather an immense amount of experience in their products which it would take the customer years to gather.

The people who have possibly put more time and money into developing Technical Services are the Fuel Distributors—Solid, Liquid, and Gas, Nationalised, Private and Public Authority, and though fuel is the power of the heart of all heating installations, possibly these Technical Services are used least of all.

Time and again breakdowns occur and it is not unusual for the blame to be laid initially, though possibly incorrectly, with the fuel, and it is then that the Technical Services of the Fuel Distributors are called upon. The completion of the survey will possibly result in the fault being traced to a faulty means of fuel storage, poor chimneys or a breakdown in the electrical control gear, and it is also probable that if advice had been taken earlier at least the first two reasons for the breakdown could be avoided.

The storage and handling of fuel both liquid and solid is not quite as simple as some people are prepared to think. As regards solid fuel, if thought and preparation is given to its

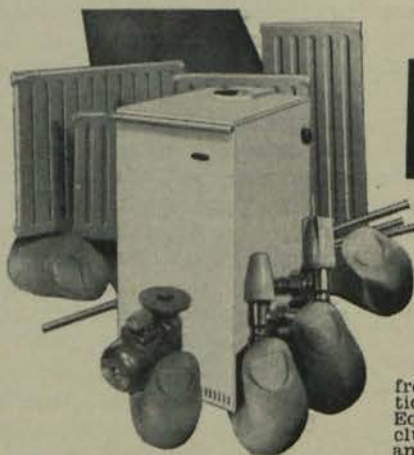

OBC
LIMITED

can
supply

from BELFAST, a vast selection of Central Heating Equipment and Spares, including: Oil Fired, Gas Fired and Solid Fuel Boilers, Circulating Pumps, Mixing Valves, Copper and Steel Tubing, Fittings, Fire Valves, Thermostats, Time Switches, etc.

Boiler Accessories, Radiators, Radiator Valves, Tanks, Circulating Pumps, Mixing Valves, Copper and Steel Tubing, Fittings, Fire Valves, Thermostats, Time Switches, etc.

Amongst leading makes stocked are POTTERTON BOILERS AND RADIATORS, IDEAL AND CRANE SOLID FUEL BOILERS, STELRAD RADIATORS, SATCHWELL AND DANFOSS CONTROLS, SANGAMO TIME SWITCHES, ETC.

Send now for the O.B.C. catalogue
Ireland's **LARGEST STOCKISTS**

and Distributors of

CENTRAL HEATING EQUIPMENT

Contact **O.B.C. LIMITED**

Manager: Mrs. A. Burnisan

23/27 CUPAR STREET, BELFAST 13

Tel.: BELFAST 31576/7/8

Head Office: **VINES LANE, DROITWICH, WORCS.**

Telephone: Droitwich 2551.

from previous page

A phone call could have saved pounds

storage, it will probably, particularly in the middle sized range of plants, eliminate all human handling and involve the client in little or no extra expenditure.

Equally often visits are made to solid fuel installations to discover that the wrong fuel has been specified or, what is more common, a type of automatic stoker has been selected which will require the more expensive grades of fuel, whereas a telephone call could possibly have saved the customer many pounds per year in running costs.

VISITS to oil fuel installations disclose storage tanks set at incorrect levels, tanks without sludge cocks, vent pipes and level indicators.

Tanks in exposed conditions cause certain grades of oil to wax and thus the burner commences to cut out. One visit from the fuel distributors' representative would have eliminated the trouble at the start.

It is particularly in the field of the small industrial installations that the advice which is obtainable could be of help to those of the heating industry, as, coming into contact with so many such installations, the Technical Services Engineer gets to know the "habits" and "idiosyncrasies" of various boilers, stokers and burners.

IN conclusion the writer believes that if the consulting engineers, heating contractors, design and installation staff made more use of the free services which are available to them there would be less complaints about the money being lost in giving after sales service; better jobs would result and happier clients would possibly pay their accounts sooner.

The fact that the services are "free" should not as present be held as a stigma indicating a bias. The reason the services are free is so that the suppliers of either the fuel or product commence a contract with the correct products in the correct place and then, all things being equal, it should give

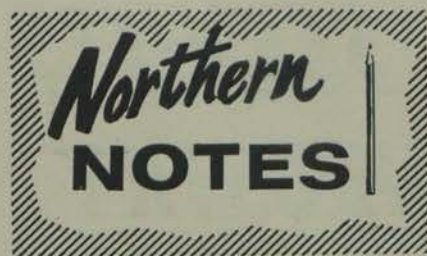

Extensive use of insulation in new plant

TO MEET the steadily increasing demand for Carling lager, the Ulster Brewery Company Ltd., of Northern Ireland, have spent three years making extensive additions and alterations to their brewery at Glen Road, Belfast. Widespread insulation has been carried out in many parts of the plant by Newalls Insulation & Chemical Company Ltd. (Sydenham Road, Queen's Quay, Belfast).

New glass beer tanks have been installed in three specially constructed conditioning rooms to increase output and keep up with the demand, and Newalls have insulated the walls and ceilings of these rooms with cork slabs.

They have also carried out the insulation of a series of large square fermenting tanks, and two yeast rooms, as well as hot liquor and methanol tanks. Extensive insulation work has been undertaken on pipework carrying beer, ammonia and methanol, and Newalls were also awarded the contract for lagging the new boiler and associated steam piping.

* * *

OBC and Potterton

O.B.C. LTD (Droitwich) have announced that their Northern Ireland branch has been appointed official distributors for the well known Potterton range of boilers, which includes the BOA and DOA oil fired and Diplomat gas fired boilers and the pressed steel panel radiators.

As a result the company have considerably increased their stocks of boilers and have recently put in a stock of radiators at their premises at 23 27, Cupar St., Belfast 13.

* * *

Frenger presentation

FRENGER Ceilings Limited held a presentation luncheon, attended by about 20 distinguished guests, at the

Woodbourne Hotel, Suffolk, last month on the occasion of the retirement of Bill Johnston, who opened their Belfast Branch 12 years ago.

It was explained that he would continue with the firm on a part-time basis, calling on many of his old friends on their behalf.

* * *

Hull's new agent

HULL Steel Radiators Ltd. (Hedon Road, Hull) have appointed Potter, Cowan & Co. (Belfast) Ltd. (114/122, Henry Street, Belfast 15) as their main distributors for the whole of Northern Ireland.

Under this arrangement, Potter, Cowan & Co. Ltd. are carrying large stocks of Hull Rad radiators in sizes consistent with the normal demands of the market.

* * *

Mixing valves

HOT and cold water mixing valves for showers, wash-basins, etc., are now manufactured in two different types by Meynell & Sons Limited (Montrose Street, Wolverhampton).

The first type is the Thermostatic "Meynelmix" hot and cold water mixing valve which, the manufacturers claim, has an extremely sensitive reaction to any variations in water temperatures and pressures and enables the user to take a shower in comfort and safety. This mixer will operate on pressures as low as 5 ft. head, and within a pressure ratio of 5 : 1 on the incoming services. Meynelmix Thermostatic shower valves are attractively styled and are ideally suitable for shower cabinets or larger installations in hospitals, institutions, etc.

The second type is the manually operated mixing valve, manufactured to BSS.1415, which operates through a sequence of Shut-Cold-Tepid-Hot, and provide temperate water by finger tip operation. A feature of this valve is that either top or bottom outlet can be fitted as required, and furthermore hot or cold supplies from either sides can be accommodated. This mixer is attractively styled and chrome plated in two sizes.

* * *

● MRS. Malinda Morrison, a Belfast housewife, won the Belfastgas Clean Air Competition which was run in conjunction with the clean air exhibition in the Wellington Hall. Her prize was a Debonair gas fire—installed free by Belfastgas.

AN INTERESTING WARM AIR HEATING INSTALLATION HAS RECENTLY BEEN COMPLETED IN THE NEW LUXURY HOME OF MR. DENNIS GINNIFF, AT NEWTOWN-BREDA, BELFAST.



PROVIDES WARM AIR TO DUCTED SYSTEM DOMESTIC HOT WATER TOO

THE oil fired warm air system in Mr. Dennis Ginniff's new home was supplied and installed by Messrs. Wm. Brennan & Sons Ltd., Heating Engineers, of Belfast. An Afos 150 Solo fully automatic oil fired heater was chosen, with an output of 150,000 B.t.u./hr. The necessary ductwork and grilles were supplied by the airheater manufacturers in accordance with drawings which had previously been prepared by their design and application department from the architect's house plans. Working drawings were also prepared for the installation to enable the entire system to be quickly and easily installed when it arrived on site.

The airheater itself is designed to provide warm air to a ducted system and also domestic hot water. This is obtained by a water jacketed combustion chamber from which flow and return connections connect to an indirect cylinder. Ample hot water is provided in this way and a towel-rail or radiators may be included if required. Air is circulated by a quiet low speed fan which delivers it to the supply grilles in the rooms throughout the house after having passed in through a filter and heat exchanger in the airheater unit, and an evaporative humidifier is also fitted. The oil burner is of the fully automatic pressure jet type and the unit can be arranged to provide hot water only in summer, or, alternatively the fan may be used for ventilation purposes; time switch and room thermostat control are installed.

As well as supply grilles, return air grilles and ductwork are provided for the lounge, livingroom and playroom. This permits a controlled recirculation to the inlet side of the air heater. Recirculation from the bedrooms is achieved by means of "no sight" grilles positioned above the doors, these grilles allowing the pass-

age of air without permitting light to penetrate from or into the corridor; the air is then drawn to a main grille which is situated at the end of a return duct to the inlet side of the airheater.

The grille boxes, which are fitted in the walls, are each provided with an internal damper for "balancing" the system, in much the same way as a lockshield valve is used on a radiator. Once adjusted this damper remains in a fixed position but the grilles themselves have easily adjustable hand control dampers for individual settings.

During installation the sheetmetal ductwork is easily installed as slip joints are provided and all branches and bends and connections are fitted together as shown in the installation drawings; they are then taped to prevent air leaks. The grille boxes arranged

for side wall fixing have a finish which permits plaster to be applied directly to them and wooden grounds are provided for the grilles to be screwed in to position when the job is completed.

The ducts are insulated with expanded Polystyrene sections taped in to position. The photographs of the heater unit shows how it has been cleverly positioned in the house so that it is completely out of sight in a heating chamber similar to a built-in cupboard. The photograph is taken with the two doors of the heating chamber open and it is easy to see that the unit is readily accessible for maintenance of the filter, humidifier and oil burner. Combustion air is fed through a duct into the heating chamber from outside the house.

Architects were Messrs. Brodie & Hawthorne, A.A.R.I.B.A., of 41 Malone Road, Belfast 9. Agents and Technical Representatives of Messrs. Afos Ltd. are Messrs. P. & D. Macfarlane Ltd., 23/27 Cupar Street, Belfast 13.

CENTRAL HEATING

WITH THE FAMOUS

'All-Around' Grate Boiler



The Willis "All-Around" grate boiler is the most powerful grate boiler on the market—proof of this claim is to examine the design—the boiler fits "All-Around" any open fire, giving a larger heating surface than any 'Back' boiler—ask your merchant, he knows.

HEATS 3-4 RADIATORS PLUS PLENTY OF HOT WATER—FROM ONE OPEN FIRE.

Made in Belfast by WILLIS, the Name Famous for 40 years in Open Fire Heating.

Write now for details to: Wm. Willis & Co. Ltd., 23/9 Dublin Road, Belfast, 2.

THE CLEAN AIR ACT AND THE HEATING INDUSTRY DISCUSSED

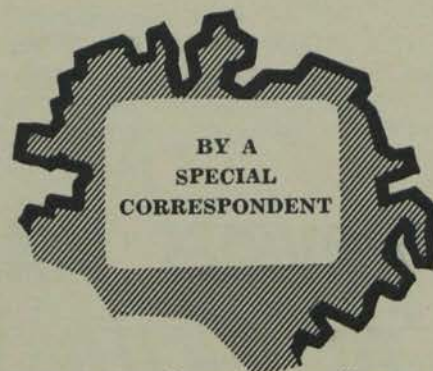

WITHIN the last few months the Clean Air Act (N.I.), 1964, has found its way on to the Statute Books.

While there has been much general publicity regarding Clean Air, and in fact a very successful Exhibition dealing with this subject was recently held in the Wellington Hall, Belfast, little or no information has been made available as to what part the heating industry will play in the implementing of the Act.

The first paragraph of the Bill states "that dark smoke shall not be emitted from a chimney of any building and if any dark smoke is so emitted the occupier of the building shall be guilty of an offence." This statement in itself clearly indicates what the legislation sets out to do.

The Act now being law, it is up to Local Authorities to define an area where they want "smoke control" to be enforced and to then make application to the Ministry for Health for approval to apply the legislation to all industrial and domestic premises within that area.

It is at this stage that the heating industry comes into the picture.

Let us consider first industrial premises which may be committing a nuisance. On receiving notification from the local authority that a smoke control area is now being planned, they must decide what action is to be taken. If the smoke is coming from an old hand fired boiler plant they may decide to fit automatic stokers or oil firing equipment. However, they may decide that since money has to be spent why spend it on an out-dated plant, therefore a decision may be made in favour of a new fully or semi-automatic boiler plant. Financial aid will not be available for such a modernisation under the Clean Air Act when the modification is made for the sole purpose of complying with the Act; however, financial aid will be available at the usual terms under the Capital Grants scheme.

If a decision is made to install a new plant this must comply with the new legislation; for example every

emission of grit and dust by the fitting of collectors.

The writer would at this stage suggest that a heating engineer, knowing that the legislation is now available for enforcement and knowing full well that public opinion will call for an early announcement as to where the first control areas are to be, should from now on when installing new plant ensure that it complies completely with the new requirements. It is also suggested at this stage that each concern should obtain from the Government Stationery Office a copy of the legislation.

Assuming that the boiler plant has been modernised or that a new plant has been installed and in the case of the latter a new chimney is required: Section 10 of the Act declares that "where it is proposed to erect a chimney for carrying smoke or grit and dust or gases plans for that chimney (showing also where it is to be erected) shall be submitted to the local authority for their approval for the purpose of this section." Later in the same section it is stated "that the Local Authority shall not approve plans submitted to that authority pursuant of this section unless they are satisfied that the height of the chimney as shown on the plans will be sufficient to prevent so far as practicable the smoke or grit and dust and gases from becoming a nuisance or prejudicial to health having regard to"—certain stated conditions. So it can be seen that a heating engineer would be well advised to make sure that his client has made the proper applications and that the proposed installation will meet the requirements of the Authority.

There has been a tendency by architects of recent years to look upon the chimney as something which had to be concealed within the structure and in their eagerness to do this they forgot about its functional purpose, consequently many of the chimneys of the new factories and schools are much too low and the cross sectional area has no relationship to the volume of gas to be carried.

It would appear therefore that in

some respects the new laws will result in more thought being given to chimney design and better chimneys will be the result.

Let us now examine the changes which will take place in the domestic field of the industry when a smoke control area is announced. It is highly probable that such an announcement in a thickly populated area will lead to orders for central heating being placed to such an extent that the resources of the industry may be taxed.

The success of the closed stove or room heater has been a revelation and the writer expects that when the public have to replace their open grate with one suitable for burning smokeless fuel they will decide to fit a closed stove and have a degree of central heating; in addition it is highly probable that they may replace their existing back boilers with newer high output boilers again coupled with radiators. The use of smokeless fuel will overcome the cleaning problems associated with some of the high output boilers and these will most likely find renewed favour with the public.

It is probable that with this development the more progressive firms will employ a grate setter to ensure the correct fitting of these boilers and room heaters, thus reducing service calls.

The householder will receive proportional grants from the Local Authority when he has to replace his fireplace to comply with the Act and these grants, coupled with the many forms of loans available, will lead to a considerable interest in central heating of all forms.

It is natural to expect that the oil, coal, gas and electricity industries will all be bidding for shares of this market and this being so it is suggested that it may be worthwhile some of the heating concerns developing the electrical sides of their business, so that they will be able to quote freely for whatever the customer may choose.

The introduction of the Clean Air Act and its implementing by Local

STOP PIPES FREEZING

NOW is the time to ensure 100% FROST PROTECTION

Even thorough lagging will not stop pipes freezing in extreme temperatures. But so long as ordinary main's power is available nearby, Isotapes will give 100% protection. Installation is quick and simple, needing only minimum lagging; thus overall cost is very reasonable. Power consumed is negligible—the more so when an Isopad thermostat is used—and they will last for years.

Isotapes for frost protection have an electric heating element protected by a robust plastic cover, with connections at one end only. It is traced below or wound around the pipe, then lightly lagged. It gives off a gentle heat just sufficient to keep the pipe and contents above freezing point. Made in many standard lengths and for various temperatures they are fully described in catalogue ITA/64, a copy of which is yours for the asking. Manufactured by world leaders in electric surface heating, Isotapes are made to exacting specifications. Expert advice is free and an experienced specification and installation service is available to the larger user.



ISOPAD LIMITED • BOREHAM WOOD • HERTS • Telephone: ELStree 2817 (6 lines)

Midlands: Tel: Hanbury 415 N. England: Tel: Horsforth 2511 Lancashire and Cheshire: Tel: Ringway 6467 Scotland: Tel: Glasgow City 4704
 Eire and N. Ireland: Tel: Belfast 612141 S.W. England: Weston-Super-Mare 2945 S.E. England and London: Head Office 1974A/FRO2

NON-STOP RELIABILITY

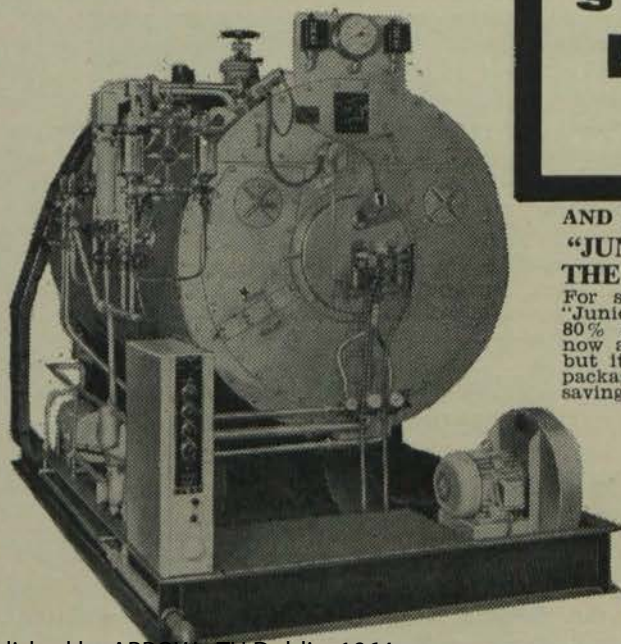

Cradley

STEAMPACKET package boilers

Install efficiency and economy — cut fuel bills — invest in the Cradley 'Steampacket' Package Boiler. It operates without constant staff supervision. The time - proven, smokeless oil - fired boiler gives larger evaporation and is over 80% efficient.

AND NOW—

"JUNIOR-STEAMPACKET" THE NEW SMALL BOILER

For small requirements the new "Junior-Steampacket" range of over 80% efficient Packaged Boilers is now available. The cost is lower, but it enables everyone to obtain packaged efficiency and space saving.

N. Ireland Representative:
G. W. MONSON & SONS

227 Beersbridge Road,
 Belfast, 5. Tel. 57823.

The Cradley Boiler Company Ltd.
 Cradley Heath, Staffs, Tel. Cradley Heath 66003.

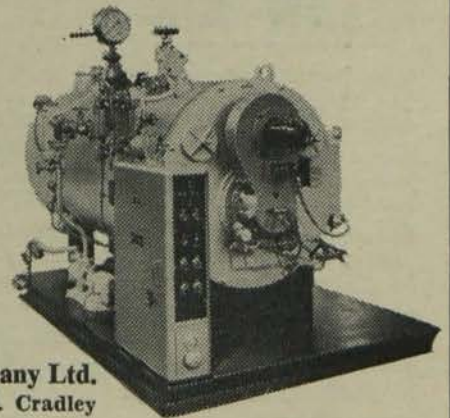

Bill Maginnis Talking . . .

from page twenty.

The lecture was organised by the local branch of the Institute of Fuel, chairman of which is S. O. Hicks, O.B.E., and the secretary F. R. McBride, A.M.I.Mech.E.

Danfoss Controls Ltd. have just announced the appointment of Mr. Jimmy Shields (late of W. P. F. Hume & Co.) as their Irish Representative, and may I take this opportunity of congratulating and wishing him luck in his new venture.

Now that the New Clean Air Act is about to become law, lots of people on my travels have been asking what it is all about. I don't wish to go into this subject too deeply as a special correspondent is writing a technical article on it for this issue, though I would like to say a few words on the subject nonetheless.

Over industrial towns the air usually contains small amounts of hydrogen sulphide, sulphur dioxide and dust. All these are products of combustion and of various manufacturing processes. The presence of this contamination in the air is a danger to health, contributes to the formation of fog and attacks building stone.

The situation had become so serious in Britain that in 1956 the Clean Air Act was brought into force. It sets quite strict limits on the amount of smoke and dust which may be set free by chimneys. As a consequence, it is now necessary to fit special equipment to chimney stacks to reduce to a minimum the amount of dust which passes into the air.

The Act is designed to combat this situation and every co-operation should be given to ensure the success of its important aims.

CLEAN AIR

from previous page

Authorities in Northern Ireland should hold no terrors for the Heating Industry; on the other hand, it may well become a challenge to its technical staff and to its productive ability.

It is probable that the first areas to be designated as Smoke Free Zones will be announced early in 1965, and so that they may be ready and be advised, the contents of the Act should be available in the design and manufacturing offices of all heating concerns.

Twenty-six

Big Night Out

recent events



● Pictured at the Annual Dinner-Dance of the Heating and Plumbing Employers' Association of Northern Ireland were (from left): President, W. H. Tanner; Miss M. P. McBriane; Mrs. D. Shanks; Mr. D. Shanks, President Royal Society of Ulster Architects; Mrs. E. Osborne and Mr. E. Osborne, Past President, Council of the Heating and Ventilating Contractors Association (London), who was guest of honour.



● At the Institute of Fuel (Northern Ireland Group) dinner were (from left): S. O. Hicks, O.B.E., Chairman; H. E. Crossley, Ph.D., President; and F. R. McBride, Secretary.

STICK WITH



"STAG"

THE JOINTING PASTE FOR EVERY JOINTING JOB

This is the most reliable medium for keeping joints tight when dealing with Oil, Petrol, Benzine, Acids, etc. Stag Brand remains plastic in the joint, is non-poisonous, insulating and anti-corrosive. Two grades available for good and rough surfaces.

Smail, Sons & Co. Ltd.

21 BRIDGEND, BELFAST

Telephone No.: BELFAST 51255.

DISTRIBUTOR IN EIRE:

James J. Doherty Ltd.

36 LOWER GARDINER STREET,

Dublin, 1

Telephone No.: DUBLIN 47927.



MONTHLY SPECIAL REVIEW

1 INDUSTRIAL BURNERS,
COMBUSTION EQUIP-
MENT AND STOKERS.

MANY ADVANCES MADE

COMBUSTION is a chemical reaction. When liquid or solid fuels are burned, the elements of which they are comprised unite with oxygen and new components are formed. The means used to burn fuel oil is the oil burner. The function of a burner may be very simply stated. It consists of breaking up the fuel oil into very small particles and mixing them with air so that they will burn while in suspension—the process being called atomisation.

Having broken the liquid into droplets, it is necessary to provide the air for combustion. In the case of the pressure jet burner the air is usually induced around the burner body by means of an air director, which consists of a series of slots or vanes through which the air is introduced into the combustion chamber close to the nozzle of the burner as possible. Good mixing of air and oil is then achieved.

With air or steam atomising burners a proportion of air or steam is passed into the burner body and mixes with the oil stream before entering the combustion chamber.

Burners are classified according to the method used to atomise the oil. The normal types in use are the following:—

- Vapourising Burners;
- Fan assisted vapourising burners;
- Pressure jet burners: (a) Spill jet type; (b) simplex; (c) fully automatic.
- Steam air assisted pressure jet burners;
- High pressure air or steam burners;
- Medium pressure air burners;
- Low pressure air burners;
- Rotary burners: (a) Air driven spinning cup; (b) Electrically driven spinning cup.

Combustion Equipment.

Measuring and recording instruments for boilers may be as simple or as elaborate as conditions or individual preference requires.

Proper instrumentation achieves much more than a mere safety factor for if the proper information is given

erly interpreted, one will have a clear picture of how the boiler is operating. Furthermore, maximum combustion efficiency can be maintained. Combustion efficiency can be influenced by many factors remote from the boiler or burner. In order to achieve this result pressures and temperatures must be indicated at a number of focal points in the system.

Fuel costs can be controlled by correct instrumentation of the system. Let us take one example. Temperature and pressure gauges are generally installed in the outlet line from the oil pre-heaters (whether steam or electric or combined), and in the oil circulating system in the burner.

Boiler efficiency is generally determined by three factors: (a) Fuel consumption; (b) Boiler evaporation; (c) Heat losses.

Fuel consumption is measured by means of an oil flow meter. An alternative, but not reliable or accurate, method is by means of an oil contents gauge. This latter is not sufficiently accurate for such a purpose.

Boiler Evaporation.—Steam evaporation is best measured by means of a clock type or otherwise steam meter. The actual steam evaporated from the boiler is recorded directly, though steam required for preheating the oil, steam used for an injector, blow-downs, etc., is not recorded. An alternative method is to measure the quantity of boiler feed water by means of a water meter or feedwater calibrated tank—this latter method being not 100 per cent. accurate. Boiler feed water temperature is a decided factor for calculating the actual evaporation.

Heat Losses.—The flue gases are the greatest source of heat loss from a boiler. These gases can be ascertained by the CO_2 content, the CO_2 being related to the excess air passing into the combustion chamber. The CO_2 content can be measured directly by means of a special recorder, either permanently fitted or taken occasionally by means of a portable indicator.

The choice of the type of instruments most suitable is governed by the size and layout of the boiler plant. A CO_2 indicator, smoke spot tester, flue gas thermometer, draught gauge and feed water thermometer and oil thermometer are basic requirements and are absolutely essential if efficiency is to be controlled properly and measured accurately. Instruments can be divided into two types—those of the indicating type which give immediate readings to the operatives, and those of the recording type which provide the operator with information over a period of time.

With the direct method of testing, the thermal efficiency of a boiler can be determined. The five measurements required are:—

- (1) Quantity of fuel burnt;
- (2) Quantity of water evaporated;
- (3) Working pressure;
- (4) Calorific value of fuel;
- (5) Feedwater temperature.

From the above readings the efficiency can be calculated as follows:—
 W = lb. of water evaporated per lb. of fuel.

H = Total heat in B.t.u. of 1 lb. of steam at average working pressure.

N = Sensible heat in B.t.u. of 1 lb. of feed water (temp. of feed water $-32^\circ F.$).

$C.V.$ = Gross calorific value of fuel in B.t.u./lb. boiler efficiency:
 $= W(H-h) \times 100\%$

C.V.

With the development of the modern solid fuel packaged boiler, the stoker is developed to such an extent that a boiler fired by solid fuel can be practically as automatic as the modern oil packaged boiler, though the problem of heat being generated from the deposits of fuel fed to the boiler still remains.

PRODUCT REVIEW—
See page thirty-one.



MONTHLY SPECIAL REVIEW

2 INDUSTRIAL BOILER
INSTRUMENTS AND
BURNER CONTROLS.

MODERN CONTROLS THE KEY

THE safety valve, which was the forerunner of automatic boiler controls, still continues to be one of the basic and necessary controls for hot water and steam boilers. In recent years complete control systems have been developed whereby the functions of the different controls are so interconnected that when they are properly maintained there is no need for human intervention. In our present "jet age" controls are now so standard, particularly on packaged boilers, that the boiler will start and stop itself. Such controls are operated by time devices, pressure devices and change in temperature. In this review it would be impossible to treat of even the standard necessary controls.

For the benefit of our readers, particularly those in charge of automatic packaged boilers, we will give a brief outline of the requirements that are necessary for automatically controlled steam boilers.

(a) Boilers fired with oil or gas. (i) Automatic water level controls should be such that they shall start the water-feed pump when the water level in the boiler drops, and stop when the water level in the boiler reaches a predetermined normal level, both normal low level and high level. Such controls may be operated by float, electrical probe or thermostat.

(ii) **Automatic firing controls** should operate so that they cut off the fuel supply to the burner when the boiler pressure rises to a set value, below the blow-off pressure of the safety valve. Generally when the water level in the boiler falls to a set amount below the normal low water level, an audible alarm should sound and lock out the burner. The control, preferably of the light sensitive type, should cut off the fuel supply to the burner in the event of flame failure, or in the event of failure of the spark or pilot ignition to ignite the fuel within a limited time. Where the water level

in the boiler is not perceptible (e.g., in coil burners), the controls should cut off the fuel supply to the burners in the event of the outlet steam temperature reaching a predetermined setting, flame failure or failure of the spark or pilot ignition to ignite the fuel within a limited time.

One of the most important controls on steam boilers is the "overriding control." This is a separate control, entirely independent to the boiler, where the water level is perceptible. Its function is to cut off the fuel supply to the burner in the event of low water at danger level, and operate an audible alarm. The control must be such that it must be manually re-set before the burner will start up—in other words the burner circuit is broken until the water level in the boiler is raised above the predetermined danger mark level. The manual resetting of the control may be arranged within the burner or stoker electrical circuit.

Boilers fired with Solid Fuel.—The automatic water level controls for solid fuel boilers are much the same as those used in the operation of boilers fired with gas or oil. Regarding the automatic firing controls, they should be such as to cut off the fuel and air supply to the stokers when the boiler pressure rises to a set value below the safety valve blow off pressure, and when the water level in the boiler drops below the predetermined normal low water level, an audible alarm should sound. Again, for the solid fuel boiler the "independent overriding control" must be fitted, as in the case of the oil-fired boilers.

The aforementioned safety controls are the minimum protection to the boiler. Additional controls are necessary and very essential, especially on automatic controlled boilers. Irrespective of the type of controls fitted to the boiler or their purpose, the safety controls should always override the controls fitted for the operation of the boiler, for efficiency and combustion conditions and they should be so designed and fitted as to provide complete safety upon the failure of the energy supply and they must be manually re-set. Explosion relief doors should be fitted to minimise any damage in such an event.

Flame Failure Safeguards.—Years ago the only protective controls for heat, power or process burners were the eyes and hands of the boilerman. With the introduction of automatic oil burners it became necessary to design controls to shut off the fuel and air supply if the burner flame failed to ignite during starting or if the flame went out while the burner was running. Without some flame failure protection, the firebox or combustion chamber would fill with explosive mixture of fuel and air and within seconds after the flame failed.

(a) **First: Anti Flooding Devices.**—The first flame failure was the pan below the burner nozzle to collect unburnt drops of oil. The weight of excess oil in the pan mechanically operated an oil shut off valve. This system hardly provided any safety.

(b) The next step was the development of the **Stack Switch**—heat actuated device. When the heat strikes a metal it expands. The Stack switch was in the form of a bimetallic coil inserted in the boiler stack. When the heat strikes the coil, the coil unwinds (expands) and operates a switch which permits fuel to flow to the burner as long as the coil is hot. When the flame fails, the coil winds up and opens the switch, thus shutting off the



BOTH THIS MONTH'S
SPECIAL REVIEW
ARTICLES WERE
COMPILED BY J. L.
FITZGERALD, B.Sc.

Continued page thirty.

BOILERS ?

BURNERS ?

DOMESTIC ?

INDUSTRIAL ?

We can offer almost any type you are likely to require from our range between 57,000 to 10,000,000 BTU's/HR. For oil-firing, solid-fuel firing or even dual-purpose firing.

Sole agents in Ireland for
NORAH boilers and ELECTRO-OIL burners.

Prompt deliveries. Competitive prices.

IRCO TRADING CO. LTD.

9 Eden Quay, Dublin 1

PHONE: 48277

NEW ARIC TANK CONTENTS GAUGE WITH REMOTE READING UP TO 100 FT.

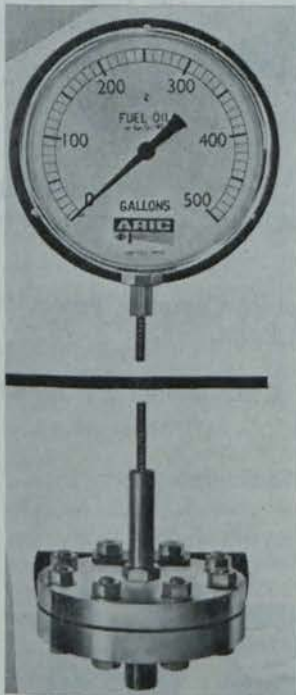

★ **YOU HAVE INSTRUMENTATION PROBLEMS OR REQUIREMENTS?**

Our wide range of ARIC Instruments cover all types of measurement and control of pressure and temperature.

★ **YOU HAVE INSTRUMENTS FOR REPAIR ?**

Why not call in ARIC and make use of our wide repair facilities here in Dublin.

★ **YOU HAVE INSTRUMENTS ON SITE THAT REQUIRE MAINTENANCE ?**

Our highly skilled outside maintenance unit can repair on site.

ARIC TRANSMITTING PRESSURE GAUGE WITH STAINLESS STEEL DETACHABLE DIAPHRAGM



ARIC (IRELAND) LTD., 6 MONTAGUE STREET, DUBLIN 2. TEL.: 53821/55510

The Irish Plumbing and Heating Engineer.

fuel to the burner. There were many other devices employed on this principle, i.e., diaphragms, delicate bimetallic strips, thermocouples, etc.

Their drawbacks were numerous; their action was too slow—taking up to five minutes to operate. Dirt and soot, etc., caused further delay in response to flame failure. Furthermore, the heat in the firebox and stack does not fall rapidly when the flame goes out.

(c) **Flame Rods and Photo Tubes.**—Instantaneous flame protection was developed to obtain more reliable protection. The first types were designed around photo tubes actuated by light from fire. They responded to yellow oil burner flame but could not “see” blue, nor luminous gas burner or pilot flame. So the flame rod was developed for gas flames. The rod is placed in the flame and depends on the ability of the flame to conduct minute electrical currents. These had their drawbacks as well. Flame rods were awkward to install; maintenance was costly, and they were gradually losing their sensitiveness to conduct current. Photo tubes are sensitive not only to yellow oil burner flame, but to red hot firebricks as well, creating a dangerous delay in shutting off fuel to the burner.

Foolproof Safeguards.—Fireye engineers invented the first completely successful flame failure safeguard which overcame all deficiencies of earlier controls. Fireye used a tiny photo-conductive cell that is sensitive **only** to the infra red radiation given off by a flame so that it can distinguish between flame and glowing refractory.

The Fireye flame failure protection equipment operates on the principle of monitoring a flame by detecting the infra-red emanation from that flame. It is an axiom that the infra red emanation from all flames, whether from oil, pulverised coal or all forms of gases, is at a periodicity of between 10 and 15 cycles per second, e.g. The Fireye safeguards will not respond to the infra red from sunlight nor from that of a 50 cycle incandescent lamp.

In brief, the Fireye flame failure safeguard consists of two units:—

- (i) The lead sulphide cell scanner which monitors the existence or otherwise of the flame.
- (ii) The control which registers the existence or otherwise of the flame and passes on impulses to initiate the establishment of safe conditions after flame failure has occurred.

SPECIAL REVIEW

from page twenty-eight

Reference might be conveniently and appropriately made here to the Fireye flame failure safeguard and programmer. This programmer is particularly applicable to single burner boilers and fully automatic spark ignited and pilot ignited main flame burners. The programmer was exactly the same form of lead sulphide cell, photo-conductive scanner as the controls referred to above. However, it incorporates a timer device which will allow of automatic programming of a boiler with safe light off procedure from cold start to on load conditions. It will also permit of safety shutting

down of the boiler when load conditions are so low as to warrant such shutting down. However, modulating controls are incorporated in the Fireye programmer which permit the use of convenient forms of automatic pressure control units to effect regulation of the packaged boiler output within the limits of its range of control between low load and high load.

On the subject of interlocks, Fireye flame failure safeguards are particularly adaptable in that conventional interlocks can be incorporated in the start circuit of the Fireye control unit to prohibit lighting on the burner or, after starting, to effect shut down of a burner if such interlock requirements are not met.

Tylors Flow Meters

Liquid Control at Low Cost

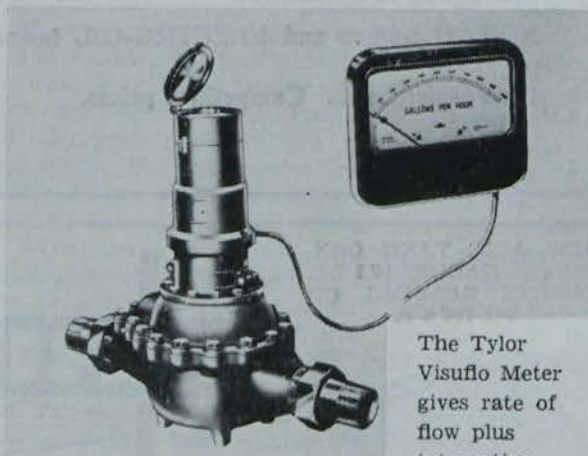

The Tylor Visuflo Meter gives rate of flow plus integration



● Tylors Model LL-3. Robust meter for oil-consumption in burners.

- ★ Blending and Batching of Industrial Liquids for Automatic or Manual Control.
- ★ Remote Control of Complete Processes from a Central Point.
- ★ Measuring Oil Consumption for Boiler House Plant.
- ★ Rate of Flow Indication.
- ★ Water Meters for all duties.

TYLORS



55 RATHGAR AVENUE, DUBLIN.

'Phone: Dublin 904603. 'Grams: "Tyland," Dublin.

The WF series of Oilheat Domestic Boilers from Henry Wilson & Co. Ltd., for use on closed circuit hot water heating systems only, are supplied in ten different models, ranging from Model 45/S (45,000 B.t.u./hr.) to Model WF 150/W (150,000 B.t.u./hr.). Five of the models are supplied complete with Wilson Water-guard controls, i.e., time clock, relay and plug-in contacts for room thermostat and cylinder thermostat.

The PJ series is available in four different models ranging from Model PJ 70 (70,000 B.t.u./hr.) to Model PJ 160 (160,000 B.t.u./hr.). The models have pressure jet type burners. The semi-automatic V series, Model V35 (35,000 B.t.u./hr.) has the short drum type of burner.

Wilson & Co. Ltd. also manufacture a range of Oilheat pressure jet conversion burners for converting solid fuel boilers to oil-firing. They include light and medium oil burners. The Oilheat boiler burner units are for use on closed circuit hot water heating systems, except when adapted for steam raising. These include the Cositube boiler series.

* * *

THE SERIES A1 Hartley and Sugden cast iron sectional boiler for water features a horizontal nozzle fitted with Butterfly damper, which is regulated from the front of the boiler. However, a vertical smoke nozzle, with check draught door, can be supplied if specially ordered.

The standard unit includes six 4-in. pipe connections up to 609 and eight 4-in. 610 to 613. Connections up to and including 5 in. diameter can be supplied. Flows can be fitted on any section except front and back.

All fronts are tapped 1½-in. for safety valve and 1-in. for draw-off cock, also for thermometer and altitude gauge. The average weight, including stand, is 9cwt. per section—approximately—empty. The pipe flanges and pads on sections are machined and joint made. The series can be supplied up to 16 sections (1,640,000 B.t.u./hr.) for oil fuel or mechanical stoking.

* * *

HODGKINSON Bennis Ltd. of Walden, Manchester, have recently completed the development work on an Underfed Stoker suitable for burning turf brickeens. The initial tests and subsequent trials have been conducted with the co-operation of Bord na Mona.

The first such machine was installed at the Gresham Hotel, Dublin, and was

1 PRODUCT REVIEW

In this equipment review we take a look at new developments in the fields covered by this month's first special review. (All claims are those of the manufacturers).

rated at 400 lb. per hour. An order has been placed for a stoker of similar capacity. Each is controlled by a Custodian Panel arranged to start an independent force draught fan motor fitted to the machine before the feeding of fuel is commenced.

Subsequently, in response to a signal from the pressurestat, the coal feed motor stops a minute or so before the fan. This system, which was pioneered by Hodgkinson Bennis for the burning of coal, is proving very satisfactory with turf brickeens.

* * *

ALLIED IRONFOUNDERS Ltd., Brook Street, London, have combined a normal low pressure hot water system for hot house heating based on two hot water boilers, with the facility to generate steam for soil sterilisation for a short period each year.

The Company's Heating Division built two Class 1 hot water boilers, of 3 million and 3.25 million B.t.u./hr. output, built to withstand 150 p.s.i.g. In addition to the normal control thermostats, and the hot water and flow return connections, a complete set of steam boiler controls are provided, and also a steam flow connection with crown valve and the usual feed and water pump and valve arrangement.

The control box is in two sections, with a single change-over switch. On one side is the hot water control, and on the other side control by stat, high and low water control and the usual steam boiler arrangement for unattended steam raising.

When in use for house heating, the boilers will operate through 4-way mixing valves, to maintain a return temperature in the region of 160 degrees F. This is most necessary during mild weather because the actual circuit return water temperature may well fall to 100 degrees F. or less.

When steam is required for soil sterilisation, the hot water connections will be closed, thermostats removed

(because of the high temperatures required) and the control change-over switch put to "Steam." The steam crown valve will be opened and the water level lowered. After putting power onto the feed-water pump, the boilers can be used to raise steam.

* * *

CORRIE, MacColl & Son Ltd., manufacture and distribute the Swiss designed Elco pressure jet oil burners. The range of burners is suitable for boilers with capacities from 45,000 up to 35,000,000 B.t.u./hr., and for fuel oils from 35 secs. to 3,500 secs. Redwood No. 1 at 100 degrees F. and the range includes models for on/off, high/low or fully modulating operation.

The Elco UD type burners now used more and more in boiler house plants are designed specially for high efficiency boilers with pressurised combustion chambers. They can be fitted to boilers with capacities rated from 500,000 to 6,500,000 B.t.u./hr.

Another type which is widely used in the industrial field is the Elco KA burner, which, apart from the burner head, has a separate fan, pump block and preheater. The advantage of this type of burner is its flexibility. For example, a special fan can be chosen to suit exactly the conditions of a particular site.

The Electro-Oil Series HT free-burning high pressure oil burner for light and heavy fuel oil is manufactured by B. Palm & Co., AB, Norrkoeping, Sweden. It is produced in three sizes (ratings) as follows: Series HT-1, HT-2, and HT-3, with capacities ranging between 2.9-29 US gph.

The burner is supplied as standard execution with a split burner tube, which is hinged in such a manner that by the simple extraction (by hand) of a pivot pin, the burner can be swung free from the boiler, exposing the complete burner head for ease of maintenance. Double pivoting of burner provides for either a right hand or left hand access. The series HT burner can be applied for either horizontal or vertical firing. The operation of the series HT burner is by the proven principle of circulating preheated fuel oil at a constant temperature through the ring pipe circuit on the burner.

This ensures that the circuit right up to the nozzle is at all times pre-flushed with warm oil before ignition is permitted, which results in instant ignition, clear smoke free flame, and rigid flame pattern. This is obtained by equipment designed and produced by the makers, and for which patent

Introducing...

Bentone-Verken, the most important oil-burner producer in Scandinavia, who this year will be putting some 40,000 oil burners on the market. This quantity is all the more remarkable when one considers that the total Swedish production of oil burners amounts to about 100,000 from over 30 different concerns.

Bentone-Verken employs an intensive research and development staff and are continuously engaged in producing new improvements in the construction of oil burners. The Bentone Burners, from the smallest domestic burner to the biggest industrial model, enjoy a well-earned reputation. They are very competitive in price as well as in use. The secret of the low running cost of the Bentone burner is the employment of a special principle in the burning apparatus by which an economy of more than 20% in oil can be obtained in comparison with the use of a conventional make.

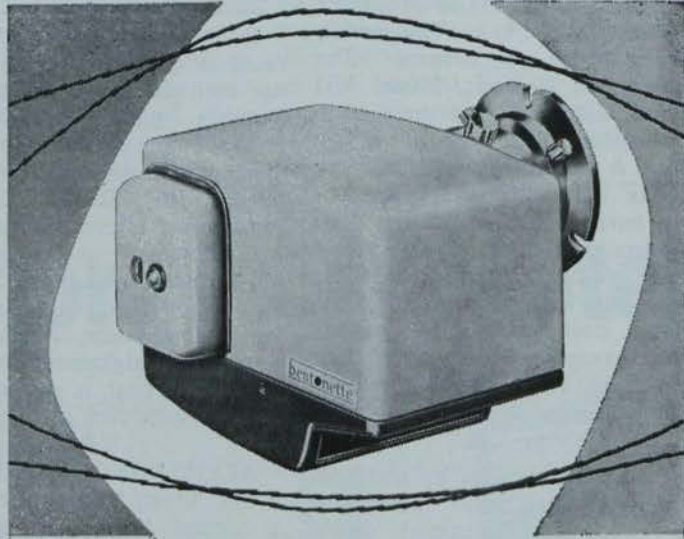

bentonette

a small oil burner rendering great service in a compact presentation with its high CO₂ rendering and the low quantity of soot. This is an ideal burner for any modern boiler.

Range: 60,000 - 180,000 BTU/hr. Bentonette models may be obtained with 'Buderus' as complete pre-wired package unit.

bentomin

a new small oil burner, which, like the "Bentonette", needs no refractory brickwork or combustion chamber, is highly effective and perfectly simple to install.

• Both the Bentonette and the Bentomin are equipped with photo resistor, relay and twin thermostat as standard. Range: 60,000-96,000 BTU/hr.

bentone

Light and medium burner. Type P and T, are intended for larger heating capacities of from 160,000 5,000,000 BTU/hr. As with the other models, they are free burning and either flange mounted or with swing doors.

Sole Representative:

ROBERT J. BURKE

4 Molesworth Street, Dublin, 2. Telephone: 77815.

b
bentone

AB BENTONE-VERKEN • SWEDEN

rights have been applied for. The agents in Ireland are the Irco Trading Co. Ltd.

* * *

DURING the past year G. C. Pillinger & Co. Ltd. developed and marketed a further version of their now well tried model PH oil burner, for use on 200 seconds fuel. All components on the burner are easily accessible for inspection and maintenance without disturbing oil or electrical connections. The burner covers a rating of 250,000 B.t.u.'s to 750,000 B.t.u.'s per hour.

* * *

THOS. HEITON & Co. Ltd. handle the Suxe solid fuel burners which have been selected for the completely automatic firing plant at the Dublin Vocational Education Committee's headquarters in Cathal Brugha Street. The versatility of the burners is well known as they have been used for both steam and hot water systems and with considerable success for both malt and grain drying. In this respect Heitons will be happy to place the complete facilities of its technical advisory and design departments at the disposal of consultants, contractors and plant operators, for the solution of their heating process or drying problems.

* * *

FRANCIA Pressure Jet Oil Burners, supplied by Irish Technical and Pro-

From page thirty-one

duction Co. Ltd., 25 Upper Mount St., Dublin 2, have a range of oil burners from 50,000 to 6,000,000 B.t.u./hr.

These burners are fully automatic and are supplied with photo-resistance controls, flexible oil pipe and automatic Stopair device. The 200 sec. oil burners are fitted with magnetic valves, and fuel recirculating at the start ensuring immediate starting. This is a change on last year's models and an interesting improvement.

All the burners are pre-wired, reducing the electrical installation to a minimum, and the electrical control box is the plug-in type. Models are available from 50,000 to 160,000 B.t.u./hr. (light oil) and 300,000 to 6,000,000 B.t.u./hr. (200 sec. oil).

* * *

THE NU-WAY Model Y-Com oil burner is designed for small metal melting furnaces, ovens, and heat process plant, and will burn cheaper medium-grade fuel oils. The unit, which externally resembles the conventional pressure-jet oil burner, is equipped with a special nozzle assembly using compressed air as the atomising medium. All components of the burner have been selected and assiduously tested for reliable performance over long periods under the most arduous industrial conditions.

The Nu-Way Y Com burner has a maximum firing capacity of 3.75 Imp. galls. per hour, standard models being intended for operation on light distillate oils. A special version of the burner, equipped with a miniature electric pre-heater, is offered to burn medium-grade fuel oils (up to 25 seconds Redwood No. 1 at 100 degrees F.).

* * *

THE Bering range of oil-fired heaters has recently been extended and improved. The exit louvres are now even more efficient on both floor-standing and wall-mounted models, it is claimed.

The semi-automatic range recirculates blown warm air to reduce efficiently both running and installation costs of heating warehouses, factories, workshops, etc. This recirculation completely warms such buildings within one hour.

An essential feature of the design is the sealed combustion chamber which discharges the products of combustion into the flue, this eliminating any possibility of carbon dioxide pollution. The maximum amount of heat is extracted by the blown air passing over this chamber and the heat exchanger.

Basic prices of the robust and durable attractive models start at £71, or £205 for the Fully Automatic 140,000 B.t.u./hr. model

CLYDE

HEAVY OIL BURNERS

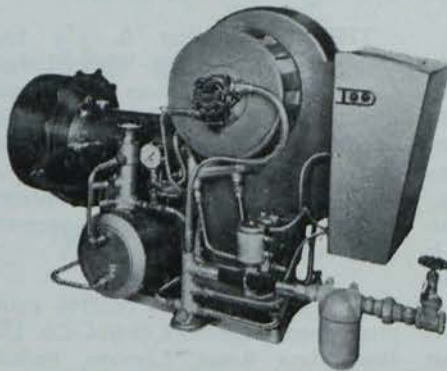

Clyde 'HOB' burners are suitable for heavy fuel oils and are fully automatic, easy to install, silent running with full safety controls. All high/low flame burners are supplied with 'COMPOSITE' combustion heads to give high combustion efficiencies with maximum turn down ratio.

6 BRANCHES THROUGHOUT IRELAND



You can now take advantage of six service branches in Ireland. Another addition to the extensive after sales network throughout Ireland.

CLYDE
tasso

CAST IRON SECTIONAL BOILERS

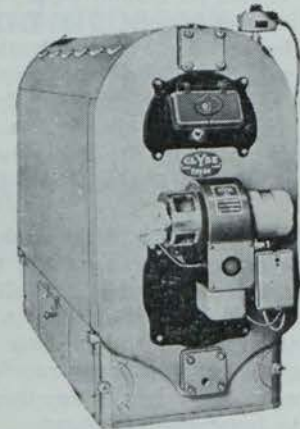

Clyde 'Tasso' fully automatic oil-fired boiler-burner units are available with ratings from 60,000 to 524,000 BTU's per hour. Also suitable for central heating and hot water systems are the range of Clyde 'Tasso' cast-iron sectional boilers with ratings from 60,000 to 2,575,000 BTU's per hour. Available for oil, solid fuel or mechanical stoker firing with operating efficiencies of approximately 80%

CLYDE FUEL SYSTEMS LTD.

80 Holywood Road, Belfast. Tel.: Belfast 65365/6.

Branch at Londonderry.

CLYDE FUEL SYSTEMS (IRELAND) LTD.

6 Mount Crescent, Dublin. Tel.: Dublin 66489.

Branches at Cork, Limerick and Longford.

The Irish Plumbing and Heating Engineer.

A NEW catalogue has been released by Venner Ltd., and those interested in receiving copies should contact Roper Bros. Ltd., Wholesale and Electrical Suppliers and Agents, 5 South Anne St., Dublin, who are agents in Ireland for the Company.

Roper Bros. report that their repair and overhaul service is being increasingly used, while the Venerette Time Switch, at £4 19s. 6d. list, less the new increased discount, is passing all sales records, and with new switches anticipated next year, the Venner range will be "most interesting."

* * *

A SINGLE-POLE, single phase 100-amp heating contactor has been added to the Enbray range of equipment. It measures only 5 $\frac{3}{8}$ " high by 3 $\frac{7}{8}$ " wide by 4" deep. Known as type 2Z4, it complies with B.S.775 Class IV. Category A1, and it is particularly suitable for controlling the larger off-peak heating installation.

Full control circuit terminals allow control by local time switch, thermostat, remote time switch (via pilot wiring, or via separate coil supply circuit. The instructions for making these various connections and a circuit diagram are moulded on the inside of the cover, which also has provision for sealing wires. The contactor has a neutral link and a control circuit fuse, with a spare cartridge in a housing in the moulding.

* * *

All products of E. N. Bray Ltd., Britannia Road, Waltham Cross, Herts., are available through their agents in Ireland, Messrs. H. A. Handcock & Co., 36 Dublin Road, Sutton, Dublin, and Messrs. J. & T. Ballantine (Belfast) Ltd., 11 Corporation St., Belfast 1. The subsidiary company of Bray Ltd., Messrs. Enbray (Ireland) Ltd., the first of its kind, is now manufacturing both of the above components at 8 North Frederick St., Dublin.

* * *

ROTHERHAMS Mini-Matic time controller for modern central heating is particularly suitable for all domestic central heating systems. A major advantage of the unit is that it can be set to carry out any required sequence of operations at any time from one to fourteen days ahead.

The Mini-Matic is supplied with either flush panel or baseplate surface mounting. For panel mounting the aperture required is 3 $\frac{7}{8}$ " x 2 $\frac{1}{4}$ ", the face and cover projecting just 1" from the panel, with all the setting controls

2 PRODUCT REVIEW

**I n this equipment review
we take a look at new
developments in the fields
covered by this month's first
special review. (All claims are
those of the manufacturers).**

When surface mounted, the overall dimensions are only 4 $\frac{1}{2}$ " x 3 $\frac{1}{2}$ " x 2 $\frac{1}{4}$ ".

FOR the return of Condensate to the boiler house, Girdlestone Pumps Ltd., Woodbridge, Suffolk, manufacture condensate recovery units as standard equipment and in special forms.

The range comprises sizes capable of handling return rates of up to 240,000 lbs. an hour, and with galvanised steel or copper receivers fitted with level controls, single and duplicate pumps and motor starters. They may be mounted on a fabricated base as a package unit or with a separate receiver and pump or pumps.

Girdlestone condensate recovery units are in use in Britain by most large steam users, such as Rolls-Royce Ltd., Richard Thomas and Baldwins Ltd., Scottish Malt Distillers, James Booth Aluminium, Milk Marketing Board, together with many hospital boards and Government departments.

The agents in Ireland for Girdlestone pumps and condensate recovery units are W. Finucane & Co., 5 Upper Pembroke St., Dublin.

* * *

A NEW short stem boiler thermostat, type GAB, has been marketed by Robert MacClaren & Co. Ltd., Eglinton Works, Kilbirnie St., Glasgow. The unit is designed for the temperature control of liquids and is particularly suitable where a sensitive instrument with a short length of stem is required, such as sectional boilers or pipe lines.

The patented switch mechanism is housed in a well designed diecast watertight enclosure with a graduated knob for external adjustment of the temperature setting. The GAB is available in two versions—a two-contact instrument to break circuit on temperature rise and a three-contact changeover instrument.

Both versions are supplied with a

$\frac{1}{2}$ " B.S.P. bronze pocket which makes it inter-changeable with other types of instruments for such applications.

* * *

THE KENT d.c. Oxygen Analyser is used to determine the oxygen content percentage in carrier gases and has particular application in combustion control schemes.

Continuous analysis is combined with minimum sampling-time lag and rapid response to changes in the oxygen content of the gas sample. Compensation for ambient temperature changes is automatic.

The d.c. output can be fed into a standard "Mark 3" or "KE" potentiometric recorder or into a standard "Mark 3" or "KE" potentiometric recorder or into a "Transdata" converter; multi-point recording, using a number of analysers, is greatly simplified.

The manufacturers are George Kent Ltd., Luton, Bedfordshire, England.

* * *

A NEW mercury-in-steel two-stage temperature controller with a 6" dial, model 1056—has been produced by the British ~~Rotherham~~ ^{Rotherham} Company Ltd. The instrument is a development of the Company's 8" two-stage controller. Although designed principally for use with electrical transformers, it is suitable for a wide range of industrial applications as the controller has a direct switching capacity of up to 10 amps at 230/250 V. A.C. without use of relays.

In addition to its application of temperature control, the instrument can be used to give visible or audible warning signals and a complete cut-off plant.

* * *

THOMAS Heiton & Co. Ltd., Dublin, represent the White-Rodgers Co. of the United States and Canada, manufacturers of modern heating, air conditioning, cooling, refrigeration and gas controls. A full stock is always carried and in addition prompt and efficient servicing arrangements are available.

* * *

A WIDE range of control equipment from Thermo Control Co. Ltd., Blackfriars Road, London, includes the Variator LU69 electronic weather compensated central unit, designed for use in hot water heating systems and operating with an immersion thermostat and ambient detector to control motorized circuit mixing valves. It is available with the series MT72, MT73, and MT74 Motorized Valves.

**compressed air
pipeline filters**

by

VOKES

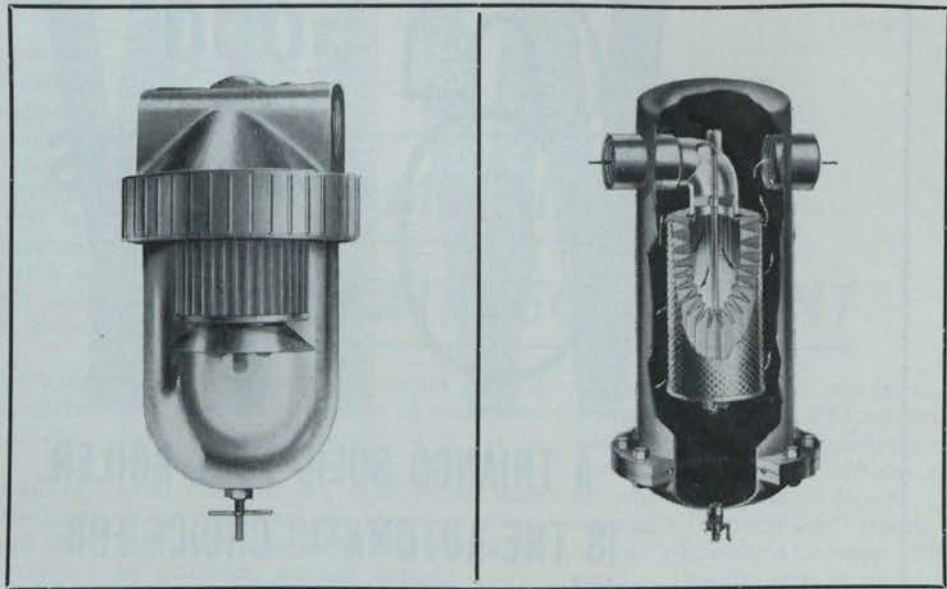

Vokes compressed air pipeline filters are available for vertical or horizontal installation in seven standard sizes to cover lines from $\frac{1}{4}$ in. to 4 in. and pressures up to 500 p.s.i. Custom built filters are also available to meet specific requirements. Vokes also manufacture a filter for use in $\frac{1}{4}$ in., and $\frac{1}{2}$ in. air lines fitted with a transparent bowl to enable the need for servicing to be quickly seen. Write for details.

THE LEINSTER ENGINEERING COMPANY LIMITED . 158-159 Church St., Dublin 3. Phone 77093/4

SUDDENLY . . .



You have made us the largest stockists of cast iron heating boilers and steel column radiators in the country . . .

. . . and you can make our stocks work for you . . .

★ For Heating In A Hurry

Telephone 693940 and 693943 Telegrams Halo Dublin.

QUADRANT ENGINEERS

167 STRAND ROAD, MERRION GATES, SANDYMOUNT, DUBLIN 4.



Sole Agents for BUDERUS Boilers and Radiators

6 Good reasons why

A TRIANCO SOLID FUEL BOILER IS THE AUTOMATIC CHOICE FOR THE MODERN HOME

- 1** A Trianco Boiler is thermostatically controlled. You set the thermostat, the Boiler does the rest.
- 2** A Trianco Boiler is gravity fed automatically with small anthracite from a large integral fuel hopper permitting burning for up to 72 hours without attention or refuelling.
- 3** The Trianco Boiler is declinkered in 2 seconds by a simple lever movement. (No dust, no loss of heat). This is a Trianco Exclusive Feature. The clinker and ashtray only requiring emptying once or twice a week.
- 4** The Trianco Boiler gives more heat for less fuel and burns a wider range of fuel than any comparable boiler.
- 5** A Trianco Boiler will provide central heating and constant hot water, cleanly, economically and efficiently.
- 6** A Trianco Boiler is attractively designed in a choice of colours and is a fine engineering product, made to give years of trouble free operation and backed by a first class service.

Trianco Solid Fuel Domestic Boilers from 50,000 B.t.u. capacities. Larger Trianco Boilers up to 3 million B.t.u. (oil fired) and 2 million B.t.u. (solid fuel).

TRIANCO

For further details write or phone our Trianco agents in Eire



BY APPOINTMENT TO
HER MAJESTY THE QUEEN
THE QUEEN MOTHER,
LORDS OF THE TREASURY
IN ORDINARY

TRIANCO
automatic boilers

379 Sth. Circular Road,
Rialto, Dublin, 8.
Phone 53029.

Stockists and Distributors:

MESSRS. THOS. HEITON & CO. LTD., 18 Westmoreland St., Dublin, 2.

MESSRS. BAXENDALE & CO. LTD., Capel Street, P.O. Box 56, Dublin.

TALL chimney stacks do not necessarily provide good natural draught under all weather conditions, and they are both costly to install and maintain. A discussion of mechanical versus natural induced draught, plus case histories of plants that replaced natural draught with mechanical draught inducers, show that it is possible to obtain considerable savings in both installation and boiler plant operating costs.

During the past decade, the wing mechanical draught inducer has been rapidly supplanting tall stacks in providing draught for boilers. This transition is the direct result of efforts by architects and engineers to keep down capital and fuel costs, and also to improve architectural appearance.

Advantages derived from mechanical induced draught have been well demonstrated over the years. There are numerous case histories which indicate that such equipment, complete with controls, may be purchased and installed at approximately 40 to 60 per cent. of the cost of a high stack. Furthermore, attractive fuel savings result from having the exact draught always available to satisfy varying load and weather conditions. Natural draught is most undepend-

able and subject to vagrancies of wind and weather. Buildings in areas subject to down draught, such as in valleys, under hills and where high wind velocities are experienced, such as coastal areas, will obtain considerable advantages and fuel economies by providing induced draught.

Natural Draught Is Not Dependable.

The foremost disadvantage of natural draught, provided by a chimney, is undependability. When a service man, for example, adjusts a burner, he obtains the maximum CO₂ commensurate with the draught available at the time. Later as this draught varies, so does the burner efficiency and the CO₂.

Chimney draught is poor when the stack is cool and good when it is hot. To allow for this variation, the burner

is usually adjusted for average to poor draught conditions. This assures adequate air to prevent smoking on cold start but results in considerable excess air when the stack is heated. The average CO₂ rating and overall combustion efficiency is consequently very poor. The draught at any time is subject to wide variation from changing weather conditions and/or down draughts caused by nearby hills or tall buildings. Thus, the serviceman must take these variables into account in making burner adjustments.

In contrast with the uncertainties of natural draught, a wing mechanical draught inducer provides positive and adequate draught on all occasions, and it eliminates or reduces the smoke resulting from insufficient draught.

Continued overleaf

COSTS CUT BY WING MECHANICAL DRAUGHT EQUIPMENT

AMERICAN-Standard Controls Division Brings **INDIVIDUAL CONTROL**

to every water-operated heating and cooling unit

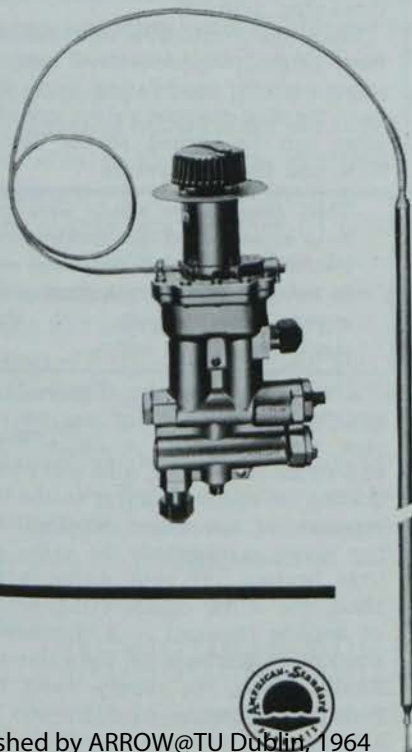

From the American-Standard Corporation of America come four Automatic Valves which bring individual control to every water-operated heating and cooling unit — the Duoflow, Selectaflow, Winterflow and Summerflow. Duoflow gives completely automatic year-round heating and cooling control for three pipe systems, Selectaflow is a dual purpose year-round heating or cooling control for two pipe systems, Summerflow is a single purpose cooling control, while Winterflow gives full control of heating. All American-Standard Control Valves are available in direct or remote actuator types to give automatic precision control with cost-saving results. For further details of these non-electric modulating valves, write to the sole U.K. Agents:

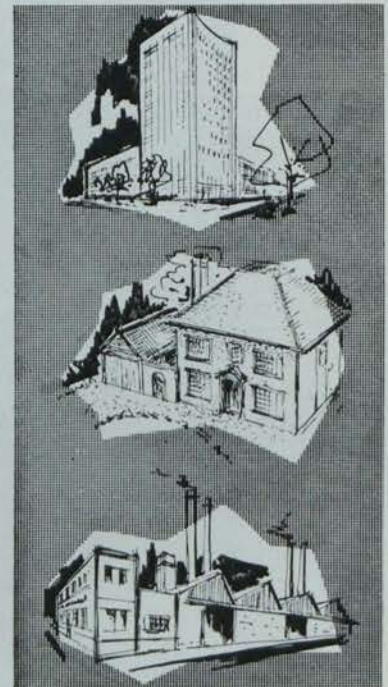

EUROPAIR



van den bosch Ltd.,

EUROPAIR HOUSE · ALEXANDRA ROAD · LONDON

S.W.19 · TELEPHONE: LAKESIDE 2281/4 · TELEX: 23931

The Irish Plumbing and Heating Engineer.

WE CONTINUE HERE OUR NEW SERIES OF ARTICLES OF WIDE SCOPE COVERING A VARIETY OF VITAL TOPICS

PART 2

ECONOMY IN AIR DISTRIBUTION OF FAN COIL AND INDUCTION UNITS THROUGH REGULATION

from previous page

Thus, burners may be adjusted to operate with high CO₂'s where induced draught is employed, resulting in reduced fuel consumption.

High Operating Efficiency.

Indicative of the high operating efficiency made possible by mechanical draught, the following was reported after a boiler installation was completed for an oil company.

The original heating plant was equipped with one boiler handling the entire load with draught provided by a stack approximately 50 ft. high. A test showed the best operating efficiency of this boiler to be 75%. This occurred on high fire. On low fire the efficiency reduced to a nominal percentage. Plant facilities were expanded and new specifications called for a second boiler identical to the first, with additional draught to be furnished by a wing draught inducer serving both boilers. Gases from the

wing draught inducer were to be discharged into the 50 ft. stack. When the wing draught inducer was placed in operation, it was found both burners could be operated at full rating and at 85% efficiency on low fire and 375 deg. F. stack temperature, and at 85% efficiency on high fire with stack temperature of 425 deg. Thus, in addition to saving the cost of an extra stack the wing draught inducer produced very attractive fuel economics from higher operating efficiencies.

To be continued

● Heitons have successfully concluded a sole agency agreement with the Shipley Fan Company Ltd., Yorkshire, for the Republic of Ireland and Northern Ireland. This firm specialises in speedy delivery, and are experts in design and manufacture of purpose made fans to suit stringent and diverse specifications.

(Text of lecture given by RICHARD BERNHARD, at the 2nd Europair Congress, Brussels. Edited by ALLAN CAVINDER, A.Inst.M.S.M.)

Four types of valves have been developed for two and three-pipe systems which control the water supply to individual fan-coil or air-water induction units for heating or cooling or dual-purpose year-round heating and cooling. The Winterflow valve is designed for the control of heating only. The Summerflow valve is designed for the control of cooling only. The Selectaflow dual-purpose valve is designed for heating or cooling in two-pipe systems—and the Duoflow valve is designed for complete year-round automatic heating and cooling for three-pipe systems.

Since the Winterflow and Summerflow single purpose valves have the same smooth, modulating control as have the dual-purpose valves, consideration can be limited to the Selectaflow and Duoflow valves.

THE illustrations which were to have accompanied this article were lost in transit. A duplicate set is being prepared and these will appear next month with the conclusion of the series.

The Selectaflow valve (Figure 3) was specifically designed for use on two-pipe systems having a single supply and single return line, and will control heating or cooling subject to the temperature of the water supplied. If hot water is supplied, the valve controls heating. If cold water is supplied, the valve controls the amount of cooling required. A thermostatic element in the base of the valve constantly senses the supply water temperature by means of a by-pass and automatically changes over from heating to cooling or vice-versa.



PREFERRED FOR PERFORMANCE IN SO MANY APPLICATIONS

BARE SHAFT PUMP
Rigid centre bracket, wide spaced shaft bearings. Duties to 900 g.p.m.

AUTO SELF-PRIMING PUMP.
1 1/2" for duties to 60 g.p.m. 3" for duties to 250 g.p.m.

SUMP PUMP
Float control switch incorporated. 1" 15 g.p.m. at 17 ft. hd., 1 1/2", 40 g.p.m. at 14 ft. hd.

TRUNK PUMP
Single and Multistage units to suit purpose. 1" Shaft and trunk pipe to suit depth of fluid.

WATER CIRCULATOR
Fullway - direct - in - pipeline. Duties to 110 g.p.m.

GLANDLESS ACCELERATOR
Silent, for central heating. 1" and 1 1/2".

UNISHAFT ELECTRIC
Compact and rigid 2 1/2" to 5 1/8" Duties to 900 g.p.m.

SAUNDERS VALVE COMPANY LIMITED

Safran Pump Division

DRAYTON STREET, WOLVERHAMPTON. Phone 25531.

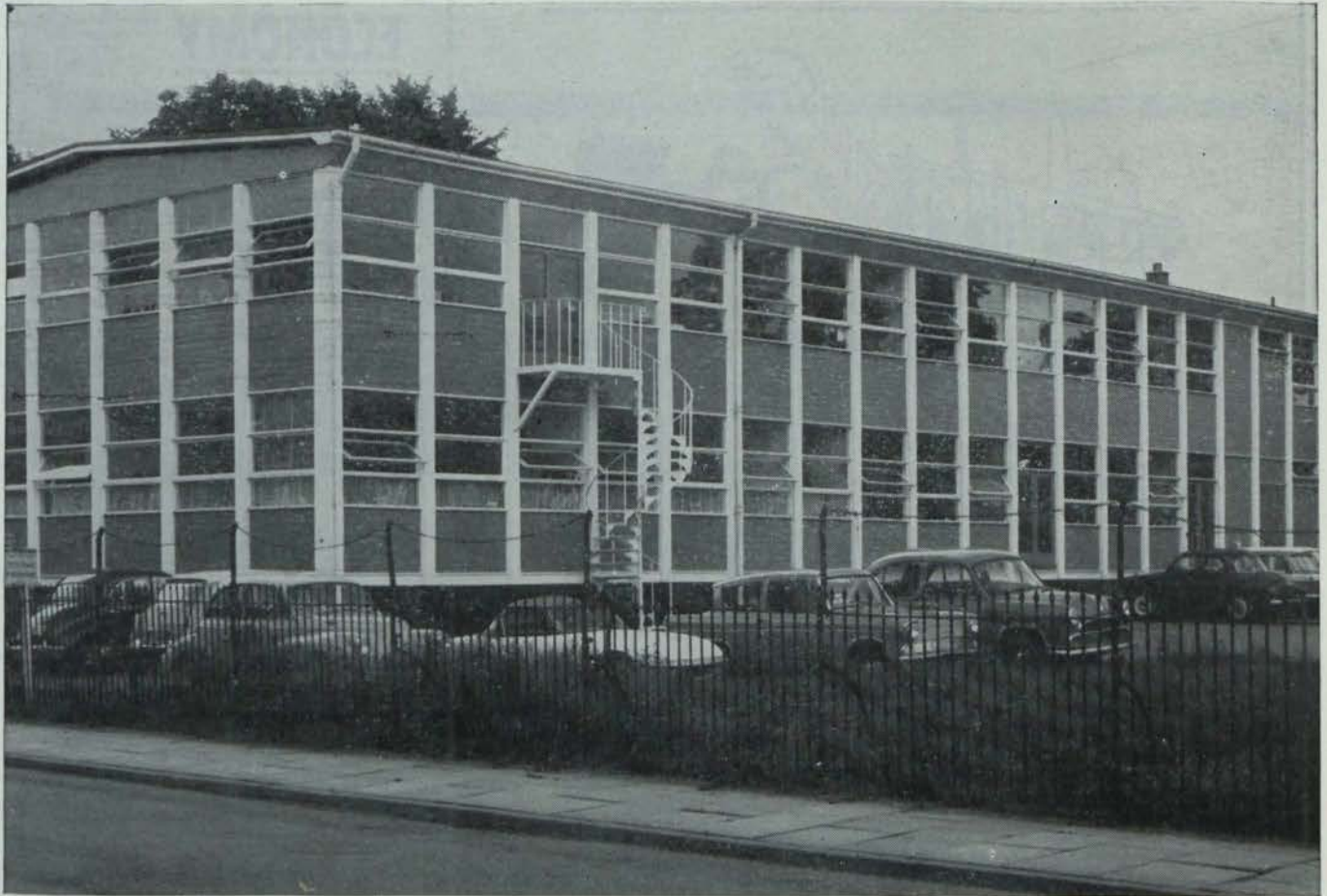

How Somerset County Council heated 20% more space for less money with a choice of fuels

A replacement boiler to heat 20% more space by either oil or automatic solid fuel firing at no extra cost and compact enough to get through a narrow doorway. This was the complex order the engineers at the Somerset County Architects Department handed to Allied Ironfounders in 1961. It was something even the huge Allied range of industrial boilers could not supply. So Allied built a new boiler. Installed in the County Architect's newly enlarged office, the 690,000 Btu/hr prototype not only heated the extra space but used 150 gallons less fuel than its predecessor during the bitter cold of the 1962/3 season. This boiler can be converted easily to automatically stoked solid fuel and arrived on site in three sections each less than 26" wide. From it Allied have developed the Allied GP range with ratings from 690,000 Btus to 1,200,000 Btus. Somerset C.C. have now installed these boilers in four other buildings and Wiltshire C.C. are following suit. Allied were called in because their experience, research facilities and production capacity are unique. If you need a new boiler or advice on any heating problem get in touch with Allied Ironfounders Ltd., Industrial Heating Division at Cadbury Road, Sunbury-on-Thames, Middlesex. Tel: Sunbury-on-Thames 5577.

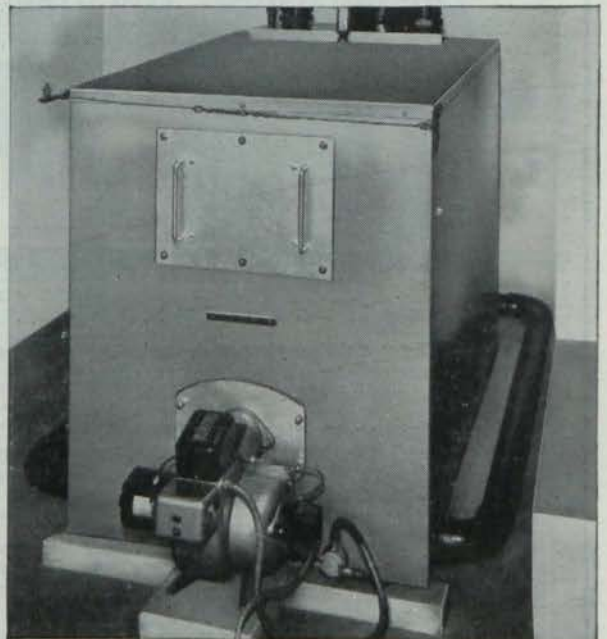

The original Allied GP boiler as installed at Somerset C.C. Architects Dept by Fisher & Sons Ltd Taunton

INDUSTRIAL BOILERS ARE MADE BY ALLIED IRONFOUNDERS 

Published by ARROW & CO. Dublin 1964 Industrial Heating Division Cadbury Road Sunbury-on-Thames Middlesex Tel: Sunbury 5577

BELFAST OFFICE: M A Graham Esq 20 Bedford Street Belfast 2 Telephone: 29087



**BUILDING EXTENSION?
HEATING PROBLEM?
CHIMNEY STACK?
DON'T BUILD ANOTHER STACK, A
C&N
WING DRAUGHT INDUCER
FITTED TO YOUR EXISTING STACK WILL
DO THE JOB BETTER AT FAR LESS COST
AND OVER COME ANY DOWN DRAUGHT**

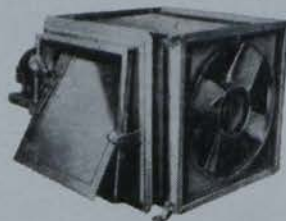

★ Produces draught only at time when required, at low operating cost and at a great saving on installation (savings can be over 25% of tall stack costs).

- ★ By providing proper draught for complete fuel consumption, regardless of weather conditions, fuel savings can be as much as 15%.
- ★ Sooner or later you will be faced with a draught problem and the Wing Draught Inducer will be the only way of dealing with it. We provide a full technical service dealing with all draught problems.

Manufactured by Curwen & Newbery Ltd. (one of the Applegate Group of Companies), Unicorn Works, London Road, Devizes, Wiltshire. Tel.: Devizes 973/4.

Details and leaflets from Main Agents:

W. FINUCANE & CO.

5 Upper Pembroke Street, Dublin, 2.

Tel.: Dublin 63634.

ECONOMY

from page thirty-eight.

This changeover characteristic of the Selectaflow valve permits its use to advantage in situations such as zoning where all units operating together will be required to supply either heating or cooling. A further advantage lies in the fact that the changeover from heating to cooling or vice versa needs only to be made at the source—that is, each valve and respective terminal unit will automatically adjust itself to its required function.

A distinct advantage of the Selectaflow valve is that it will not permit a wide swing of temperature at the time of changeover from heating to cooling as is common with many other types of control. In this valve, a small amount of water is continually passed over the thermostatic changeover element so that the valve will continue to function as a heating control, keeping temperature steady as required by the sensing element as long as there is hot water in the supply line. At changeover, any hot water present will eventually be dissipated through the by-pass until finally chilled water is present. Then the valve changes over and assumes control of the cooling function.

Figure 4 illustrates exactly how this valve operates on a heating cycle.

With hot water supplied to inlet A, a small amount of water is by-passed through B to warm the thermostatic element C. C expands because of the temperature increase, thereby pushing ball valve F against seat G. This is the automatic changeover feature of the Selectaflow valve. As a result, hot water is directed towards Ball J. A cool room needing heat causes the sensing element U with its capillary and power element V to relax the force on lever S, which in turn allows

Continued page forty-two

**Please remember
those subs**

By now I.P.H.E. readers will have had their annual Subscription renewal reminders. Please assist our circulation department by returning the Renewal Form as quickly as possible.

TROX *air distribution equipment*

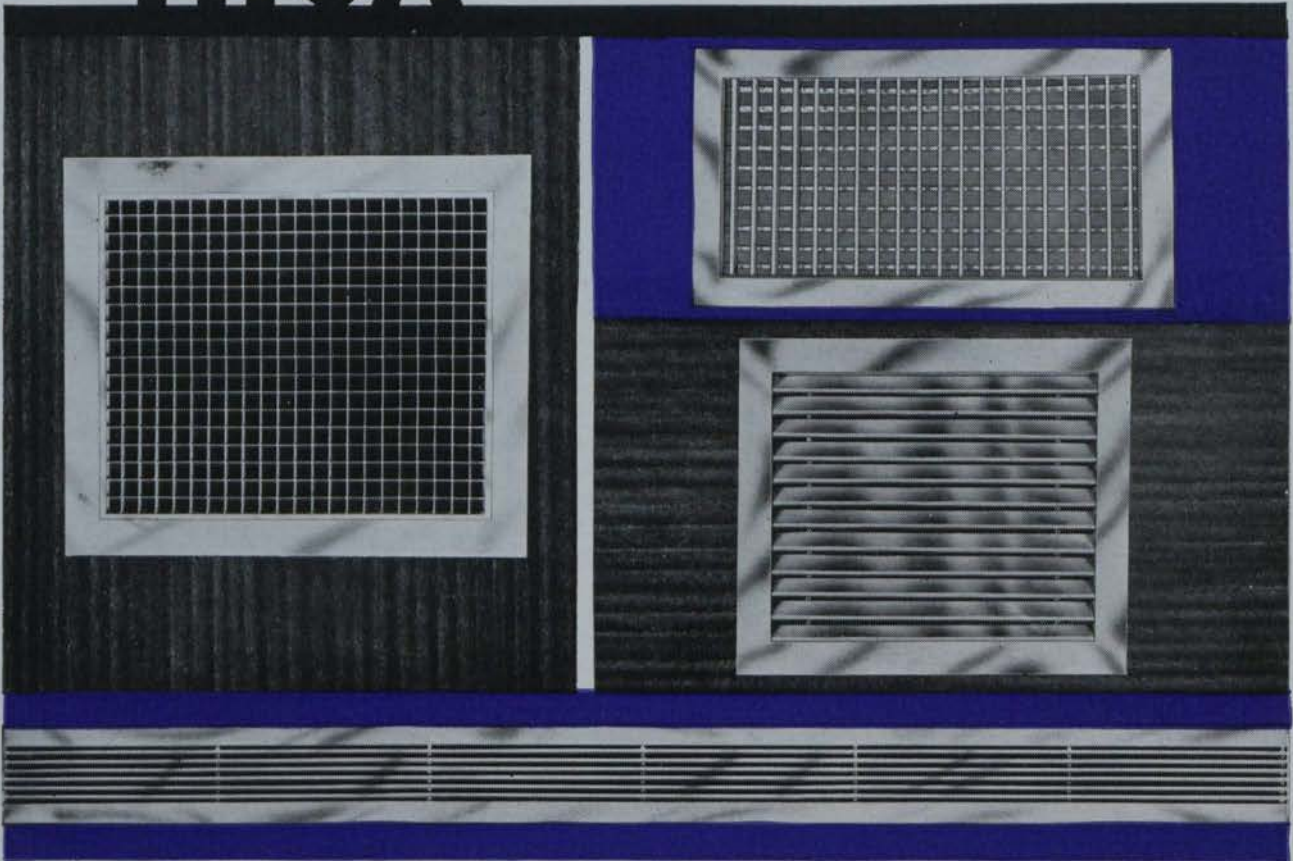

EXTRUDED ALUMINIUM GRILLES WITH SECRET FASTENING

Manufactured from solid extrusions, TROX high quality aluminium registers and grilles feature the unique TROX secret fastening device. Their fine finish and elegant design enhance the architectural merit of any modern building, while their performance versatility enables the most critical air distribution requirements to be fulfilled.

Every item in the comprehensive range of TROX equipment is a well designed, high quality product. TROX technical facilities are available to offer recommendations for all special requirements.

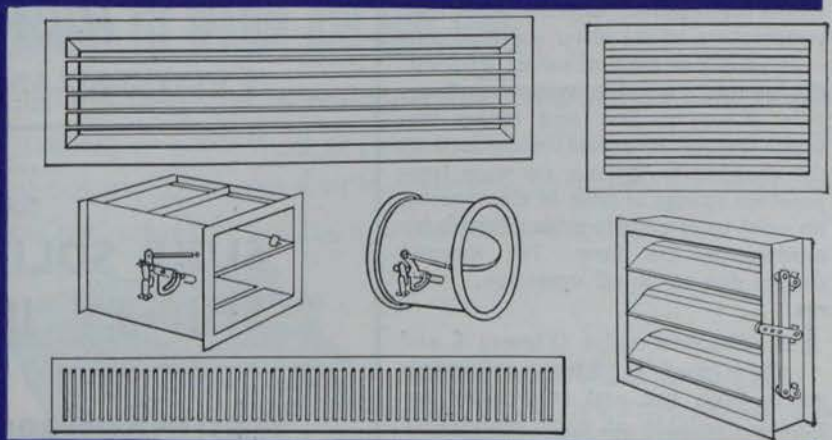

TROX

TROX BROTHERS LTD 238-240 Bethnal Green Road, London, E2

Agents for Ireland: W. Finucane & Co. 5 Upper Pembroke St., Dublin Tel: 63634

AUSTRIA · BELGIUM · FRANCE · HOLLAND · ITALY · SCANDINAVIA · SWITZERLAND · W. GERMANY

Forty-one

The Irish Plumbing and Heating Engineer.

the ball valve J to open. Note that under these conditions, the fulcrum point is at W. Hot water thus flows to the heating coil modulating in proportion to the demand for heat from the sensing element U.

When cooling is desired, as shown in **Figure 5**, cold water is supplied to inlet A and again a small amount of water is by-passed through B, thereby causing the thermostatic element C to contract and thus allowing a spring to move the ball valve F from seat G to seat H. Since a warm room, through the sensing element U, has already forced the ball valve J into the closed position, the fulcrum for lever S is now at point X and any further increasing force from the power element V pushes the ball valve N open against its spring P, allowing cold water to flow to the coil. As the room cools, the force from power element V decreases, allowing spring F gradually to close the ball valve N until equilibrium is established.

IT should be pointed out at this time that any flow taking place through the valve is in direct proportion to the sensing element temperature change, since the combination of the oil charge in the sensing and power element and the ball seat and needle design result in a linear flow characteristic for the valve. The thermostatic element, which is spring loaded in one direction, is made of Vernatherm, a patented material, and designed so that its neutral point is at 72 degrees Fahrenheit.

To sum up, the Selectaflow dual purpose valve is used for year-round heating or cooling in a two-pipe system. This type of valve offers the following benefits: Automatic summer-winter changeover depending on the temperature of the water supplied to it—no switch or manual valves involved; the simple two-pipe system includes only a supply line and return line which enhances zoned systems with the changeover feature; no wide temperature swings at time of changeover, no need to re-adjust; valve controls by modulating the flow. No thermal shocks due to on-off operation.

THE Duoflow valve (Figures 6 and 7) is used in three-pipe systems where both hot and cold water are always available at each fan-coil or air-water induction unit to produce either heating or cooling at any time of the year.

The sensing element is installed
Forty-two

AIR DISTRIBUTION

from page forty

within the cabinet of a fan-coil or inductor unit where the recirculated air enters each respective unit. The valve itself is located at either end of the terminal unit enclosure and is connected to the supply lines and coil inlet. The small by-pass line is connected to the drain line—on all valves; two locations of the actuator are available. The direct type actuator is shown on the illustrations. The remote type actuator can be located either 6 or 15 feet from the unit.

WHEN heat is required, hot water flows through the valve from the hot water supply line, and the valve modulates or throttles in accordance with the difference between the actual room temperature and the temperature desired. In similar fashion, chilled water flows through the valve and is governed by the amount of cooling required. If neither heating nor cooling is required, there is no flow at all. This feature, plus the fact that hot and cold water is never mixed, helps to reduce demands on the water heating and chilling equipment.

When heat is required on a Duoflow valve (Figure 8), the sensing element "U" located in the return air stream of each terminal unit, with its capillary and power element "V," relaxes its force on lever "S" and push rod "L." Hot water, under pressure, is allowed to flow through "K" to the

heating and cooling coil. As the room temperature increases, the force from power element "V" increases on lever "S" causing ball valve "J" to throttle the hot water flow. As this trend continues, ball valve "J" becomes seated at "K," at which point there is no flow of hot or cold water.

Under this condition, the neutral position is reached (Figure 9) and there is no mixing of hot or cold water. Note that the cold water spring load ball valve with its push rod continues to act as the fulcrum point for lever "S."

LET us assume that the room temperature rises beyond the actuator dial setting, thereby increasing the force from the power element "V" on lever "S" (Figure 10). Since the ball valve "J" is already seated and can go no further, the fulcrum point shifts from the cold water side to the hot water side at point "X" and the increased force is transmitted into ball "N," which overcomes spring force "P" and allows cold water to flow into the heating and cooling coil. Continued room cooling will eventually reverse this situation, returning the valve towards its neutral position. Note that the water flow, either hot or cold, is proportioned to the degree of heating or cooling required at any given instant. This is smooth modulating control providing much closer temperature regulation than is possible with on-off methods.

(To be continued)

THOS. HEITON & Co. Ltd.

Heating Division

18 WESTMORELAND STREET, DUBLIN. Tel. 72931

Sole Agents for:—

SUXÉ SOLID FUEL BURNERS
SHIPLEY INDUSTRIAL FANS

Sole Distributors for:—

White-Rodgers Heating & Air Conditioning Controls
Tel. 72931.



A NEW APPROACH TO WARM AIR DUCTING

Fibreglass Prefabricated Ducting is built and insulated in one operation. It's a rigid slab (available ready grooved for certain standard sizes) or preformed circular duct, with an attractive outer surface of aluminium foil. On-site operations are cut to one simple assembly, so installation costs are considerably reduced. Thermal insulation and sound attenuation properties are excellent.

Please write for all the details to:

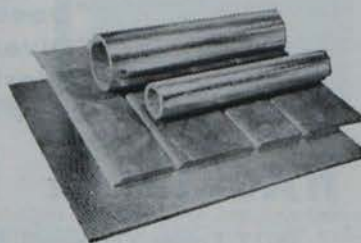

MONSELL MITCHELL & CO LTD

Sole Distributors of Fibreglass Heat Insulation Products in the Republic of Ireland.

JAMES RYAN (DUBLIN) & CO LTD

Sole Stockists of Fibreglass Air Filters in the Republic of Ireland.

21, MERRION SQUARE NORTH, DUBLIN

**Fibreglass
Limited**

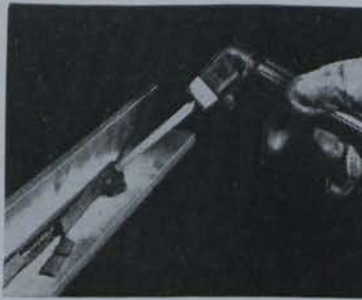

NEW CONTACT ELECTRODE INTRODUCED

A NEW contact electrode known as the Ferrocord, which is claimed by the manufacturers to deposit weld-metal almost as quickly as semi-automatic machines, and which does not require specially trained operators, has been introduced by Oerlikon Electrodes (Great Britain) Ltd. It has a flux coating exceptionally rich in iron powder, which gives it a recovery efficiency of 210%—i.e., in addition to the weld-metal derived from the central core-wire, a further 110% of metal comes from the iron powder. The deposit efficiency is 0.25 grammes per ampere per minute, and since the electrode will tolerate very high currents, metal can be deposited very rapidly indeed. One electrode 18 inches (46 cm.) long and 6 s.w.g. (5 mm.) in diameter can yield 24 inches (61 cm.) of weld-deposit in 95 seconds.

Welding with the Ferrocord requires a simple touch-welding technique: the end of the electrode is rested on the workpiece (see illustration) and metal melts off at a rate regulated by the welding current and the flux coating, the required weld-shape being formed without difficulty. A further advantage is that the slag formed is self-releasing—it lifts from the surface automatically and does not have to be chipped away. Because of this, the arcing factor of the electrode—the proportion of time the operator spends with weld-metal actually being deposited—is extremely high.

A new power-source for arc-welding—a medium-frequency alternator with a capacity of 255 amps, known as the EFS 250—has also been introduced by Oerlikon. For use in factories, shipyards and workshops, where three-phase mains current is available, it is normally driven by an A.C. motor; but it can also be



used on building sites, driven by a diesel or petrol engine or connected to an existing drive. The machine is highly mobile, being mounted on a two-wheeled trolley; in this form it weighs 225 lbs. (102 Kg.) com-

plete. The EFS 250 generates alternating current at a frequency of 425 c/sec. which, by increasing the electrical conductivity across the arc-gap, gives a more stable arc than 50-c/sec. current obtained from the mains through transformers.

RONALD TRIST & Co. Ltd., Slough—a subsidiary company of Bell's Asbestos and Engineering (Holdings) Limited, have announced an expansion of production capacity for their Controls Division by the establishment of a new factory at Cumbernauld near Glasgow, where production will commence early in 1965.

A UNIQUE BOILER-TUBE CLEANING UNIT!

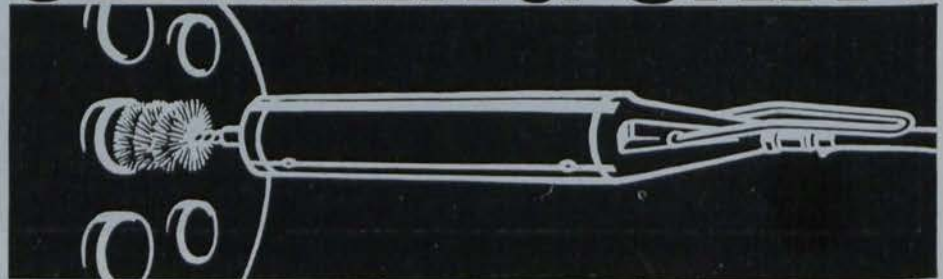

The Ferret is a completely unique type of boiler-tube cleaning unit. Attach it to a standard tube brush and it will creep along the tube—without revolving—and without any need for manual pushing and pulling! When it reaches the tube end, the double thrust action then reverses and the Ferret returns—ready for the next tube!

- THE FERRET**
- *Cuts labour time—no manual pushing and pulling
 - *Does away with extension rods.
 - *Gives cleaner tubes.
 - *Works quickly.

For Publication No. 208, or a demonstration in your own plant, contact:

HALPIN & HAYWARD LTD.,

16/17 Lower O'Connell Street, Dublin, Eire. Dublin 48638/9.

WATER STORAGE

the
ASBESTOS
way



No water storage problems
if you instal Asbestos
Cement tanks. Strong,
light and economically
priced Asbestos Cement
tanks cannot rust
or corrode and
require no maintenance.

For details, write today!

ASBESTOS CEMENT LIMITED

19 Lr. Pembroke St., Dublin 2.

Asbestos

Grosvenor

Published by Irish Trade and Technical Publications Ltd., Callaghan Chambers, 13-15 Dame St., Dublin, 2.
Printed by The Greyhound and Sporting Press Ltd., Davis Road, Clonmel.



Meet the BIG Supermatic family...

all 18 of them

It's most useful and highly profitable to deal with such a versatile and practical family of 'Wall Flame' Oil-fired Boilers as Supermatic—the biggest, fastest-growing and most successful yet produced.

For one thing, you're able to satisfy *ally* your customers, whatever their individual requirements may be—for the wide Supermatic range includes as many as 13 standard models *plus* 5 de luxe versions. Since their outputs vary from 44,000 to 300,000 BTUs, there's no problem in obtaining the *right* Supermatic boiler for the smallest or biggest heating jobs. Installers and householders don't need to make do with inferior, unsuitable or uneconomical substitutes—because you can always get them *exactly* what they want. In

addition, you can increase your profits by selling them sleek, highly efficient Supermatic Skirting Radiators—specially designed to operate best with Supermatic 'Wall-Flame' Oil-fired Boilers.

What's more, you can bank on *immediate deliveries*—thanks to our no-delay, *same-day dispatches* from huge stocks always maintained at our Eastbourne works.

It's more than likely that you will soon be ordering more Supermatic Boilers and Skirting Radiators than ever. Why? Because this year, we have more than *doubled* our publicity expenditure—to stimulate more public interest, attract many more customers to your door and boost your profits substantially.

It PAYS to ORDER Supermatic—INSTALL Supermatic—RECOMMEND Supermatic—SELL Supermatic

Fill in and post this coupon TODAY!

To Dept.
PERRY HEATING APPLIANCES LTD
Hampden Park, Eastbourne, Sussex

Please send me full particulars of your Supermatic Oil-fired Boilers and Supermatic Skirting Radiators and details of your trade terms.

Name

Address

.....

.....
(BLOCK LETTERS PLEASE)