

2007-01-01

Small Patch/Slot Antenna with 53% Input Impedance Bandwidth

Xiulong Bao

Technological University Dublin, xiulong.bao@tudublin.ie

Max Ammann

Technological University Dublin, max.ammann@tudublin.ie

Follow this and additional works at: <https://arrow.tudublin.ie/engscheceart>



Part of the [Electrical and Computer Engineering Commons](#)

Recommended Citation

Bao, X. & Amman, M. (2007) Small Patch/Slot Antenna with 53% Input Impedance Bandwidth. >i>Electronics Letters, Feb. 1 2007, vol. 43. no. 3, pp.146-148. doi:10.1049/el:20073279 .

This Article is brought to you for free and open access by the School of Electrical and Electronic Engineering at ARROW@TU Dublin. It has been accepted for inclusion in Articles by an authorized administrator of ARROW@TU Dublin. For more information, please contact arrow.admin@tudublin.ie, aisling.coyne@tudublin.ie.



This work is licensed under a [Creative Commons Attribution-Noncommercial-Share Alike 4.0 License](#)

Small patch/slot antenna with 53% input impedance bandwidth

X.L. Bao and M.J. Ammann

A small microstrip patch/slot antenna, which achieves a very large bandwidth on a relatively thin substrate (about $0.01\lambda_0$), is presented. The performance is achieved by employing a combination of annular-loading on the patch radiator and the use of a crossed-slot for miniaturisation. An additional ring-slot in the ground plane is used to produce the wideband characteristics of the antenna. Simulated and measured results indicate that a 53% fractional impedance bandwidth is achieved with respect to the centre frequency of 1.409 GHz and the size of the antenna is reduced by 50% compared to the conventional circular patch antenna with respect to a given frequency.

Introduction: Microstrip patch antennas have found extensive application in wireless communication systems owing to their advantages such as low-profile, conformability, low-cost fabrication and ease of integration with feed networks [1]. However, one of the main limitations of microstrip patch antennas fabricated on a relatively thin substrate is the narrow bandwidth, typically about 5% bandwidth with respect to the centre frequency. To increase the bandwidth of the microstrip patch antenna, many different techniques have been used, such as using a thicker substrate with lower relative permittivity, or using a T-shape feed probe. Other techniques involve employing multilayer structures with parasitic patches of various geometries such as E, V and H shapes, which excite multiple resonant modes [2–5]. However, these antennas are generally fabricated on thicker substrates. Miniaturisation is also extremely important for modern wireless communications. Techniques such as using shorting pins/walls in combination with high dielectric constant substrates have been reported [6, 7]. But these miniaturisation techniques can reduce the bandwidth of the patch antenna. The use of loading slots in the ground plane has also been reported to reduce the antenna size and increase the gain [8, 9]. There has been little research considering both broadbanding and miniaturisation of thin substrate patch antennas simultaneously. In the open literature, the technique of slot loading the groundplane has not been applied to the extension of bandwidth for a patch antenna.

In this Letter, a probe-fed single-layer annular-ring patch/slot antenna on a thin substrate (about $0.01\lambda_0$) with slotted groundplane is proposed and a 53% fractional impedance bandwidth is achieved. An antenna size reduction of about 50% compared to a conventional circular patch antenna for a given frequency is also achieved.

Design of wideband annular-ring patch/slot antenna: A small circular patch antenna concentrically embedded in an annular-ring, with a cross-slotted ground plane has been reported to reduce the antenna size for circular polarisation [10]. In this Letter, we propose a novel structure to realise both broadband characteristics and miniaturisation. The proposed antenna configuration is shown in Fig. 1. It is printed on an FR4 substrate with a relative permittivity of 4.2, a thickness of 1.52 mm, and a loss tangent of 0.018. A $50\ \Omega$ coaxial probe is used to feed the circular patch. The very wide bandwidth is achieved because of the various resonant modes that are generated by the circular patch, the concentric annular-ring patch, the annular-slot and the slotted groundplane. The frequencies for the multiple resonant modes are merged by adjusting the parameters of the antenna. The optimised dimensions of the proposed antenna are as follows: $D1 = 54\ \text{mm}$, $D2 = 39.2\ \text{mm}$, $D3 = 25\ \text{mm}$, $SD1 = 54\ \text{mm}$, $SD2 = 48\ \text{mm}$, $SD3 = 9\ \text{mm}$, $L1 = L2 = 44.0\ \text{mm}$, $W = 2.0\ \text{mm}$. The feed point of the coaxial probe is located at (4 mm, 4 mm). The ground plane size is $80 \times 80\ \text{mm}$.

Simulation and measurement results: Fig. 2 shows the simulated and measured results of return loss for the proposed antenna. It is noted that simulated results are in good agreement with the measured results. The measured input impedance bandwidth for which the return loss is greater than 10 dB is 745 MHz from 0.987 to 1.832 GHz, which is about 53% fractional bandwidth with respect to the centre frequency of 1.409 GHz. This is a considerable bandwidth for a single-layer thin-substrate probe-fed antenna. The antenna size is small, considering that the groundplane size is $0.26\lambda_0$ square and the annular ring/slot ring diameter is $0.09\lambda_0$. The normalised measured radiation patterns at 1.19, 1.38 and 1.63 GHz are shown in

Figs. 3a and b for the xoz and yoz planes, respectively. They illustrate a fairly omnidirectional pattern with poor front-to-back ratio, which is caused by a combination of the small groundplane and the slots in the groundplane. However, they also show a relatively stable pattern with change of frequency. The gains at 1.19, 1.38 and 1.63 GHz are 2.2, 3.0 and 3.8 dBi, respectively.

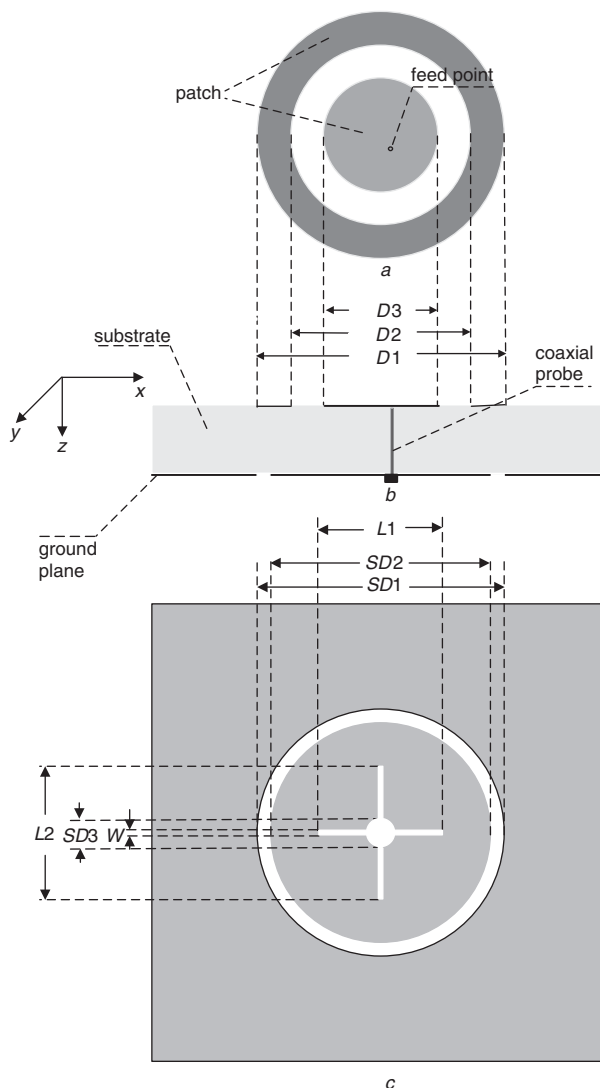

Fig. 1 Geometry of proposed microstrip patch antenna

- a Patch
- b Substrate
- c Groundplane slots

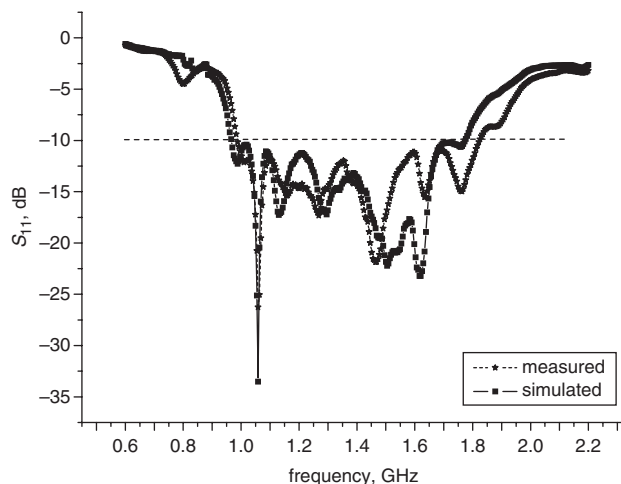

Fig. 2 Simulated and measured return loss for proposed wideband antenna

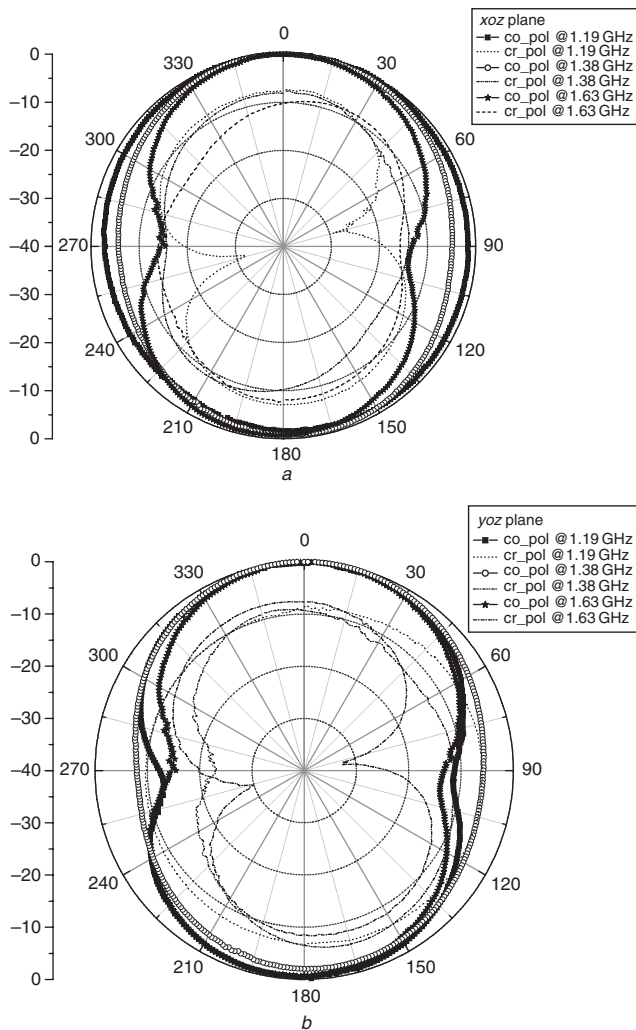

Fig. 3 Measured radiation patterns

a Radiation patterns for *xoz* plane at 1.19, 1.38 and 1.63 GHz
b Radiation patterns for *yoz* plane at 1.19, 1.38 and 1.63 GHz

Conclusions: A small wideband annular-ring loaded patch/slot antenna with slot loaded groundplane has been studied numerically

and experimentally. The results indicate that the proposed antenna can achieve both miniaturisation and very wideband characteristics simultaneously on a thin substrate. The low-profile antenna can provide a 53% input impedance bandwidth with reasonable pattern stability.

© The Institution of Engineering and Technology 2007

23 October 2006

Electronics Letters online no: 20073279

doi: 10.1049/el:20073279

X.L. Bao and M.J. Ammann (*Centre for Telecommunications Value-Chain Research, School of Electronic & Communications Engineering, Dublin Institute of Technology, Kevin Street, Dublin 8, Ireland*)

E-mail: max.ammann@dit.ie

References

- Pozar, D.M., and Schaubert, D.H.: 'Microstrip antennas: the analysis and design of microstrip antennas and arrays' (IEEE Press, Piscataway, NJ, USA, 1995)
- Weigand, S., Huff, G.H., Pan, K.H., and Bernhard, J.T.: 'Analysis and design of broad-band single-layer rectangular U-slot microstrip patch antennas', *IEEE Trans. Antennas Propag.*, 2003, **51**, (3), pp. 457–468
- Yang, F., Zhang, X., Ye, X., and Rahmat-Samii, Y.: 'Wide-band E-shaped patch antennas for wireless communications', *IEEE Trans. Antennas Propag.*, 2001, **49**, pp. 1094–1100
- Rafi, Gh., and Shafai, L.: 'Broadband microstrip patch antenna with V-slot', *IEE Proc., Microw. Antennas Propag.*, 2004, **151**, (5), pp. 435–440
- Lu, J.-H.: 'Bandwidth enhancement design of single-layer slotted circular microstrip antennas', *IEEE Trans. Antennas Propag.*, 2003, **51**, (5), pp. 1126–1129
- Mok, W.C., Chair, R., Luk, K.M., and Lee, K.F.: 'Wideband quarter-wave patch antenna with shorting pin', *IEE Proc., Microw. Antennas Propag.*, 2003, **150**, (1), pp. 56–60
- Li, Y., Chair, R., Luk, K.M., and Lee, K.F.: 'Broadband triangular patch antenna with a folded shorting wall', *IEEE Antennas Wirel. Propag. Lett.*, 2004, **3**, pp. 189–192
- Chen, H.D.: 'Compact circularly polarised microstrip antenna with slotted ground plane', *Electron. Lett.*, 2002, **38**, (13), pp. 616–617
- Kuo, J.S., and Hsieh, G.B.: 'Gain enhancement of a circularly polarized equilateral-triangular microstrip antenna with a slotted ground plane', *IEEE Trans. Antennas Propag.*, 2003, **51**, (7), pp. 1652–1656
- Bao, X.L., and Ammann, M.J.: 'Compact annular-ring embedded circular patch antenna with cross-slot ground plane for circular polarisation', *Electron. Lett.*, 2006, **42**, (4), pp. 192–193