

3-1-1964

### The Irish Plumbing and Heating Engineer, March 1964 (complete issue)

Follow this and additional works at: <https://arrow.tudublin.ie/bsn>

 Part of the [Civil Engineering Commons](#), [Construction Engineering Commons](#), and the [Construction Engineering and Management Commons](#)

---

#### Recommended Citation

(1964) "The Irish Plumbing and Heating Engineer, March 1964 (complete issue)," *Building Services Engineering*: Vol. 3: Iss. 12, Article 1.

doi:10.21427/D7RX3G

Available at: <https://arrow.tudublin.ie/bsn/vol3/iss12/1>

This Article is brought to you for free and open access by the Journals at ARROW@TU Dublin. It has been accepted for inclusion in Building Services Engineering by an authorized editor of ARROW@TU Dublin. For more information, please contact [arrow.admin@tudublin.ie](mailto:arrow.admin@tudublin.ie), [aisling.coyne@tudublin.ie](mailto:aisling.coyne@tudublin.ie), [vera.kilshaw@tudublin.ie](mailto:vera.kilshaw@tudublin.ie).

# ENGINEER

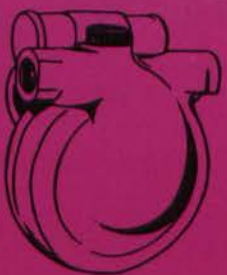

BOSS RAD 66. and 100.

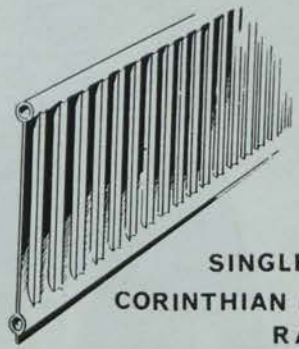

SINGLE & DOUBLE  
CORINTHIAN COPPERAD  
RADIATORS

## THE BRITISH STEAM SPECIALTIES LTD.

supply heating and pipeline  
equipment for factories, stores,  
offices and public buildings  
B.S.S. Ltd. can supply complete  
equipment for heating installations  
and all ancillary equipment for steam,  
water, gas, oil and compressed air  
pipelines.  
B.S.S. Ltd. have large stocks available  
from branches at Dublin and Belfast.

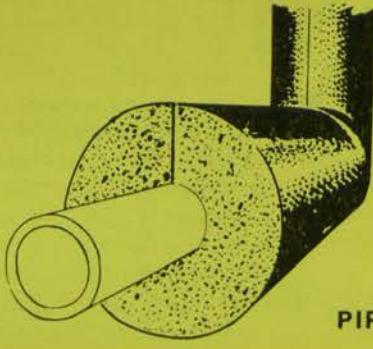

FOAMFLEX  
1/4" - 4" PIPES  
PREFORMED  
PIPE INSULATION



**DUBLIN**  
33 Leeson Park  
Dublin, 6  
Dublin 66961-2-3-4  
Telex 317



BOSS WHITE

**BOSS TANK**  
Contents GAUGES



**CLAUDO**  
VALVES

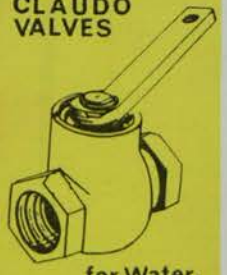

for Water,  
Oil and Air.

**BELFAST**  
Distillery Street  
Belfast, 12  
Belfast 28031 (3 lines)  
Telex 74561

**GLENFIELD & KENNEDY S.& S.**  
DIAPHRAM  
VALVES  
for use on  
Water, Oil,  
Air and Gas

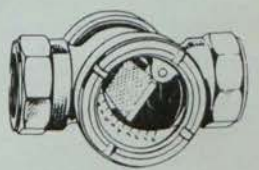

**RHODES**  
Sight Flow  
INDICATORS

## “Still living in the thirties, Dad?”



Look, the way to make money in plumbing is to cut your costs of materials. Right? And cut your labour-time. Right?

**RIGHT!** It's easy. Turn to the Wavin system and forget all other forms of piping. Why?

**YOU SAVE ON MATERIAL—** You can buy Wavin hard PVC Pipe for as little as 2d $\frac{1}{2}$  a foot.

**YOU SAVE ON TIME—** Wavin is easy to transport and handle. It can be joined—permanently—in seconds.

**YOU HAVE A COMPLETE RANGE—** Wavin is a complete system. Your stockist carries everything a plumber needs for any job.

**YOU SAVE YOURSELF TROUBLE—** All the modern Plumber needs is a hacksaw and a tin of cement. In short, for a water or chemical plumbing job, Wavin is the cleanest, quickest, neatest, most convenient money-earner. Quote on Wavin!



# wavin

*worth looking into ...*

WAVIN PIPES LIMITED (Head Office and Works) BALBRIGGAN. Telephone 212263.  
Also at London, Liverpool, Lisburn.

# A Newcomer To The Irish Market



**RENNERT & CO., Gmbh., Dusseldorf**



Manufacturers of Sanitary Fittings since 1919

● MAKERS OF QUALITY FITTINGS FOR BATHS, BASINS, SINKS, ETC.

● **temperfix**  
THERMOSTATIC VALVES

Agent for Ireland:

**G. F. Morley Ltd.**

45 Quinn's Lane, Fitzwilliam Sq.,  
Dublin, 2. Telephone: 66949.

## Taps & Mixers

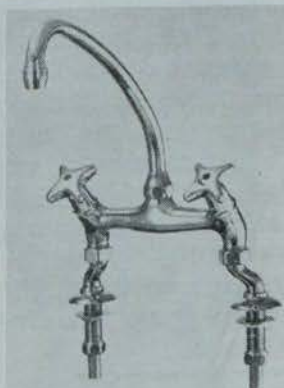

ABOVE — Sink mixer with nozzle. Other nozzle shapes available without extra charge.



ABOVE — Pillar tap.  
BELOW — Highneck sink pillar cock with raised nose giving 4" clearance.



ABOVE—Shampoo shower mixer with tulip handles, connections, flexible tube handshower and hook.

A NEW  
PRODUCT

## "THE DUBOIS PLASTIC TRAP" (Regd.)

A NEW  
PRODUCT

Provn. Pat. No. 38070/60.

1 1/4" and 1 1/2" diam. x 1 1/2" seal "S" and "P" BLACK HIGH DENSITY PLASTIC TRAPS

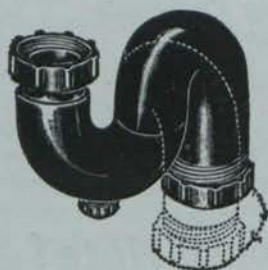

Orthodox Shape!  
Smooth Bore Tubular construction.  
Outlets can be turned through 220°.  
A two-piece trap at a one-piece price.  
Outlet on 'S' trap turned to inlet forms a through-bore bottle trap.  
Frost and damage resisting.  
Light weight = lower transportation costs.



Manufactured by:—

**THE DU BOIS COMPANY LIMITED**  
15 Britannia Street, London, W.C.1

Telephone No.: TERminus 6624-5.

Telegraphic Address: "Bleitrap, London."

One

# 1964 DIRECTORY

## of MANUFACTURERS, AGENTS, REPRESENTATIVES and DISTRIBUTORS

Please Check  
This List  
Of Categories

— LIST NO. 3 —

★ The June 1964 Register of Manufacturers, Agents, Representatives and Distributors of Domestic and Industrial Plumbing, Heating, Air Conditioning, Ventilation and Insulation equipment and materials available in the Republic of Ireland and Northern Ireland is now being prepared. The Directory this year will again be enlarged to accommodate the many additional entries under the industrial heading.

If you come under the heading of any of the categories listed here and have not supplied information already, or wish to make amendments or alterations to last year's entries, we would ask you to do so without delay. Names and addresses of Agents and/or Representatives should be included with all entries. If you require an Agent, please indicate accordingly.

### Have you checked these already published lists?

- Air Cleaners, Electronic
- Air Conditioning Equipment
- Air Vents
- Air Washers
- Autoclaves
- Automatic Clock Controllers
- Blowers and Exhausters
- Boiler Controls
- Boiler Fittings
- Boilers (Domestic and Industrial)
- Burners, Gas/Oil/Solid Fuel
- Baths, Basins, Bidets and Sinks
- Calorifiers
- Chimneys, Tops and Cowl
- Cisterns, Tanks and Cylinders
- Cocks
- Coils
- Combustion Equipment
- Compressors, Air and Gas
- Control Equipment & Controllers
- Control Panels
- Convectors
- Coolers
- Cyclones
- Drainage and Sanitation-Traps and Wastes
- Damper Regulators & Quadrants
- Dehumidifiers
- Draught Stabilisers
- Drying Apparatus

- Dust Collection Plant
- Economisers, Fuel
- Ejectors, Steam
- Electric Heating Elements
- Electric Heating Equipment
- Electric Heating Tape
- Expansion Joints
- Extractors and Ventilation Fans
- Fan Speed Regulators
- Fixing Tools & Bolt Driving Guns
- Filters, Air
- Filters, Liquid, Oil, Water, etc.
- Flame Failure and Protection Devices
- Floodlighting Equipment (Portable)
- Floor Heating Installations
- Flue-Gas Corrosion Protection
- Fuel Additives
- Fuel, Ash and Clinker Conveying Plant
- Fume Removal Equipment
- Gauges, Air, Pressure, Vacuum, etc.
- Gauges, Liquid
- Gauges, Liquid Level
- Generators (Steam)
- Grilles, Louvres, etc.
- Grit Arresters
- Headers
- Heaters, Air
- Heaters, Water
- Heating Equipment Supplies
- Heat Exchangers
- Heating, Storage
- Hospital Equipment
- Humidifiers
- Humidity Controllers, Indicators, Recorders, etc.

- Incinerators
- Injectors, Nozzles, etc.
- Instruments, Meters, Indicators, Gauges, etc.
- Insulation
- Jointing Compounds
- Kitchen Units
- Liquid Handling Equipment
- Lubricators
- Pipe Bending Equipment
- Pipes, Tubes and Pipe Fittings
- Pipes and Tubes, Plastic
- Pipes and Tubes, Soil and Drain
- Pressure Booster Sets
- Pressure Controllers
- Pressurising Equipment
- Pressure Switches
- Pressure Vessels
- Pumps and Circulators
- Pyrometers
- Radiators
- Recording Equipment and Recorders
- Refractories
- Refractory Linings
- Refrigeration Plant
- Regulators
- Roofing Copper and Materials
- Roof Drains, Waterheads, Gutters and Outlets
- Roof Units (Ventilation)
- Rustproofing
- Sealing Compounds
- Sewage Disposal
- Sight Glasses
- Silencers
- Steam Traps
- Stokers

**Please Note!**

**CLOSING DATE**  
**Saturday,**  
**2nd May, 1964**



## Roman style central heating is in news again

**I**T'S those Romans again! In our January issue we told how Roman techniques had been used to heat a house in Falkirk, Scotland, and now from Reculver, near the Thames estuary, comes more Roman-style central heating news.

The furnace chamber of a third century Roman fort has been uncovered by excavators to reveal a number of unusual features.

The chamber is large, measuring overall some fifteen feet square, with internal dimensions of about ten by eleven feet, and is sunk below present ground level by some three to four feet. The hot air from the furnace was conducted by means of flues into the walls, and then by linking channels and a tunnel to the structure requiring the heat. Other furnace-chambers discovered elsewhere are normally much smaller with a single large flue at one end connecting immediately to the space under the floor of the rooms to be heated.

From this underfloor area the warmed air normally passed to vertical flues built inside the walls and thence to roof-level and the outside air. This system produced the required induced draught.

But a cross-channel heating, cooling and air conditioning firm—Air Coil Products Ltd. of Kent—are keeping

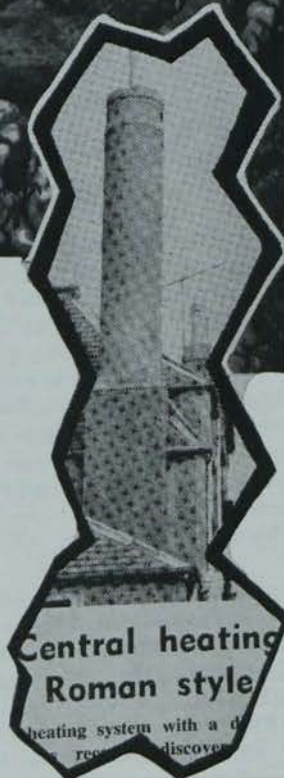

Central heating Roman style

- The Reculver find and flashback to our January report.

a few more revelations up their sleeve. They have based a £100 "Guess How" competition on these as yet untold aspects of the chamber, so it looks as if we have not yet heard the last of the Romans and their central heating methods.



This issue contains a comprehensive preview of the forthcoming HEVAC Exhibition at Olympia. Next month our own representative will be at Olympia and his reports will appear in forthcoming issues.

## IRISH PLUMBING & HEATING

# ENGINEER

Vol. 3. No. 12. MARCH

THE IRISH PLUMBING AND HEATING ENGINEER is the only publication produced in Ireland catering exclusively for the heating, plumbing and ventilation industries with a guaranteed circulation covering the Republic of Ireland and Northern Ireland every month.

Readers will be glad to hear that while A. L. Townsend's regular series ended last month with the conclusion of part one of his comprehensive study on plumbing, we will begin serialisation of stage two of this work later in the year.

W. J. R. Couchman resumes his Seven Deadly Sins series with another sparkling article for domestic heating installers.

Research metallurgist D. P. Smith, Ph.D., A.R.S.M., D.I.C., contributes an important article on solders and soldering for the plumbing trade.

This month's special Review deals with roofing materials. A product Review covers many of the new introductions.

The HEVAC Exhibition opens in Olympia next month and this issue takes a Preview look at the new products and equipment being introduced there.

●  
Editorial and advertising offices:

Callaghan Chambers, 13/15 Dame Street, Dublin 2. Tel. 56465-6.

London: J. T. Robson & Son Ltd., 30 Fleet Street, London, E.C.4. Tel.: Fleet Street 4438.

Belfast: Allen McDowell, 43 Horn Drive, Belfast 11. Phone 614606.

# trade Topics

**RHEEM GLOW-WORM Limited**—part of the Glow-Worm Boilers organisation — have introduced a range of ducted warm air central heating units. The range covers three sizes with outputs of 35,000, 53,000 and 70,000 B.t.u./hr., and each size is available as an up-flow or down-flow model.

The heat exchanger is of cast iron sectional construction, the sections covered with both internal and external thermal pins for maximum heating efficiency. The all enveloping steel cabinet is of heavy steel construction, lined with aluminium foil faced fibreglass insulation and finished in two-tone stove enamel.

Controls consist of a Honeywell composite control gas valve embodying a flame failure device, main gas and pilot cock, gas pressure governor and electric operator on main burner supply. The full range of safety and limit controls and plug-in provision for a time clock and room thermostat are provided. Rheem Glow-Worm warm air units include extra large easily replaceable air filters and can be supplied for connection to existing flues. Summer cool air circulation can be obtained by switch operation.

\* \* \*

A NEW leaflet on New-Wall expanded polystyrene wallpaper backing is available from New-

## NEW LEAFLET FROM NEWALLS INSULATION

alls Insulation Company Ltd. of Washington, Co. Durham—a Turner & Newall company. An interesting feature of the leaflet is a sample piece of New-Wall which provides a "demonstration" of the material's effectiveness in preserving warmth in rooms and keeping out damp and condensation.

# in BRIEF

The recent appointment of the Irish Development Supply Company of Dublin as agents for Gummars Limited marks a further stage in the development of the Rotherham company's interest in markets here.

Gummars Limited, of course, are already well-known through their Belfast office, which has been in operation for many years. The Belfast office is controlled by their well-known representative, Mr. M. A. Graham.

\* \* \*

MR. JAMES HANNA has been appointed managing director of Thos. Heiton & Company. He was formerly secretary and a member of the Board.

\* \* \*

With a view to improving its services to the gas industry, and also to enable it to be in a position to operate with full efficiency in changing marketing conditions, Radiation Ltd. has reorganised the sales forces of their companies marketing gas appliances to enable each to concentrate on the promotion of an individual appliance load, e.g., cookers, fires, water heaters and central heating.

\* \* \*

A NEW "wrap round" radiator output boiler, designed to give a much higher output than the conventional back boiler, has been produced by Baxi, Bamber Bridge, Preston, Lancs., manufacturers of the Baxie underfloor draught fire.

Known as the R.O.B. 2, the boiler has waterways extending to the front of the side checks as well as the back of the fire, ensuring maximum hot water output for radiator heating and domestic purposes.

\* \* \*

Mr. T. C. Kavanagh, Sales Representative, Curran Limited of Clonmel, checking a display of the new recently - introduced Curran all-steel bath.

THE British Consumers Association has tested all the electric radiant-convector heaters on the market

## C.A. TESTS ELECTRIC HEATERS

between 2,500 and 3,000 watts and reports in the current issue of their publication, "Which?": how comfortable they make a room; how safe they are; and how easy they are to use.

CA had built a special room to test just how comfortable heaters will be in use. The room is roughly equivalent to an ordinary living room but CA could regulate the temperature of the air outside it and record the temperature at 48 points inside it. At each of these points both the temperature of the air and the amount of radiant heat are measured. From all this it is possible not only to say how hot it is at any particular point but also to assess how comfortable a heater under test makes a room.

All but two passed the safety tests in the British Standard; but on one heater the electrical insulation failed on two samples; on this and one other a broken element which might be hot could fall onto the floor.

The best heater in the performance tests was expensive (Belling Infra-Zephor). With it three others that also did well were recommended as joint best buys: Belling Radiant-Zephor, Belling Vogue, and Morphy Richards Medway.

\* \* \*

THE NEW Powell Duffryn A.40 solid-fuel boiler operates with natural draught and because

## NEW P.D. SOLID FUEL BOILER

there is no fan it is completely quiet; it feeds itself by gravity so needs charging only once a day in winter when the central heating is on and only once every three days in summer when domestic hot water only is required.

The boiler forms its own refuse into a neat cool "brick" which can easily be removed; there is no raking and, therefore, no dust.

A thermostat, operating primary air damper, keeps water temperature just as required, and should the power fail then the damper can be operated by



**T**HE automation of home heating is the outstanding development featured at HEVAC, the International Heating, Ventilating and Air Conditioning exhibition at Olympia, London, next month.

Control systems have been simplified to bring them to the same degree of solid reliability as the old-fashioned man-operated "push the damper in" technique. Some of the systems use electronic black-boxes, made up of solid circuit elements that can be expected to work for years without attention.



Another big HEVAC Exhibition opens at Olympia next month. The I.P.H.E. will have its own correspondent at HEVAC and his reports will appear in forthcoming issues. These pages carry a preview of the exhibition.

Oil-fired installations use electronic eyes to watch the flame and control fuel supplies. Several of the controls on show are the direct development of elaborate industrial systems which have been proved over the years.

It has already been shown that a domestic auto-control system, which continuously adjusts fuel consumption to heat requirements, can show a substantial saving in working cost.

Another improvement in

domestic central heating is in thermostatic valves which provide automatic control for individual radiators. In some installations, this is coupled with an electronic device that relates the warmth of the house with changes in outdoor temperature.

This year's HEVAC, organised by Industrial Exhibitions Ltd., is the biggest ever. The stands occupy an area of 90,000 square feet. In the last two exhibitions a total of nearly 500 exhibitors showed their products to 80,000 trade, industrial and professional visitors.

## WHAT'S NEW FOR HEVAC EXHIBITION THIS YEAR?

The new Capital range of gas-fired small bore units has recently been accepted by the Council of Industrial Design. These boilers, both conventional flue and balanced flue models, will be prominently featured on the **International** stand at the exhibition. They will be shown with stainless steel working top just introduced.

The Gas-Pak 35 and Gas-Pak 50 specially designed for packaged deal central heating but also suitable for estate development will be shown.

Delmore oil-fired boilers are being displayed—the new Series 3 covers a range from 30,000 to 128,000 B.Th.U/hr. All are extremely quiet in operation, odourless and suitable for installation in a kitchen. Available in white or cream stove enamel finish.

A range of International Capital radiators will be shown in single panels, doubles, trebles and quadruples. International are also showing their famous accelerators.

The **Pegus** and **Prunata** heat meters marketed by **Heat Meters Limited**, an Associate Company, will also be shown.

\* \* \*

The **Fenton Byrn** exhibit will highlight the V and D ranges of forced convection heaters which have proved so satisfactory in this field. The DL10—neat and stylish, will be shown

in its less familiar guise—that of a wall mounted unit. Together with the similar DL15 model the two heaters provide for the lower output requirements for normal domestic heating. Both units have almost silent fans.

The higher output units will be well represented with the VE30 and VL30, each giving 30,000 B.t.u./hr., and the VF40 giving 40,000 B.t.u./hr. The V units show well the versatility of the range, being adaptable for many types of system.

The WMC1 and 2 units complete this group, being specially designed for either wall or ceiling mounting.

To prove its particular suitability for the domestic heating field, one of the VL units will be shown with the new dark Sapele wood surround.

Fenton Byrn wall fans are also being shown in their 6", 9" and 12" sizes.

\* \* \*

**Radiation Central Heating Ltd.** will be showing their latest range of Ductair gas-fired central heating appliances. Also on view will be the Ductair G 3503 (balanced flue model) which was introduced to the public at the Building Exhibition in November last. The unit has an output ranging from 30,000 to 35,000 B.t.u./hr.

A unique feature of the G3503 and its conventional flue twin, the G3501, is that if after installation a higher level of heating is needed, it can be simply and quickly converted to a Ductair G4503 (or G4501 in the case of the conventional flue model), which has an output ranging from 40,000 to 45,000 B.t.u./hr. Conversely, the G3503 can be derated by 5,000 B.t.u./hr. in order to provide an economical heating system to match individual requirements.

Radiation Central Heating Ltd. are also showing their well-known Flat-Pak metal ducting which greatly simplifies and reduces the cost of installing ducting for warm air central heating systems (January Engineer). They are also exhibiting the Parkray, G301/2, a gas-fired small bore central heating unit which has a unique system of fuel saving controls and can be mounted on the wall, thus saving valuable floor space for other kitchen appliances. The popular Parkray 77 solid fuel room heater will also be on show.

\* \* \*

Among the control units for domestic and industrial use to be shown by **Venner Limited** are the new radiator fan control and the Multiset timer. The radiator timeswitch provides automatic fan operation at pre-set heat output levels. It is particu-

*Continued overleaf*

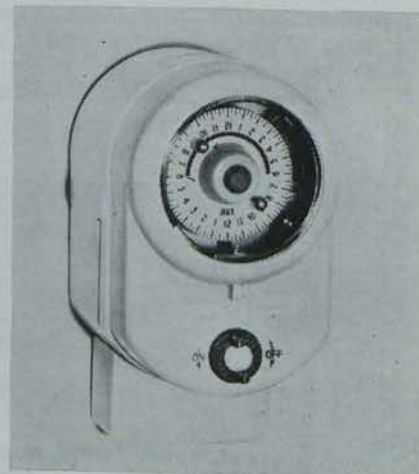

**This is the new Vennerette Mark II. Domestic Time Switch.**

Five



*The Irish Plumbing and Heating Engineer.*

arly suitable for use where morning and evening "boosts" are required from the convection storage heating system to provide warmth before leaving and on returning to the house.

The new Multiset is suitable for a wide range of applications, having been designed for circumstances where switching periods of varying duration over a 24-hour cycle are required. These include kindling control for solid fuel heating systems, and the automatic control of heating, lighting and feeding systems for the development of farm livestock.

\* \* \*

**B.S.A. Harford** exhibits at the exhibition will feature two new products. For the time in this country B.S.A. Harford will be exhibiting their newly announced Opixy glandless accelerator. This new accelerator has been designed specifically for the medium and smaller sized installation and has an output of up to 5 g.p.m. at 1ft. head. It is a particularly attractive looking pump and is fully adjustable to any duty, before or after installation, by easily accessible selector.

It has a push button clutch device to free the shaft when necessary, a vent screw, a high overall efficiency and specially designed water lubricated bearings. It can be installed with shaft either horizontal or vertical. The weight of the Opixy is only 9lbs. 12ozs. and it can withstand a static pressure of 22lbs./sq. ins. The revolutionary new pump will not be available in quantity until later in the year.

The other new B.S.A. Harford product is the range of B.S.A. Harford steel panel radiators which was announced in March. These attractive radiators are tested to 100 p.s.i., made from 18 gauge mild steel and finished in non-metallic primer. They are

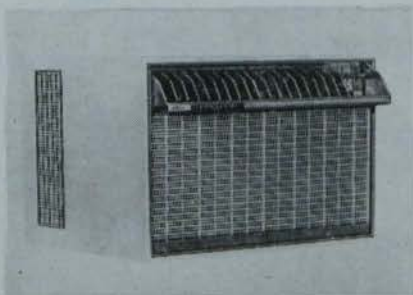

**This compact room heater is particularly suitable for smaller domestic or light commercial applications. By**



*from previous page*

available as single, double or treble panels with such extras as shelves and clip-on towel rails.

Other products to be exhibited include the B.S.A. Hotspur domestic central heating boiler; the TA twin action radiator valve; the Kosmos Thermostatic radiator valve; the Opiomatic variable output glandless circulating (accelerator) pump; the Opio High Duty range of pumps; and the Mixford Shunt Valve (VTR).

\* \* \*

A baby balance-flue gas space heater, Type 651, is a new exhibit from **F. A. Borchardt Ltd.**, a firm which has recently joined the United Gas Industries Group. The new heater is described as ideally suitable as a wall-mounted hall heater. The firm shows a range of 17 heaters, from 17 to 114 cu. ft./hr.

One of the Copperad exhibits at Olympia will be a new radiator of particularly elegant design. It is the Corinthian, made of pressed steel and conforming to British Standards specification. Its lines are strictly classical.

Other "first time" exhibits on the Copperad stand are a new curved-forward impellor centrifugal fan, completing the company's range, a new disc humidifier, and an unusually-designed flat-fronted Sill-line convection heating strip.

\* \* \*

**Steel Radiators**, who produce 34 basic sizes of radiators in three different styles (column, panel or Nuvello) are featuring the Stelostat thermostatically controlled radiator valve, giving accurate control over individual room temperature.

One of the Tempair products is claimed to be the world's only truly portable air conditioner, which can be used as a personal cooling unit or space heater for use indoors or out, in offices, bedrooms, yachts. The versatility of the unit is exemplified by the fact that it can be used to temperature control radio equipment.

\* \* \*

A diffuser which can be simply adjusted for volume, direction and distribution is a new item shown by **WATERLOO GRILLE**. The company also shows a combined weather-proof grille and automatic damper for natural ventilation of tall buildings.



**The new one-piece Fulwood wash basin.**

## Ideal hotel room fitting

**A** PART from those in the luxury class, relatively few Irish hotels have guest rooms equipped with wash basins of really adequate size. In the majority, however elegant the wash basin installation, toiletry items must be placed on a frequently inadequate glass shelf, or balanced precariously on the wash basin. In either case there is always a danger of articles falling into the basin.

**A new one-piece wash basin unit—"The Fulwood"**—in ceramic glazed fireclay, now puts an end to all such inconvenience and risk, providing both hotelier and guest with all the advantages of a made in several pieces unit but at lower cost. Rectangular in shape, it measures 42" x 21" overall, half of its length being moulded to provide a flat toilet-table surface, about 16" wide. A raised shelf extends along the full length of the back of the unit.

The wash bowl is slightly elliptical in shape with its top edges slightly below the level of toilet table to facilitate easy disposal of all surplus liquids. The bowl is designed to take a corner mixer fitting with pop-up waste, but normal pillar taps at 4" centres can be supplied if required. Supporting brackets are concealed by a neat wooden frame, one portion of this frame is cut away to form a towel holder, and the whole forms a most compact unit fully in keeping with the best of modern design.

● A Preview of more new products for the HEVAC Exhibition appears in the industrial section of this issue.

# See **Sanbra Fyffe** first

FOR ALL REQUIREMENTS IN PLUMBING AND HEATING SERVICES

THE SANBRA FYFFE RANGE INCLUDES:—

- CONEX - INSTANTOR Compression Joints and Fittings for Copper Tube.
- Valves, Stopcocks and Drawn Copper Traps.
- SANBRA FYFFE Brassware—including the renowned 'Easilyne' and 'Aqualyne' Luxury Taps and Fittings—as well as Pillarcocks, Bibcocks, Wastes, Plugcocks, etc.



SANBRA FYFFE products are approved by the leading Architects, Surveyors, Plumbers, Contractors, Government Departments, Municipal Authorities and Water Works throughout Ireland.

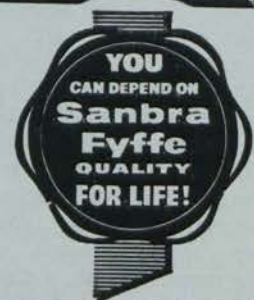

SANBRA FYFFE LIMITED, CONEX WORKS, SANTRY AVENUE, DUBLIN, 9.  
Telephone: Dublin 375131 (5 lines).      Telegrams: SANBRA, DUBLIN.      Telex: 5325.

## THIS IS FLAMELESS HEAT

CATALOR LIQUID-GAS thermo-reactor for domestic, office or industrial heating.

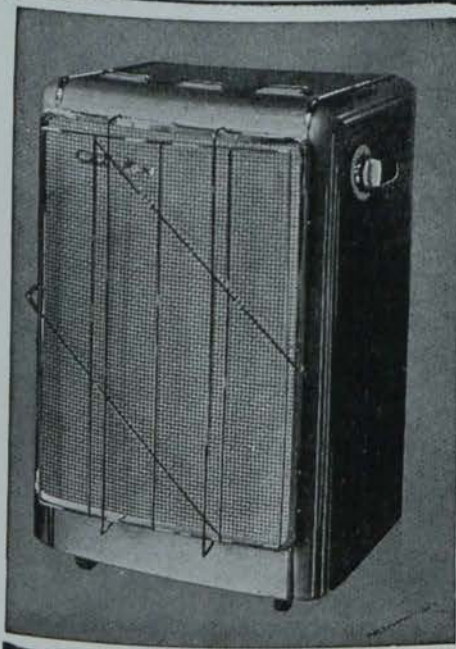

"Catalytic Heating"—What It Means And How It Works. When liquid propane or butane meet a pre-heated platinised "catalyst" they are oxydised into carbon dioxide and steam; heat is generated in the process, and the (patent) "CATALOR" heater gives off this heat as 46 per cent. radiation and 54 per cent. convection. The heating element does not ignite or glow; it simply pours out penetrating heat which is healthy, clean and SAFE. Even a naked flame held near the CATALOR element is extinguished. The larger models need only a few minutes of electric pre-heating; then an automatic cut-out switches off the current as the element grows hotter.

Left: Model 6035 CATALOR 'Housemaster' Domestic Heater, £25-12-0.

NO PIPES OR WIRES

CATALOR Heater is self-contained, holds butane or propane bottle, runs on smooth castors.

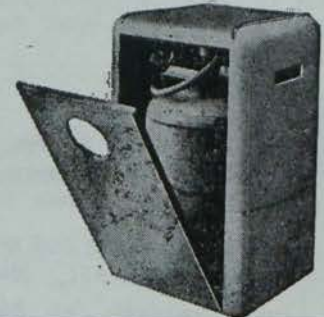

## W. & L. CROWE LTD.

East Wall,  
Dublin, 3.  
Phone 43101.

Sole Distributors of CATALOR (Patent) Liquid-Gas Heaters throughout Ireland.

# the 7 deadly sins of domestic installation



**L**AST month I wrote that some people preferred to carry out their survey before submitting an estimate, while others have a quick look over the job, submit their estimate, and only go ahead with a survey and design when they are sure of the business.

There can be good reasoning behind either approach. If the survey and design is carried out first, then, of course, the estimate may be really accurate, and difficulties should be foreseen. On the other hand the work may be wasted, someone else may come in with a keener price or you may have made the fatal error of trying to sell more than your prospective client can pay for. Also it is not unknown for an unscrupulous client to take a design, submitted with an estimate, to some third party who will use that design as the basis of a lower price.

If the survey follows the estimate then pricing cannot be really accurate although with experience it is usually possible to work out a quick estimating system for small jobs and, of course, to check how the system is working on every job. This is probably the best approach for the small firm, where the principal carries out designs and costings himself. The time of such a man is usually so precious that he just cannot afford to spend much of it on work that may prove unfruitful.



I have heard it argued that there is no need for a survey and detailed design before carrying

out a domestic heating installation. Certainly the survey may be omitted if you have accurate, up-to-date plans as one would with a new house. However, unless you are the sort of genius who can work out heat losses and pipe sizes on the back of an envelope and then set out pipe runs on site for the fitters, a design is essential. Anyway, you can't take off quantities from the back of an envelope.

The site survey is therefore necessary in almost all cases where no house plan exists and our second "deadly sin" is to let ourselves and our client down by failing to do this properly.



**CARRYING OUT A SITE SURVEY.**—The purpose of a site survey is to get certain essential information that will be needed for the design. It will be necessary to know:

- (a) The plan of each floor with joist runs and any level variations.
- (b) The construction of walls, floors and ceilings together with the window areas so that heat losses may be established.
- (c) The height of all rooms.
- (d) The location and condition of the flue (if existing) that will be used for the boiler or air heater.
- (e) The preferred location of components such as boiler, hot water cylinder, radiators, etc.
- (f) The size and extent of possible working areas such as roof or underfloor spaces.
- (g) The location and condition of any existing work, or components,

that may be linked up with the new work, for example, a storage tank, hot water cylinder or supply pipework.

- (h) Any special access difficulties for men or materials.

There are certain other requirements that occur on most jobs but not all; for example, since radiators mostly go under windows, it is usually necessary to note cill heights. Most systems will require an electrical supply, and it pays to check the voltage and the availability of power points. If an oil-fired boiler or heater is to be used, then the oil tank location should be noted; if a gas-fired appliance is to be used, then the size of the supply pipe should be checked.

All this looks a bit complicated, but it isn't. Most of these points are covered almost automatically if you work to the right system and with the right equipment. I have found that the following list of equipment is about right for a survey:—

- (a) Linen tape measure, preferably 66 feet.
- (b) A folding rule or a stiff steel tape. A two foot rule is not really long enough to check ceiling heights.
- (c) A board of suitable size with a supply of graph paper (preferably  $\frac{1}{4}$ " squares) together with pencils, rubber and notebook.
- (d) A good-sized torch (with a mirror for examining the flue).
- (e) A spirit level.



In addition to this, it gives the client a good impression and may save personal damage if you bring your own step-ladder. An assistant to hold the other end of the tape is not absolutely essential—a rubber suction cap on the tape holds just as well and doesn't ask awkward questions!

In measuring up I was always

**THIS sparkling and well-informed series is by W. J. R. COUCHMAN. His name will not be unfamiliar to many readers, as Mr. Couchman maintains close contact with the trade throughout Ireland and is ideally informed to compile this new series.**

Eight

# domestic installation

from previous page

taught to work from the left to the right and to take running dimensions; in other words, each dimension along a wall is shown as the distance from that point to the left-hand corner. It is quicker and clearer to write feet and inches, thus, 2/11 rather than 2' 11". Joist runs are indicated by close parallel lines crossing wider spaced parallel lines which are the floorboards. Four lines to a room are enough to show joist runs. Steps are indicated by a line for each step with an arrow for the fall and a figure for the height. The "hang" of a door should always be indicated.

A sketch plan is made up as you go along; the squared graph paper helps. If all four walls of a room are measured this is self-checking since widths and lengths are measured twice over; the extra time spent in this case is justified. One soon works out a system of symbols which save time; for example, a window may be indicated by a "W" between the two dimensions; cill height is "C" followed by a dimension, window height from cill to head would be "H," a fireplace would be "F," and so on.

The whole thing boils down to a sort of shorthand; the precise form of shorthand is not important, provided it can be understood afterwards. Without a system like this it can take all day to survey a small house; using such a system it takes about an hour and a half to take off sufficient details for a really accurate plan.



One picture is worth a good many words. On the right you see part of a rough sketch made up on site; you can see how the graph paper gets it roughly to scale. The finished drawing below the rough shows that there is no need for an elaborate job. It is tempting to cut out the double lines for the walls; some people do this and save quite a bit of time. I would not recommend this since the scale is bound to become inaccurate and you may end up trying to mount a three-foot radiator on a two-foot run of partition.

At some point in this series I should say firmly that a trained draughtsman

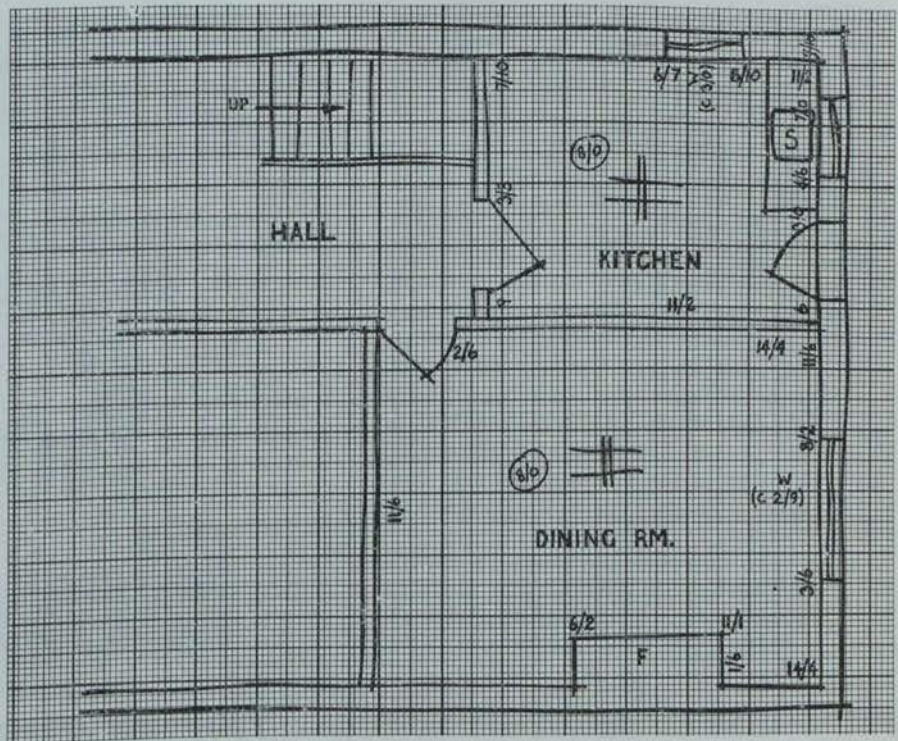

working drawing. A good drawing board helps but even this is not essential. I have worked in my own home with a glazier's square on the top of my wife's kitchen cabinet. Draughtsmen normally work in pencil or ink on semi-transparent paper or linen. The finished drawing is treated as a photographic "negative" and prints are taken off as required.

The average installer usually needs only two copies of a drawing—a fair copy for the customer and a quick tracing for his own use. It is better not to use pencil for the customer but Indian ink and drawing pens can be a bit tricky for the uninitiated. One way of quickly producing a good-

Continued overleaf

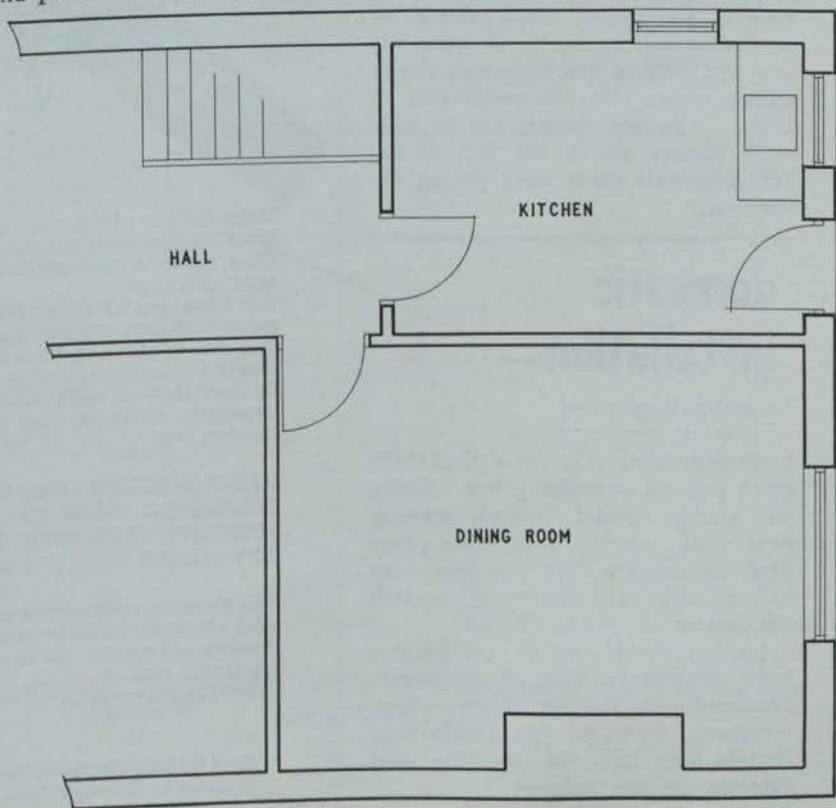

The Irish Plumbing and Heating Engineer.



A SYNDICATE formed in Dublin has paid £60,000 for the share capital of Sheet Metal Industries at North Circular Road, Tralee. Mr. John Patrick Fealy, the man who stated the industry in 1936 with only £15 in his pocket, has retained a substantial holding in the business and will continue with the company as managing director.

The company has plans to expand the factory to about three times its present size. Among the factory's products are water fittings and gutter pipes.

\* \* \*

A NEW "Gate Valves" leaflet (W.473) has recently been released to the trade by Sperryn & Co. Ltd., Moorsom St., Birmingham, 6. Produced to the A4 size and classified for SFB system, this leaflet is the fourth of a new series of standardised leaflets covering the range of Sperryn water fittings.

\* \* \*

BALLYLUMFORD, on the Islandmagee shore of Larne Lough, will become the largest single electricity producing unit in the North when the new £15 million, 360 megawatt power station comes into full production in 1970. The new station will be built on a 70-acre site to the left of the 125 megawatt plant built during the last war.

## domestic installation

from previous page

looking drawing is to use a black ball-point pen on cartridge paper. Better still are the special fountain drawing pens with tubular nibs, since they need no dipping they are very easy to use and they come in various thicknesses.

Incidentally, if any of my readers have encountered one of my home-produced, as distinct from office-produced, drawings, this article may explain why it is the drawing had dripping on the underside.

(Another article next month)

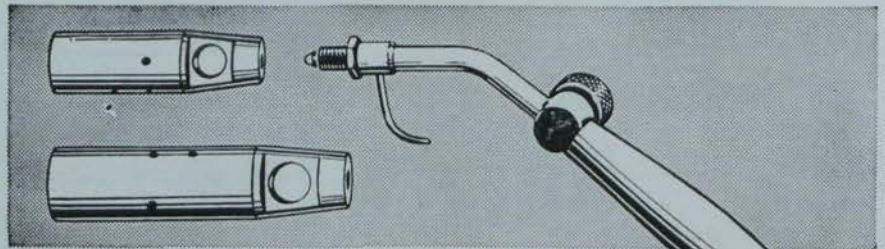

(TH3) (TH4) Kosangas High Pressure Blow Torch. Wooden handle. Needle control valve, for gas adjustment. Supplied with large or medium burner heads.

# Kosangas Blow Torches

*for every plumbing job!*

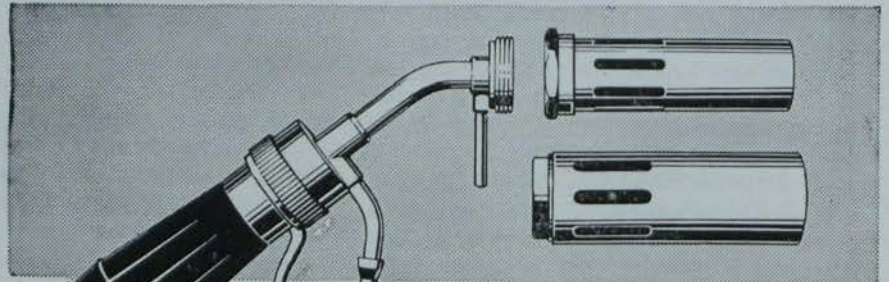

Bullfinch Mark II Blow Torch. New, patented, trigger valve, leak-proof, never needs adjustment. Micrometer bye-pass, saves £££'s on gas. Complete range of burners.

Make full use of the wide range of Kosangas blow torches, available for plumbing work. They're much more efficient than the conventional type.

The Kosangas TH3 and TH4 are designed for paint burning, pre-heating and soldering. The Bullfinch Mark 2 has a wide variety of heads, including soldering attachment. In conjunction with the small portable Kosangas cylinder, use Kosangas blow-torches for:

- PAINT BURNING · PRE-HEATING
- SOLDERING · ROOF FELTING
- JOINTING OF PLASTIC PIPES
- ANY OTHER HEATING NEEDS

The Kosangas plumber's portable furnace, with wind protected burner, is excellent for outdoor plumbing and cable work, requiring liquid asphalt, pitch, zinc, lead, tin and other fusible materials.

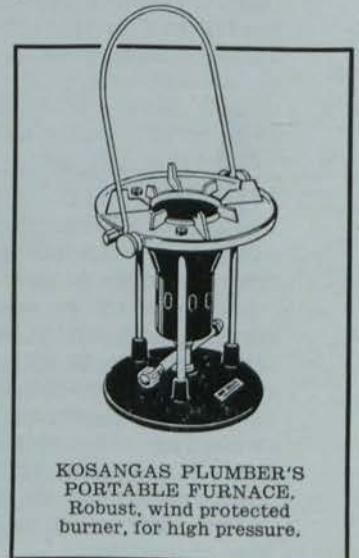

KOSANGAS PLUMBER'S PORTABLE FURNACE. Robust, wind protected burner, for high pressure.

Send for fully descriptive lists and leaflets to:  
McMullans Kosangas Ltd., 1, Upper O'Connell St., Dublin. Tel. Dublin 40761-4.

# solders and soldering

**S**OLDERS have been used for many years in the plumbing trade for making wiped joints in lead pipes. Even though the modern trend is away from lead pipes, solders are still finding use in the modern capillary fittings which are used with copper plumbing.

This article does not set out to describe the methods of making soldered joints in pipes since it is assumed that the reader already has the practical knowledge of making both the old type of wiped joints and the newer capillary joints. What this article does set out to do is to give the reader an understanding of the general principles underlying the use of solders, and to show him how these principles apply in the particular cases met with in the plumbing trade.

having between 50% and 60% tin are closer to the eutectic composition and have comparatively short melting ranges being less than 30°C.

**Antimonial and Non-Antimonial Solders.**—The ores of antimony occur naturally associated with the ores of lead and tin, and thus it is inevitable that a certain amount of antimony occurs in solders. In most cases, this has a beneficial effect on the physical properties of the solders. However, when it is required to have a free-running solder on copper or to have strong joints between zinc or galvanised articles, it is essential to have a solder with a low antimony content.

**T**HUS, solders are manufactured in antimonial and non-antimonial grades. Table I. summarises the different grades of solders as laid down in British Standard Specification No. 219.

**Effect of Impurities In Solders.**—Solders are very sensitive to the presence of certain impurities which make the molten metal sluggish or gritty, or cause it to dross excessively. For this reason, it is always advisable to purchase top quality solder from a recognised supplier rather than to use a cheaper impure solder.

Zinc and aluminium even if present in solder in very small amounts (say 1 part in 30,000 parts) cause excessive drossing of the molten metal. Copper and nickel when present in slightly greater amounts will cause the metal to become gritty and less easily worked.

*Continued overleaf*

**Composition of Soft Solders.**—

First, it is necessary to have a knowledge of the composition of solders. These are essentially mixtures (or alloys as they are termed in the metallurgical world) of tin and lead. Pure tin melts at a temperature of 232°C. Above this temperature, pure tin is always liquid, and below it is always solid. Similarly, pure lead melts at a distinct temperature, 329°C. When tin and lead are alloyed together the solder produced can have a melting point as low as 183°C. The actual melting point depends on the proportion of tin to lead as shown in the diagram.

By . . .  
**D. P. SMITH, Ph.D., A.R.S.M.,  
D.I.C. \***

temperature. Between these two temperatures a solder will exist as part liquid and part solid and will have a pasty consistency.

Reference to the diagram indicates that solders having between 20% and 30% tin have a wide pasty range extending over 70° to 90°C. Solders

**T**HE solder containing 63% tin, 37% lead, has a sharp melting point at 183°C. This composition is termed the eutectic composition, which means that this particular alloy has the lowest melting point of all the tin-lead alloys. The other solder compositions do not have a sharp distinct melting point. Instead, they melt over a range of temperatures. The temperature at which a solder starts to melt is termed the solidus temperature. Below this temperature, it is completely solid.

The temperature at which a solder finishes melting, or above which it is completely liquid, is termed the liquidus

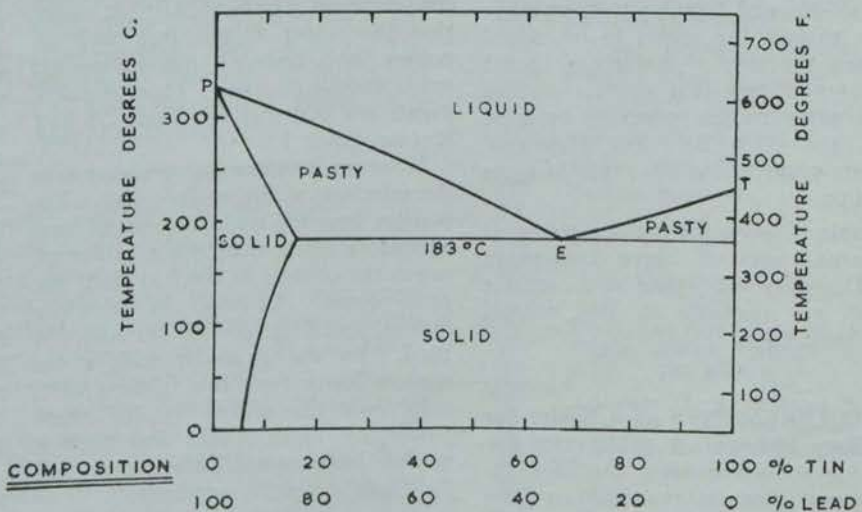

This diagram shows the dependence of melting temperatures on the composition of a solder.

\* Research Metallurgist with Fry's Metal Foundries Limited.

**Table I—GRADES OF SOLDERS FOR GENERAL USE**  
(As specified in British Standard Specification B.S.219)

B.S. Grade	Tin Content		Antimony Content		Lead Content	Melting Temperatures			
	Max. %	Min. %	Max. %	Min. %		Solidus °C	Liquidus °C	Solidus °F	Liquidus °F
A	65	64	0.6	—	Remainder	183	185	361	365
K	60	59	0.5	—	Remainder	183	188	361	370
B	50	49	3.0	2.5	Remainder	185	204	365	399
F	50	49	0.5	—	Remainder	183	212	361	414
M	45	44	2.7	2.3	Remainder	185	215	365	419
R	45	44	0.4	—	Remainder	183	224	361	435
C	40	39	2.4	2.0	Remainder	185	227	365	441
G	40	39	0.4	—	Remainder	183	234	361	453
H	35	34	0.3	—	Remainder	183	255	361	491
L	32	31	1.8	1.7	Remainder	185	243	365	469
D	30	29	1.7	1.0	Remainder	185	248	365	478
J	30	29	0.3	—	Remainder	183	255	361	491
V	20	19	0.2	—	Remainder	183	276	361	529
N	18.5	18	1.0	0.75	Remainder	185	275	365	527

## solders and soldering

from previous page

### Requirements of a Plumber's Solder.

—A solder which is used for making joints in pipes or cables must have a long pasty range, that is, it must have a long range of temperature between the solidus and liquidus temperatures. This enables the solder to be wiped around the joint. Reference to the diagram shows that solders having long pasty ranges contain between 20% and 35% tin. All plumbers' solders occur within this range of composition.

Table II. gives the melting temperatures and uses of three commonly used grades of plumbers' solders which are available in the normal 1lb. stick form.

**REQUIREMENTS of a Solder for Capillary Fittings.**—A solder used for making joints between capillary fittings and pipes is required to have different properties from a wiping solder. In capillary fittings, as the name implies, there is a narrow gap between the fitting and the pipe, along

which it is required that the solder should flow. One relies on the force known as capillary attraction to draw the completely molten solder up into this joint-gap. Ideally, the width of the joint-gap should be between 0.001" and 0.008". Outside of these limits, capillary attraction will not be able to draw the molten solder into the gap.

Thus, the solder used for soldering capillary fittings must become completely molten in order that it should penetrate into the joint gap. A solder with little or no pasty range will therefore be most suitable. Also, in order that the solder should flow well on copper and brass, a non-antimonial grade should be used. These requirements are best met by Grades A and K (see Table I).

However, another factor comes into the selection of the solder—cost. Tin is more than ten times the cost of lead and more often than not a solder of lower tin content is used to keep the price down. Usually, in capillary fittings, therefore, a 40% tin solder is used. To use a solder with a tin content lower than this is more difficult since the solders in this range have long pasty ranges and need a greater temperature before they will flow into a narrow capillary.

**Cost of Solder.**—Even though a plumber's solder is cheaper to buy than the solder used in capillary fittings, the amount of solder used in a

wiped joint is many times greater than the amount used in an equivalent capillary joint. Thus, the material cost is far less for a capillary joint and at the same time there is also a saving because a capillary joint is more quickly made than a wiped joint. These factors, coupled with the increasing use of copper pipes for plumbing, have increased the popularity of capillary fittings.

**Mechanism of Soldering.**—No matter which type of joint or which grade of solder is used, the mechanism of soldering is identical. The joining of metals by solders depends on the inherent property of tin to alloy easily with the surfaces of other metals. This "tinning," as it is termed, is a metallurgical bonding due to atoms of the tin penetrating into and alloying with the atoms of the other metal.

**I**N order that "tinning" should take place readily, the surfaces of the parts to be joined should be clean. Even though, to the eye, the parts are clean, there is always a thin oxide film present. This has to be removed before the solder can come into intimate contact with the metal and "tin" it.

Thus, we can now see why a flux is required. A flux has two functions during soldering. Firstly, as we have just seen, it removes the oxide film from the parts to be joined and secondly

Continued page twenty-six



# trade Topics

**A FRENCH MONSTER BOILER** weighing  $1\frac{1}{2}$  times as much as the Eiffel Tower and with the dimensions of the Arc de Triomphe is being built by Societe Francaise des Constructeurs

Babcock et Wilcox for Electricite de France.

This 600 MW boiler single hearth unit will be the largest in Europe and the fourth largest in the world. The steam space will be 40 metres long and the section under pressure will have 260 kilometres of tubing.

The boiler will be oil-fired and of natural circulation. Rating will be 1,815 tons an hour of steam, the absolute working pressure 191 bars and absolute pressure at superheater output 167 bars and at reheater output 36.4 bars. Steam temperature at superheater output will be 567 deg. C., at reheater output 566 deg. C. Oil consumption will be about 3,000 tons every 24 hours.

To prevent corrosion resulting from oil-firing, Babcock will incorporate its own-designed techniques. The final reheat section will, for example, comprise 3,300 independent closed tubes acting as a boiler from flue gas contact, similar to a condenser working by contact with air. Additionally, combustion will be carried out with a very slight excess of air.

\* \* \*

**A NEW KENT ROTAMETER** GEORGE KENT (Stroud) Limited, manufacturers of Veriflux electromagnetic flowmeters, announce the introduction of the Model 200 Kent rotameter. The

Model 200 is the first of a comprehensive range of variable-area flowmeters now under development by the Company.

Designed for general industrial use, the Model 200 Kent rotameter is a glass-tube type instrument suitable for indicating the rate of flow of liquids and gases. The meter frame is robustly constructed to withstand pipeline stresses which are isolated from the heavy-wall, borosilicate glass met-

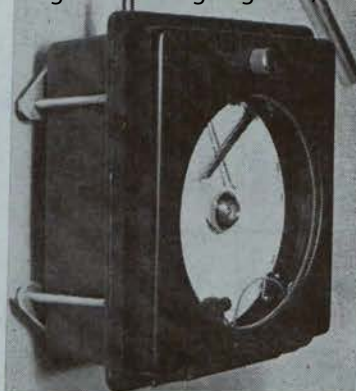

## Addition to Rototherm range

**T**HE British Rototherm Co. Ltd., of Merton Abbey, London, have now introduced to their wide range of instruments a new metal cased Mercury in Steel Temperature Recorder, featuring a small 6" diameter chart. The use of this recorder considerably increases savings in panel space. The instrument may be had in a panel mounting, wall mounting, or portable model.

The most obvious advantage of such an instrument is, of course, for outdoor portable work, where a weatherproof, medium sized, durable recorder is essential. The instrument is fitted with a spring wound clock, and so needs no mains supply, and can be left unattended for several days. Our illustration shows the panel mounting model, whose neat, attractive, clean lines would grace any panel.

The new model is available in any of the standard Mercury in Steel Temperature ranges from  $-30^{\circ}\text{F} \times 1200^{\circ}\text{F}$ , and equivalent centigrade, with either 12hr., 24hr., or 7-day chart rotation. Irish agents are The Rototherm Precision & Instrument Co. Ltd., Beechwood Works, Killynely, Co. Dublin.

ering tube by carefully designed tube sealing arrangements. A wide range of flows of different fluids can be accommodated in any one meter frame by interchanging either metering floats or metering tube and metering float combinations.

A variety of materials of construction is available, permitting the handling of many aggressive fluids. Vertical or fully rotatable screwed and flanged connections are offered. Irish agents are S. W. Carty & Son.



## Industrial heating & ventilating — IN IRELAND

THIS MONTH the industrial section looks at how a new approach is solving many old problems associated with reducing heat loss from process liquids. Author of this article is J. Haines, B.Sc.

Daniel Heeney continues his series of articles under the heading Mechanical Refrigeration To-day. In part three of his series he deals with refrigerating equipment.

An extended Preview look at the forthcoming HEVAC exhibition occupies much of the industrial section this month. We'll have our own correspondent at Olympia and his exhibition reports will make further highly informative reading.

Trade Topics cover the month's News.

NUMBER 3 — Presented with the March, 1964, issue of the Irish Plumbing and Heating Engineer.

Editorial and advertising offices:

Callaghan Chambers, 13/15  
Dame Street, Dublin 2.  
Tel. 56465-6.

London: J. T. Robson &  
Son Ltd., 30 Fleet Street,  
London, E.C.4. Tel.: Fleet  
Street 4438.

Belfast: Allen McDowell,  
43 Horn Drive, Belfast 11.  
Phone 614606.



**M**OST industrial processes involving liquids take place in closed vessels, but there are still many processes where treatment must generally be carried out in open tanks. Degreasing, hot rinsing, electro-plating, anodising, dyeing and acid pickling are examples.

Heating costs represent a substantial proportion of the total process cost in these situations. Often this figure is not accurately known because steam or other heat sources are not, for obvious reasons, metered on an individual tank. Even where an accurate figure is available, the heat losses in financial terms are unknown.

Often the need to work with open process tanks has meant that powerful extractor systems have to be used to remove noxious fumes, and in the past, this has severely hampered heat conservation by increasing heat losses by convection.

Other problems arise in connection with the use of open liquid process tanks and these can often be as important when their true magnitude is appreciated as heat loss, e.g., evaporation losses, condensation, corrosion, oxidation, fumes, splashing and "spray" of hot aggressive liquids, boiler loading during adverse weather conditions or where capacity is expanded and even trying to achieve optimum operating temperatures.

The patented "Allplas" system introduced by Capricorn Industrial Services Limited, of 49, St. James's Street, London, S.W.1, represents a new approach in dealing with these problems. The idea is a simple one and consists of floating a blanket of hollow plastic balls on the liquid surface which, thus, acts as a floating lid. Each ball has a diameter of  $1\frac{1}{4}$ " and is made from Polypropylene, a highly resistant plastic which can withstand temperatures from  $-20^{\circ}\text{C}$  to above  $100^{\circ}\text{C}$  and which is resistant to most inorganic solutions and a great many organic solutions.

**T**HE balls form an almost continuous blanket with 50 balls required to cover one square foot. At this density, 80% of the surface is covered by a single layer of balls, but rather surprisingly, the economies achieved are greater than might be expected.

Experiments carried out by the National Engineering Laboratory of the Department of Scientific and Industrial Research, East Kilbride, Glasgow, have established that, to maintain water at a constant temperature of  $90^{\circ}\text{C}$  in a tank with a surface area of  $20\text{ sq. ft.}$  but only 4.34 kwH.

# reducing heat loss from process liquids



# new approach to old problems

with one layer of "Allplas" balls. This represents a saving of 69.5% in heat input. A second layer of balls raised savings to nearly 80%.

Ambient temperature during these experiments was  $20^{\circ}\text{C}$ . In addition, these experiments confirmed a considerable reduction in the rate of evaporation. In the case of water, the loss at  $80^{\circ}\text{C}$  was 1.54 lbs. per sq. ft. per hour from a free surface, but only 0.182 lbs. per sq. ft. per hour from a surface covered by a single layer of balls—a reduction of 88.3% in the

evaporation rate. These findings have subsequently been confirmed by the Research Department of London Transport.

These figures assume efficient heating and good lagging of the sides of the tank since "Allplas" obviously cannot deal with these problems. By reducing convection losses, "Allplas" can, however, give a better result where extraction systems are used.

**N**ATURALLY, while experimental data from research units is extremely valuable, industrial companies are concerned with the practical results achieved in terms of money saved.

Camplings Limited (Launderers) of Great Yarmouth installed "Allplas" on their open boiler feed water tank. The tank is of brick construction with a surface area of 54 sq. ft. The addition of "Allplas" has raised the average water temperature by a minimum of  $30^{\circ}\text{F}$  to a near ideal level of  $190^{\circ}\text{F}$ . While no accurate estimates of the fuel savings are available, it was estimated that this represented a minimum saving of one ton of coal per week, if three shift working was employed.

Another application was on the phosphating line of K. & L. Steel-founders Limited. While the lid could be used at night to retain process heat, due to the nature of the phosphating process, lids could not be used effectively during the phosphating operation. Before the adoption of "Allplas," in spite of the intensive use of extraction systems working conditions were still not ideal.

**S**INCE "Allplas" was adopted, as the extractors are now used less intensively, working conditions have improved. In addition, whereas in the past, two gas burners were needed to maintain the operating temperature at  $195^{\circ}\text{F}$ , now only one burner is needed with the valve only a quarter open.

Since the range of "Allplas" users include large combines and small companies, chemical companies, food processors, ferrous and non-ferrous metal processors, laundries, laboratories, printers, textile processors and municipal authorities, it will be appreciated that like the heating engineer, the "Allplas" system apparently has no industrial boundaries.

*This article was compiled for the I.P.H.E. by J. Haines, B.Sc., director of Capricorn Industrial Services Ltd.*

*Technical sales agents here for Capricorn are Halpin & Hayward Ltd.*

ANY IDEA WHERE I CAN  
FIND BIDDLE?

SURE!

IN COVENTRY CATHEDRAL, SHELL CENTRE SOUTH BANK,  
QUEEN ELIZABETH II HOSPITAL WELWYN GARDEN CITY,  
LONDON AIRPORT, THE OLD BAILEY, ROYAL COLLEGE OF ART,  
THE BRITISH MUSEUM, ROYAL FESTIVAL HALL, VICKERS  
HOUSE, LEADING BUILDINGS ALL OVER THE WORLD, AND AT

# STAND 258

HEVAC  
1964

SEE YOU AT THE SHOW



 <p>Good-looking Conrad is smaller than normal radiators with the same heat output and takes half the time to install. Fits under the majority of window sills and is so light that it can even be hung on partitioning. A successful marriage between a radiator and a convector, giving a good even temperature from floor to ceiling... no uneven stratification. Easy to install and clean; no need to remove for redecoration of premises. Operates on two pipe accelerated hot water systems, has a quick heating-up response, and very good radiation effect at low temperatures... 3" deep, 22" high, 24" to 72" long, in 6" increments.</p> <p><b>conrad</b></p>	 <p>Trim, elegant Forceflo is ultra quiet, with a guaranteed noise criteria rating under any conditions. Specify Forceflo when you have sound level problems because Forceflo is the only unit tested through all audible frequencies. There is a variety of sizes, outputs (up to 62,000 Btu/h) and designs: free-standing, concealed, remote and ceiling mounted. Standard Forceflo is 28" high, other heights are in production and readily available for all applications</p> <p><b>forceflo</b></p>	 <p>New, completely redesigned Torridaire gives you full 5-speed control and up to 1,750,000 Btu-h &amp; 18,500 C.F.M. Eight basic sizes cover the gamut of heavy-duty heating applications. With the Biddle coil and a new concept in fan and motor design, these units require virtually no servicing. Through new development techniques, vibration has been eliminated. The new design has effected a weight saving of 50% over the centrifugal type.</p> <p><b>torridaire</b></p>	 <p>Warmline skirts the perimeter of a room to supply unobtrusive warmth. Damper control for each panel length optional. Three heights (12", 16", 20") are available offering a high heat emission per foot run. Heat is evenly distributed over the run allowing room partitioning without interfering with output. The copper primary tubes are to BS.659, and can be assembled with standard compression or capillary fittings. Mechanical bonding of stamped aluminium fins gives high heat transfer. Special element supports allow expansion with out noise. Easy and inexpensive to instal and maintain. Finished in grey primer.</p> <p><b>warmline</b></p>	<p>Come to the Biddle stand at HEVAC, Number 258. That's where you'll get the warmest welcome, that's where you'll see all that's new in heating and ventilation, all that's exciting in new developments too! There is plenty of literature available on the entire Biddle range, and experts in attendance to answer any enquiries, or to help you on the way to solving any problems.</p> <p>If you are unlucky enough not to be able to visit HEVAC this year, drop us a line and we can still attend to any questions or requests for literature you may have. Address your letter to:</p> <p><b>F. H. BIDDLE LTD.</b> 16 Upper Grosvenor St., London, W.1. Hyde Park 0532</p>  <h1>biddle</h1>
--	---	---	---	---

*The Irish Plumbing and Heating Engineer.*



# A PREVIEW LOOK AT THE 1964 HEVAC

**Trox Brothers Limited**, a subsidiary company of one of Europe's largest manufacturers of air distribution equipment, are exhibiting on their stand this year a comprehensive selection of equipment. Included in their range is a wide selection of grilles and registers manufactured from extruded aluminium, steel and extruded P.V.C. In addition to the proven steel and aluminium grilles featured on the stand, the extruded aluminium return air and linear grilles are new additions and will be of considerable interest.

The existing range of round and square patten ceiling diffusers has been complemented by the addition of a new attractively styled and priced square perforated ceiling panel diffusers.

Of particular interest will be the Trox Multi-Leaf dampers which are again featured, having been recently redesigned incorporating a number of improvements. The Trox Silencer Unit has been redesigned also to give a greater attenuation in the important low frequency range. A selection of external louvres and pressure relief dampers will be featured too.

Irish agents are W. Finucane & Co. of Dublin.

\* \* \*

The "Flo seal" lever operated sleeve valve, which has many interesting features, will be shown for the first time by **HATTERSLEY (ORMSKIRK) LTD.**, of Ormskirk, Lancashire.

The valve is glandless and the synthetic sleeve gives bubble tight closure on air at pressure up to 300 p.s.i. Combined in this patented valve are the straight through flow characteristics of the gate valve, the flow control of a regulating globe valve, and the compactness and quick action of a plug cock.

The "Flo seal" can be installed in any position in the pipe line and with flow in either direction pressure drop is minimal. It is particularly suited to heating and process work, also water and air lines, where its quick action, full flow characteristics and regulating properties will be readily

appreciated by the engineer. The valve is available in  $\frac{1}{2}$ ,  $\frac{3}{4}$ , and 1 inch sizes for either iron or copper pipe.

\* \* \*

Among the features of the **Ivo Engineering & Construction Co. Ltd.** exhibit is the IVO draught stabilizer. This chimney or flue appliance, which the company developed over 30 years ago, was ever since subject to constant modification and improvement. It is extremely sensitive and gives instant reaction to change in atmospheric conditions or change in furnace temperature, ensuring positive draught control and giving maximum combustion efficiency under all conditions. As the stabilizer controls draught by admitting a regulated quantity of cold air into the chimney or flue, the appliance also prevents overheating of same most effectively. In addition, it also incorporates self-righting explosion door, and the front portion of the stabilizer can be instantaneously removed, giving full aperture access door for cleaning purposes.

\* \* \*

Of particular interest to industrial and agricultural visitors to HEVAC will be the **Fenton Byrn** range of motorised roof ventilators. They are featured in glass fibre construction complete with automatic closing shutters, sizes ranging from 12" to 24", and larger sizes are also available. The units are adaptable to most types of roof construction, including corrugated asbestos.

\* \* \*

**The Chemical & Insulating Co. Ltd.** manufactures a range of heat insulating materials and finishes suitable for all industrial purposes. Darlington 85% Super Magnesia—of particular interest to Heating Engineers and Consultants—will be featured on their stand. This precision moulded material is an excellent insulant with low thermal conductivity at all temperatures up to 650°F. It has outstanding strength, resistance to water and vibration, is easy to handle and takes any finish. The precise fit of Super Magnesia and its excellent surface are particularly emphasised.

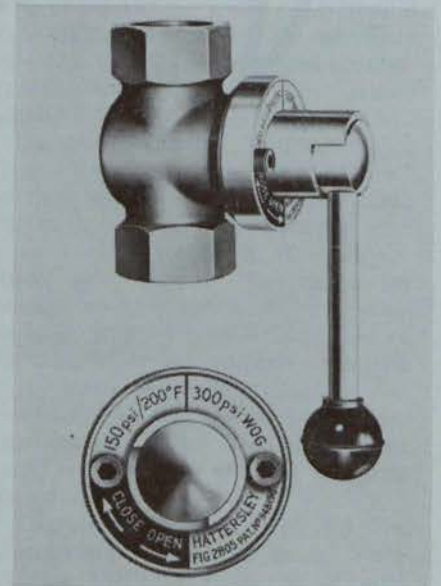

Pictured above is the new Hattersley lever operated sleeve valve. Below is the IVO draught stabilizer (see Preview).



● An HEVAC Preview dealing with products other than those coming under the industrial heading appears elsewhere in this issue.

**Vokes Limited and Vokes Bergen Genspring Limited** are two members of the Vokes Group of Companies who will be showing their products, which have very wide applications throughout the heating and air conditioning field.

Four new products will be featured by Vokes Ltd. The Hospital Renovair Unit Mk. 1 is a mobile recirculating air filter unit for the relief of sufferers from respiratory diseases, now in use by many hospital authorities. The Auto-Vee automatic air filter has been specially designed for use in air conditioning and ventilating systems where space limitations preclude the use of the well-known Autoroll filter.

The Uni-Vee bag type air filter consists of four filter bags available in three grades of material depending upon the particular application and housed in a robust steel holding frame with a front face 24" x 24", which can be drilled for assembly into multiple units. The new Carbon pack filter is designed specially for the purification of foul or stale air by the extraction of all entrained odorous vapours and gaseous impurities; these units are readily adaptable for all air conditioning and ventilating systems.

Other exhibits will include: The S.C. Mk. II. Automatic Rotary Viscous Screen filter which employs a number of specially designed all metallic panels which pass through a trough of oil where a very high degree of self-cleaning is achieved by means of a unique cleansing device incorporated in the trough.

A feature of the Vokes Bergen Genspring Limited exhibit will be their "G" and CSH range of Constant Support Hangers which have many applications for supporting pipe and ducting in power stations (conventional and nuclear), refineries, chemical plants, etc., and, in fact, wherever there is a need for such supports. They carry loads up to 98,000 lbs.

\* \* \*

The stand of **Davidson & Co. Ltd.** will be laid out as a country garden to emphasize their theme of "Selling Clean Air." The garden area, which measures 400 sq. ft., will be backed by an open office area. On the rear wall there is a 20 ft. wide mural showing the air pollution problem in a typical large city.

There will be no plant or machinery on the stand, but the range of Davidson's air treatment equipment is illustrated by large photographs and drawings, showing the various units for heating, ventilating, dust collecting and air conditioning applications in



locations ranging from mines and power stations to small factories and offices.

Products represented include the Sirocco cellular dust collector, a typical large axial flow fan as used

in mines throughout the world, and the "L.D." and "U" series centrifugal fans which are among the most advanced designs of their type.

\* \* \*

Featuring new designs and developments the **Greenwood Airvac** stand exhibit will comprise an extensive range of attractively designed and strongly constructed registers, grilles and diffusers for heating and air conditioning systems, and a complete

*Continued page nineteen*

# A UNIQUE BOILER-TUBE CLEANING UNIT!

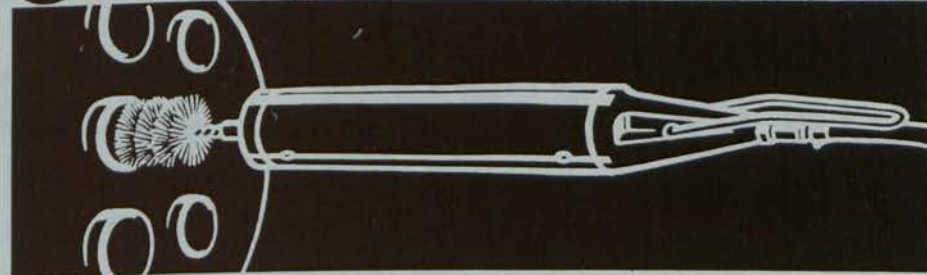

The Ferret is a completely unique type of boiler-tube cleaning unit. Attach it to a standard tube brush and it will creep along the tube — *without revolving* — and without any need for manual pushing and pulling! When it reaches the tube end, the double thrust action then reverses and the Ferret returns — ready for the next tube!

**THE FERRET** \*Cuts labour time—no manual pushing and pulling

\*Does away with extension rods.

\*Gives cleaner tubes.

\*Works quickly.

For full details, or a demonstration in your own plant, contact —

## AIRNESCO PRODUCTS LIMITED

4 New Road, Rochester, Kent. Chatham 42217.

Agents in Ireland: HALPIN & HAYWARD LTD., Unity Buildings, 16/17 Lr. O'Connell St., Dublin, 1 (Phone 48638), and Bedford Buildings, 7 Bedford St., Belfast Phone 26343.



# NEWMAN HENDER VALVES AND FITTINGS

Known throughout the world for the dependability and quality of their wide range of valves and fittings you cannot do better than ask Newman Hender *first* for the valve or fitting you require. Stocks are held in Dublin of many patterns to meet constant and urgent demands.

## VALVES ARE OUR BUSINESS

*... in most types and sizes  
... for most temperatures and pressures  
... for most industries all over the world.*



**NEWMAN HENDER & CO. LTD.**

WOODCHESTER · STROUD · GLOS. · ENGLAND

AGENTS & STOCKISTS

**C. H. LOCKHART LIMITED**

75, MIDDLE ABBEY STREET, DUBLIN Phone: DUBLIN 43487

## VOKES

# offer guaranteed correct solutions to air filtration problems

## VOKES 'RENOVAIR' SMOKE REMOVAL UNIT

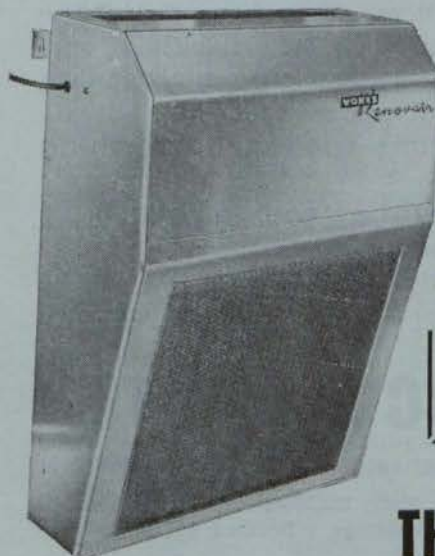

The 'Renovair' is the latest addition to the comprehensive range of Vokes air filters, and is ideal for use in meeting halls, offices, restaurants or any building or room where people congregate. Simply switch it on and it completely clears tobacco smoke and other airborne contaminants from the atmosphere within a few minutes. And

because the Vokes 'Absolute' filter in the 'Renovair' cleans air which is then recirculated, heat loss is eliminated with consequent saving on heating bills. Please write for descriptive leaflet. Other Vokes filters widely used in air conditioning and ventilating applications include:—



S.C.



Super-Vee

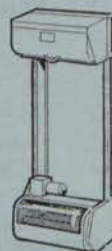

Autoroll

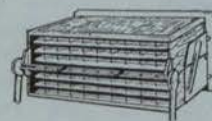

K.600 Kompak

S.C.—A completely automatic filter for handling large quantities of air.

Super-Vee.—An inexpensive expendable filter panel suitable for many industrial applications.

K.600 Kompak.—A high-efficiency filter unit with replaceable filter medium.

Autoroll.—An electrically or manually operated filter combining high efficiency with low operating costs.

Full technical data available from the Sole Agents:

## THE LEINSTER ENGINEERING CO., LTD.

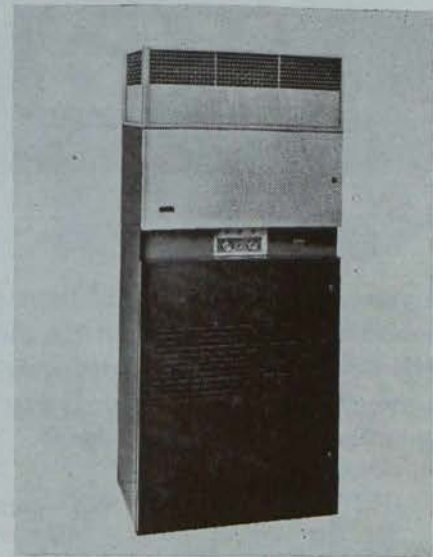
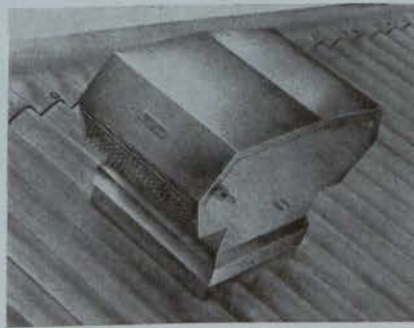
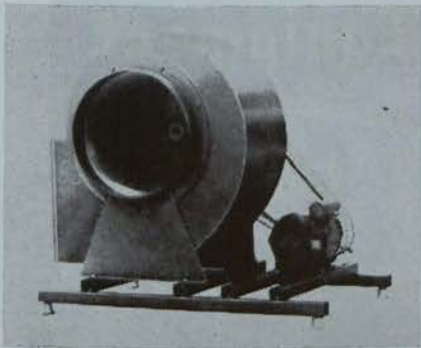

from page seventeen

range of patent roof extractors for powered ventilation of all types of industrial and commercial buildings. We show the "Mechavent" Roofline with high exhaust capacities for industrial application. This unit has hinged head and optional built-in automatic heat conservation shutters. Size range, 9" to 42". Capacities:

700 c.f.m. to 19,500 c.f.m. Aluminium or steel construction.

The Mechadome is a unique design for flat roofs, while other units on show include the Power Dome, Lowline and Mechavent fan units for varied applications, including kitchen, internal bathrooms, toilets, etc.

\* \* \*

Centrifugal fans to be exhibited by Standard & Pochin Bros. Ltd., of Leicester, have been selected from the company's extensive range of fan engineering equipment. Fans of standard design will be shown, also products built to individual requirements.

From the now extended range of

Seen here (from left) are: one of the improved Standard and Pochin Bros.' QP type of fan sets; the Greenwood Airvac Mechavent roofline processed extractor; and the new Tempair 5,000 air conditioning unit. (See Preview).

quiet running "Q.P." Fan Sets, a typical installation is shown, and full details are available. A recently de-  
Continued page twenty-one

# TYLOR Meters

## Liquid Control at Low Cost



● Tylors Model LL-3. Robust meter for oil-consumption in burners.

- ★ BLENDING AND BATCHING OF INDUSTRIAL LIQUIDS FOR AUTOMATIC OR MANUAL CONTROL.
- ★ REMOTE CONTROL OF COMPLETE PROCESSES FROM A CENTRAL POINT.
- ★ MEASURING OIL CONSUMPTION FOR BOILER HOUSE PLANT.
- ★ RATE OF FLOW INDICATION.
- ★ WATER METERS FOR ALL DUTIES.

# TYLORS



55 RATHGAR AVENUE, DUBLIN.  
'Phone: Dublin 904603. 'Grams: "Tyland," Dublin.

# Luwa Air Conditioning Equipment

30 years of experience, backed by intensive research have enabled LUWA to solve, effectively, current air conditioning problems. The units illustrated are those more generally in use—though there are many others built for particular applications in standard unit form.

1. The LUWAIR SK + SKT—compact units designed for free air discharge. Self-contained refrigeration units with water-cooled condenser.
2. LUWAIR S+SV—remote type unit air conditioners. For use with chilled and/or hot water. Many assembly variations from basic components. Horizontal, vertical or L-type arrangement.
3. LUWA INDUCTION UNITS—unit air conditioners for high-pressure induction type systems. Various types. Built-in air filter. Super quiet operation.
4. PACKAGED WATER CHILLERS WK—automatic operation with capacity control. Motor and compressor mounted in anti-vibration cradle. Low starting current at full torque of motor.
5. LUWETTE J + JM—small fan coil room air conditioners, with three-speed fans for super quiet night operation.

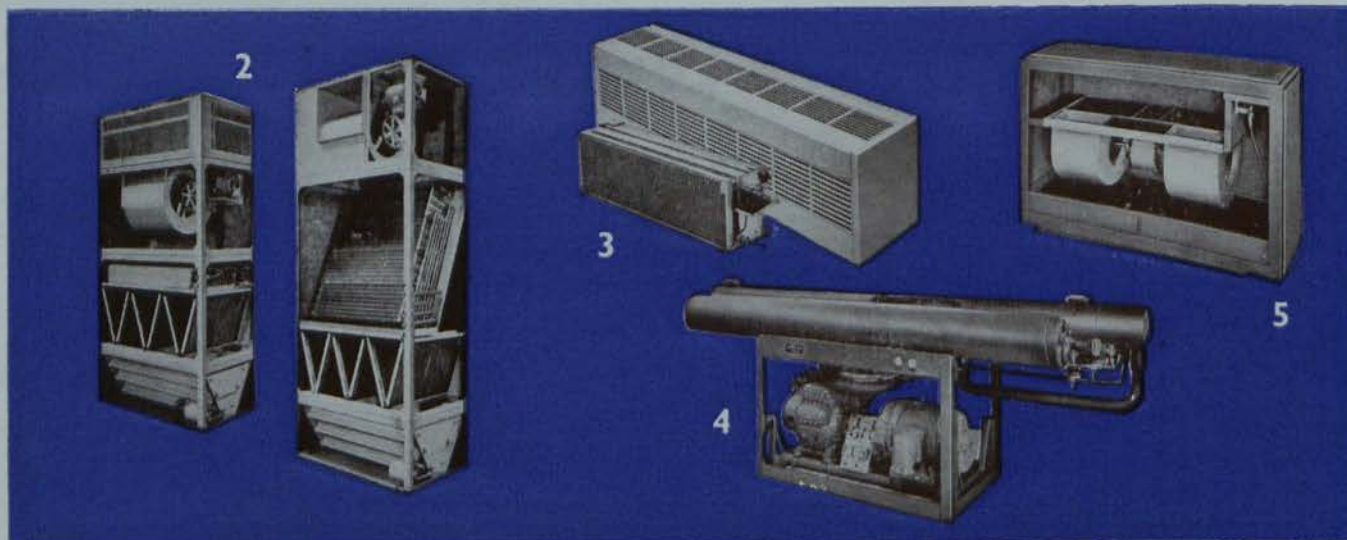
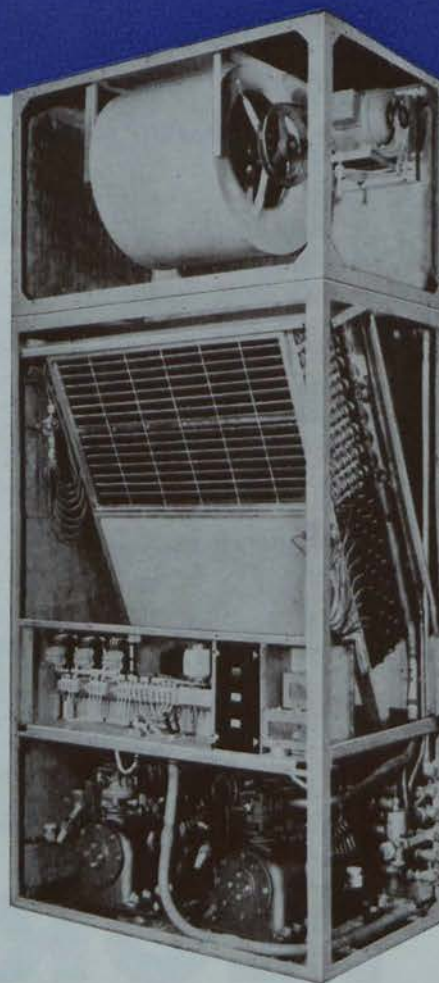

## Luwa (U.K.) LTD.,

340 Clapham Rd., London, S.W.9.

Tel: MA Cauley 0333

Visit us at STAND 115

### HEVAC 1964

Olympia, London

<https://arrow.tudublin.ie/bsn/vol3/iss12/1>

DOI: 10.21427/D7RX3G. Frankfurt, Paris, Barcelona, Vienna, Baarn (Holl), Sao Paulo (Brazil), Charlotte (U.S.A.), etc.



from page nineteen

veloped aerofoil bladed fan of high efficiency is exhibited for the first time.

Also displayed are examples of the company's Gilled tubing and air heating products, including Calorier unit heaters and Flatfin ducted air heaters, for use on steam and L.P.H.W.

\* \* \*

Shown for the first time at Olympia by **Clyde Fuel Systems** is a horizontal, fully automatic oil-fired air heater for ducted systems. Another newcomer to the exhibition is the Clyde Tasso cast iron sectional boiler for coke, oil or stoker firing.

\* \* \*

As well as a new range of small multivane fans, the **London Fan & Motor Company** introduce several new types of roof units, manufactured in rust-resistant galvanised steel and heavy duty glass fibre. The company manufactures its own totally enclosed motors which are sealed during assembly, reducing maintenance to a minimum.

\* \* \*

New at Olympia from **Tempair**—a member of the **Roots Group**—is the "Quality 5,000" commercial and industrial packaged central air conditioning plant.

\* \* \*

Starting as a sales organisation for their American parent company, **Trane Ltd.** is now producing heating and air conditioning equipment in Scotland. At Olympia they show a representative line of equipment that they intend to manufacture. Additionally, packaged air conditioning units, imported from America, are ex-

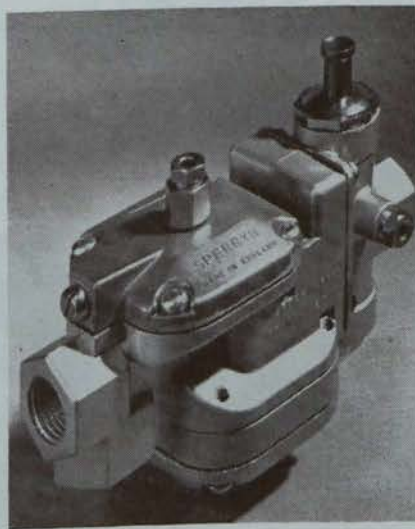

This is the new Sperry G880 Control (see Preview).

hibited. One example is a unit ventilator which is widely used in the United States for the air conditioning, heating and ventilation of school class rooms.

\* \* \*

A major design feature of **Trianco** is aimed at making their boilers, both industrial and domestic, trouble-free for cleaning and maintenance. Another feature is that all sizes—from 55,000 to 2,000,000 B.Th. units an hour, solid fuel or oil-fired, can be broken down into sections sufficiently small to pass through a 2' 6" doorway.

\* \* \*

The **Biddle** stand at the exhibition will occupy one of the three 2,000 sq. ft. areas, the largest in the exhibition. This stand will feature the products of both **F. H. Biddle Ltd.**, manufacturers of heating and air conditioning equipment, and their associate company, **Waterbury Ltd.**, manufacturers of warm air heating equipment.

A specially constructed acoustic chamber inside a 20 ft. tower will be used to demonstrate the operational quietness of the Noise Criteria tested Forceflo fan convectors. This chamber will be basically similar to that in which the Forceflos have been tested by the Acoustic Investigation and Research Organization. In addition, a number of different types and sizes of Forceflo, including the new miniature models, will be exhibited on other parts of the stand.

Five of the other exhibits will be shown publicly for the first time. Those are the new range of standardised coils, the new Torridaire space heater, the new Dehumidifier, the modified Universal unit heater and the Waterbury "G" series warm air heater.



THE MINISTER for Local Government is understood to be considering the making of special regulations which would enable Dublin Corporation to deal with the problem of air pollution in the city area.

**A CLEAN AIR SCHEME COMING?**

The City Manager, Mr. T. C. O'Mahony, said this at the Question Time session of this month's Corporation meeting.

He had been asked by Ald. Patrick Cummins, T.D., if any plans were under preparation to "combat the problem of air pollution in the city."

The Manager added that the new regulations would be made under the Local Government (Sanitary Services) Act, 1962. However, at present they had no power to deal with the problem.

\* \* \*

MR. G. H. C. CROMPTON, B.A.I., in a letter, states to the ENGINEER:—

**BIG CENTRE DESIGN COMPETITION**

"I publicised some weeks ago that I intend to offer money prizes for an architectural competition for a design for a Town Social Centre, open to young architects, engineers, and quantity surveyors, in the Republic of Ireland. I am not putting any age limit on the competitors.

"I would advocate that they should work in teams of three, one of each profession. The team's first prize will be £300, the second £200, and the third £100.

"I consider that the heart of the project should be a swimming pool which would be convertible into an assembly hall suitable for dances, theatricals, lectures or concerts. Around the pool should be at least six smaller rooms for games, reading, rehearsals, or other club activities; a restaurant-cafe-bar, with provision for caretaker-manager; half a dozen shops; and local conditions might call for further amenities. Lastly, there should be parking space for at least 100 cars."

Full details of the competition are available from the Hon. Secretary, Town Social Centre Design Competition, 20 Whitebeam Road, Dublin 14.



One of the Standardised Biddle coils to be introduced at HEVAC. This is a 24 in. x 24 in. x 2-row heating coil.



MEN IN THE BUSINESS KNOW

**boy  
| OF HARCOURT STREET  
| ans**

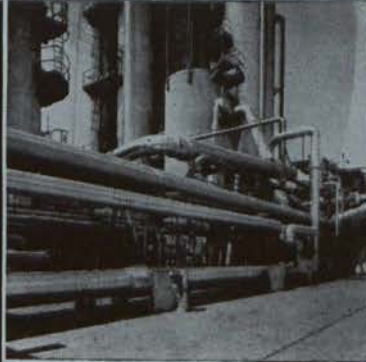

Boylans of Harcourt Street are sole agents for the insulation products of the Cape Asbestos Group of Companies.

The range of products includes: Rocksil and Rocksil-K rockwool materials, Caposite Asbestos Materials, Caposil HT and Caposil 1400 Calcium Silicate Materials, Asbestos Compositions, Rope Lagging and Cloth. Asbestolux. *Consult us with your insulation problems.*

**M. A. Boylan Ltd**

50a Harcourt Street · Dublin · Tel: 55408

A member of the Cape Asbestos Group of Companies

TW494

**T**HOUGH the design of cooling plants vary widely with different applications, they will always include three basic items of equipment. A compressor to maintain the circulation of the refrigerant, an evaporator or cooler to absorb heat from the medium to be cooled and a condenser to discard this heat at ambient temperature to an easily obtained coolant; water or air.

**Compressors.**—Of these three items, compressors are most uniform in design, consisting basically of two types: the reciprocating and the centrifugal. For commercial and industrial work I would say that over 90% of all refrigerating compressors are of the first type. A typical example of these is shown in Fig. 1. This is a twin cylinder, vertical in line machine. The number of cylinders varies from 1 to 6 with this arrangement. There is a limit to what can be practicably achieved with the in-line cylinder type, as for example 12 or even 8 cylinders means a very long and therefore expensive crankshaft, large cylinder block, and will need a large floor area in an engine room.

Modern multi-cylinder compressors have the cylinders grouped around the crankcase in V or W formation, as shown in Fig. 2. This allows 4, 6, 8 or 12 cylinders in a compact arrangement, using short crankshafts, small crankcases and occupying small floor area for a given capacity. Due to the smoother running characteristics of the V or W type machine, much higher speeds can be attained (over 2,000 r.p.m.) compared to an average upper limit of 900 r.p.m. for vertical in line compressors.

**R**EFRIGERATING compressors, usually driven by electric motor, can range in size from 1-12 h.p. to units absorbing several hundred h.p. per machine. For domestic cabinets, butchers' coldrooms, shop display, counters, etc., and on all sizes up to 5 h.p. it is now common practice to have the electric motor and compressor direct coupled and contained in the same housing.

In these sealed units, as they are called, the motor windings are cooled by the cold vapour returning from the evaporator. These machines represent a great saving in space and when produced in quantity are cheaper than the "open" com-

# MECHANICAL REFRIGERATION TO-DAY

PART 3:  
REFRIGERATING EQUIPMENT

pressor unit belt driven by an external motor for sizes up to 5 h.p.

Centrifugal compressors are usually employed on applications over 100 h.p. where only minor variations of compression ratio occur and where this ratio is of a low order—4:1. They are most useful as boosters for compound systems and for chilled water plants as used in air conditioning. The centrifugal compressor is similar in construction and design to a centrifugal pump. Where their use is justified they do have the following advantages over the reciprocating type:

With no rubbing parts such as valves, pistons, big and little end bearings, etc., high efficiency is maintained for the working life of the machine.

By

**DANIEL HEENEY**

An Applications Engineer with  
a leading Dublin specialist firm.

They have a small size for a given capacity; as the motion is pure rotation a smaller foundation can be used, and as the gas is delivered in a continuous stream, vibration is eliminated.

**Condensers**—The condenser is a refrigerating system, converts to liquid the high pressure gas delivered by the compressor, removing the heat of compression, and the latent heat of vapourisation and providing a continuous supply of liquid refrigerant for expansion in the cooler.

- Such condensers are of three types:
- (1) Shell and tube: water cooled.
  - (2) Induced draught evaporative: water cooled.
  - (3) Fully air cooled.

**T**HE shell and tube condenser usually consists of a welded steel shell with the water tubes inside this. The

gas from the compressor is delivered into the shell where it comes into contact with the tube bundle, through which water, preferably 60/70°, is circulating. The tubes are arranged in a number of passes so that the incoming and hence coldest water is in contact with the almost condensed vapour, and is then repassed up to 4 times so that on the final pass through it is in contact with the hottest gas straight out of the delivery pipe. This counterflow arrangement makes for greatest efficiency.

*Continued page twenty-five*

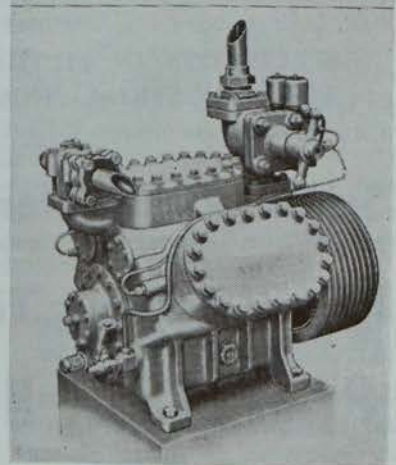
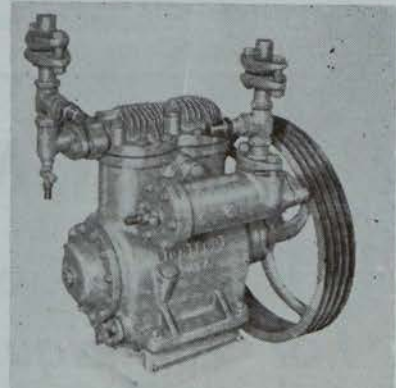

FIG. 1 and FIG. 2.

THE HEAT'S

**ON** . . . NOT IN

This is all-round heating. For any shape or size of vessel. For any type of heat demand. They're Isopanel—flexible electric panels tailored to suit the job. No overheating. No flow troubles. Loadings from 10-700 watts per sq. ft. Our thermostatic controls ensure minimum power consumption.

Installation and electrical connection is quick and simple. Send dimensions of tanks and temperature requirements.

We shall specify and quote by return, sending our 48-page illustrated catalogue.

# Isopanel

FLEXIBLE ELECTRIC HEATING PANELS

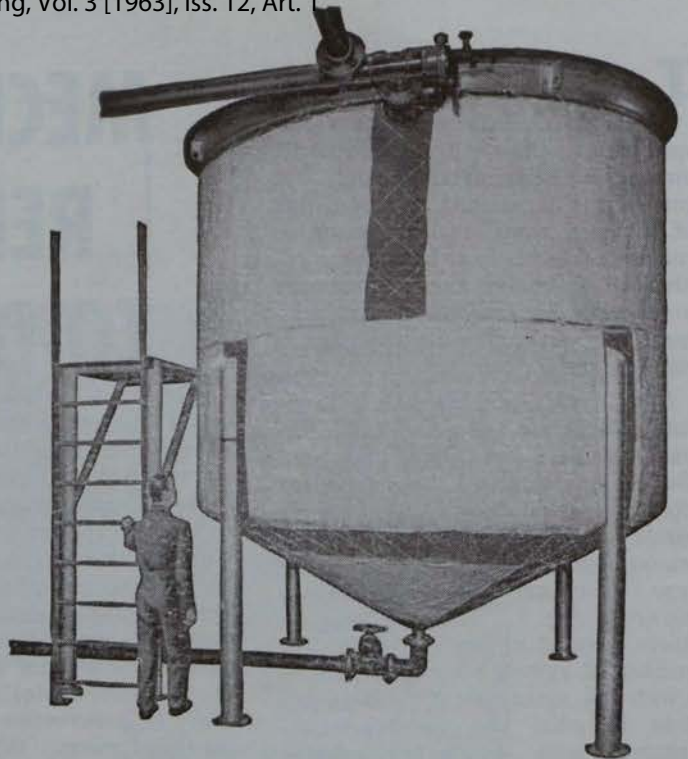

<b>ISOPAD PRODUCTS</b>	<b>ISOMANTLES</b> For flasks and process vessels 	<b>ISOTAPES</b> For pipes 	<b>ISODRUM HEATERS</b> For all standard drums 	<b>ISOPANELS</b> For any shape of surface 
------------------------	---	---	--	--

ISOPAD LIMITED • BOREHAM WOOD • HERTFORDSHIRE • TELEPHONE: ELSTREE 2817

1PT

# = SCHUMACHER =

## Porous Ceramic Filters For All Liquids And Gases

SPECIALISTS IN FILTRATION OF WATER SUPPLIES FOR INDUSTRIAL, HOSPITAL AND DOMESTIC USE

**Schumacher Filters** for removal of moisture, oil and impurities from compressed air systems.

**Porous Ceramic Tiles** for Aeration and Fluidisation.

# HALPIN & HAYWARD LTD.,

Unity Buildings,  
16/17 Lr. O'Connell St., Dublin, 1.  
Phone 48638.

Bedford Buildings,  
7 Bedford Street, Belfast.  
Phone 26343.

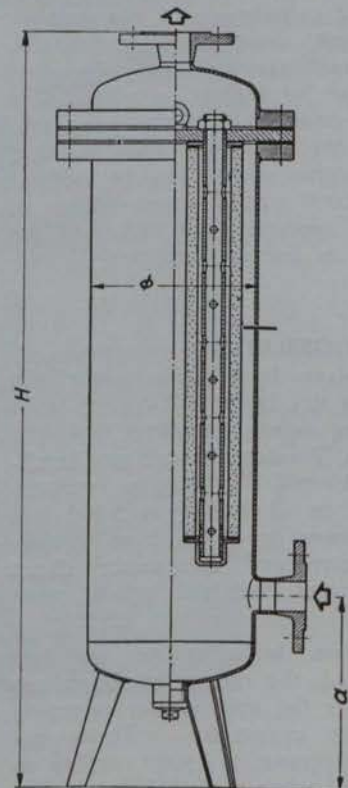

In a well designed and properly sized condenser the leaving temperature of the water will generally not be more than 15°F above the incoming temperature. Although very efficient and compact the shell and tube type require a constant supply of clean water which, if it is available, is often expensive in urban districts. Where such condensers are used it is often economic to instal an evaporative water recoler to work in conjunction with them.

The evaporative condenser is shown in Fig. 3.

**W**ATER is sprayed over the outside of the condensing coil, through which the gas from the compressor is circulated, and drips into the water tank at the bottom of the unit where a pump returns it to the sponge pipes. Air is drawn over the coils by the fan at the top and cools the wetted pipes by evaporation. Make up water is supplied through a float valve to maintain a constant level in the collecting tank. The eliminators shown above the spray nozzles prevent loss of water which might otherwise be carried over by the rapid air flow.

There is no upper limit to the size of these condensers but their first cost is usually only justified on plants over 5 tons capacity. Water consumption for a well designed unit is approximately 1.7 gallons per hour per ton refrigeration. Their immediate advantages are apparent in saving of water, coupled with the ability to maintain low condensing temperatures and pressures as the condensing temperature depends on the wet bulb temperature of the atmosphere where they are located. They are therefore the best condensers for hot dry climates where water is in short supply.

**T**HE fully air cooled condenser is best described by comparing it to the heating battery of a ducted air heating system. They consist of a bundle of copper tubes with copper or aluminium fins, housed in a galvanised steel casing. They are fitted with propellor or centrifugal fans to pass a large volume of air over the finned surface. The refrigerant circulates in the tubes and is sufficiently cooled by the air flow for condensation to occur. Their great advantage is, of course, that there need not be a water supply on a site where they are to be used, and they are free from the sealing and freezing troubles as-

# Refrigeration

from page twenty-three

sociated with the shell and tube, and evaporative condensers.

The shell and tube and evaporative condensers can be employed with any of the three common refrigerants. The fully air cooled units are not normally used for ammonia plants because of the higher condensing temperatures experienced with this type of condensor, but to the large user of Freon plant the air cooled type are more acceptable because of their trouble free operation under summer and winter conditions.

In next month's article I will describe some of the cooling systems in general use with a brief summary of the type of control systems employed for refrigeration plant.

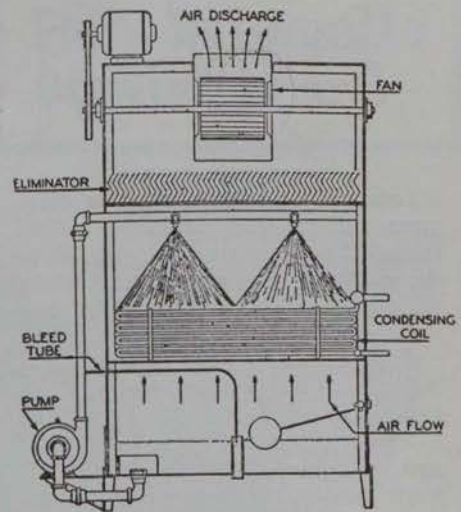

FIG. 3—Evaporative condenser.



A NEW addition to the already well-known range of Dravo gas fired industrial space heaters is announced by Powell Duffryn Heating Limited, of Camberley.

## ADDITION TO THE DRAVO RANGE

Manufactured by Coventry Radiator and Presswork Company Limited and marketed by Powell Duffryn Heating, the new unit is available in three models giving 65,000, 100,000 and 130,000 B.t.u./hr., and is complimentary to the established range of Dravo heaters which give from 300,000 to 1,500,000 B.t.u./hr.

Ideal for factory floors, stores, workshops, shops, warehouses, restaurants, offices, schools, garages and public halls, the new Dravo can be easily suspended from ceilings and roofs to avoid the use of valuable floor space.

Situated over gangways, open entrances and exposed walls, they can provide "booster" heat to eliminate cold spots. The new Dravo has four main features: It incorporates stainless steel heat exchangers; it has four-way air distribution louvres; the unit is



The new addition to the Dravo range.

fitted with a vitreous enamel draught hood; and it is all-welded.

The heat exchangers are constructed of all-welded 18 gauge stainless steel. The burners use neat gas and are fired directly into tubes. The combination of vertical and horizontal louvres deflect air sideways as well as down, giving even distribution of air to any area within 25 feet.

## NEXT MONTH

Because of the extended preview of the HEVAC Exhibition, our Special Survey on calorifiers and cylinders, pressure-vessels and tanks, has been held over until next month. —Editor.

Twenty-five

# Solders and Soldering

from page twelve

it forms a protective coating on these parts and prevents further oxidation whilst the parts are being heated to the soldering temperature, and whilst the molten solder flows onto the joint areas and "tins" them.

**Composition of Soldering Fluxes.**—Soldering fluxes can be divided into two main classes. The first, the active fluxes, are usually based on zinc and ammonium chlorides. They will work readily on brass, copper, lead and steel. However, zinc chloride has the property of being hygroscopic. That is, it absorbs water from the surrounding atmosphere and the flux residue remaining after soldering becomes wet. This wet flux residue will cause corrosion of the soldered parts, if it is allowed to remain on the finished joint.

It is, therefore, imperative to remove the flux residue after soldering by washing in hot water or in extreme cases by using an acidic wash (e.g., cold 1% hydrochloric acid in water, or hot 5% Citric acid in water). In some cases a wipe with a cloth is sufficient to remove the flux residue.

The second class of fluxes is known as the safety or non-corrosive fluxes. They are used in conditions where it is impossible to remove the flux residue after soldering, as, for example, in radio, television and other intricate electrical work. These fluxes are based on resin which becomes active enough at the soldering temperature to remove the oxide film from the metal parts to be joined, but on cooling down becomes a hard, dry residue which is completely inactive and will cause no corrosion.

**FLUXES Used In Plumbing.**—The tallow used as a flux by plumbers when making wiped joints does not fall into either of the above classifications. It is not as active as the active fluxes and does not cause corrosion when left on a joint after soldering. However, it is not a true safety flux either, since the residue stays soft and does not become hard like the residue of a resin-based flux.

The flux used for making joints in capillary fittings is usually of the active type and after soldering the residue is removed by wiping with a damp cloth.

Table II—MELTING TEMPERATURES AND USES OF SOME GRADES OF PLUMBERS' SOLDER

Grade	Solidus		Liquidus		Uses
	°C	°F	°C	°F	
Belfry	185	365	254	490	For all general plumbing.
Abbey	185	365	247	478	For high grade plumbing and cable jointing.
Prior	185	365	245	473	Special high-tin content alloy for cable jointing.



**NOW, STORAGE HEATER FROM PD**

Powell Duffryn Thermal Storage Heater recently announced.

The lowest priced unit is designed specifically to take full advantage of the times when electricity is available at special, low, off-peak rates.

Designed with clean, simple lines which, with the pleasing two-tone grey finish, blends attractively with both traditional and modern decoration, the Thermal Storage unit requires very little space, being less than twelve inches in depth. It has a 3 Kw. rating.

Installation is simple as the elegant case and the high density refractory bricks are delivered separately. A special input charge controller enables the householder to regulate the amount of charge according to the weather.

**WILL CUT INSULATION COSTS**  
 NOW ON the market here is Foamflex, a new and improved pipe insulation material for hot and cold working and low pressure steam. Its thermal conductivity

(0.22 B.t.u./inch/sq. ft./hour/F. @ 70F. (21 C.) is extremely low. It is light in weight, durable, and unusually flexible. It cuts down installation costs and is available in a wide range of sizes.

Made of Polyurethane foam, Foamflex comes in 9ft. 9in. lengths. The sections are slit longitudinally down the side and are simply slipped over the pipe. The join is then sealed, either with Foamflex waterproof adhesive tape, Foamflex adhesive or any contact type adhesive. The end joints are sealed in the same way.

Its flexibility allows Foamflex to be carried round slow bends with ease and it is easily cut or mitred to fit bends with sharp internal radii, "T" junctions, etc. Its resilience also reduces to a minimum the risk of damage in transit, on site, or after installation.

This new material is manufactured by Dunlop Semtex Limited, the flooring division of the Dunlop Group, who pioneered thermoplastic floor coverings in Britain. To-day, the company is one of the world's largest producers of plastic tiles and floor coverings.

Foamflex is distributed in Ireland by British Steam Specialties Limited.

\* \* \*

**POWELL DUFFRYN** Tayco solid fuel boilers, manufactured by Powell Duffryn Heating Limited, of Camberley, Surrey, are now to be sold in only two standard colours—white and cream.

A third colour, Moonstone Blue, will be available at an additional cost of 5 per cent.

**24 BRANCHES THROUGHOUT THE U.K. AND EIRE**

**CLYDE**

**Fully Automatic Oil Burners**

**HEAVY OIL**

Suitable for 200/950 seconds fuel oil, these burners can be supplied for on/off or high/low flame working. All high/low burners are supplied with "COMPOSITE" combustion heads to give high combustion efficiencies with maximum turn down ratios.

**LIGHT OIL**

Complete with photocell flame failure control, thermostat and control box, these burners are silent running and are suitable for light gas or diesel oil.

- \* Fully Automatic
- \* Thermostatically Controlled
- \* Electronic Controls
- \* Easy to install and maintain
- \* Suitable for Light Diesel or Heavy Fuel Oils

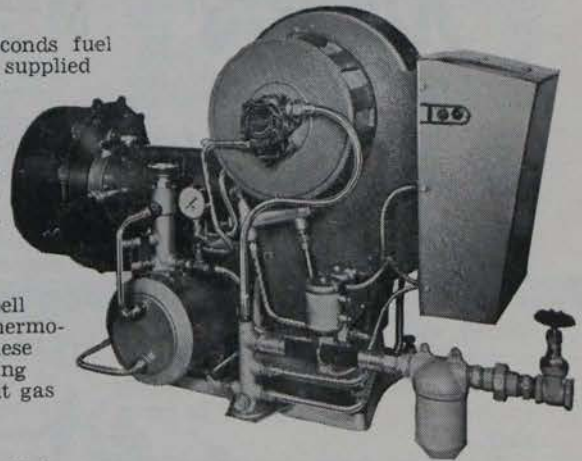

**SEE US ON STAND 267**

at the International Heating, Ventilating and Air Conditioning Exhibition  
Olympia, London, 15th-24th April, 1964.

Write for further details to:—

**CLYDE FUEL SYSTEMS LTD.**

80 Holywood Road, Belfast. Tel.: Belfast 65365/6.  
Branch at Londonderry.

**CLYDE FUEL SYSTEMS (IRELAND) LTD.**

6 Mount Crescent, Dublin. Tel.: Dublin 66489.  
Branches at Cork and Limerick.



**418 PATTERN RATCHET DIESTOCK**

Better threads, easier cutting, and quick and simple die and guide changing are the attractive features of this Chatwin product. The 418 Pattern Ratchet Diestock and die must satisfy the need for a tool which makes pipe thread cutting economical. Dies are available for the standard range of B.S.P. threads and alternatively, to Whitworth, U.S. standard, and Unified, within capacity of stock.



*Ample Strength for the TOUGHEST JOB*



**STILLSON PATTERN PIPE WRENCHES**

Heat treatment of the handle and jaw gives correct degree of hardness and prevents bending and breakages. Sturdy, light in weight and easy to handle, these wrenches are guaranteed against defects in material and workmanship.

**THOS. CHATWIN & CO.**

Victoria Works, Great Tindal Street, Birmingham, 16  
Telephone: Edgbaston 3521-3

The Irish Plumbing and Heating Engineer.

# trade Topics

B.S.A. HARFORD Pumps Limited have increased their range of central heating equipment

**PANEL RADS FROM B.S.A. HARFORD** to include a complete range of steel panel radiators.

The radiators are offered with bosses sited in the conventional positions, one at each end at the bottom of the radiator and one at the top. The radiator is reversible.

The pricing system for the radiators is in line with the modern approach of a flat charge per square foot of heating surface plus a standard charge per radiator, thus simplifying the quick pricing of the radiator content of an installation. The prices include the necessary fixing brackets.

The range includes single, double or triple panel radiators, shelves and clip-on towel rails. The radiators are made from 18 gauge mild steel and supplied painted with a non-metallic primer. They are tested to 100lbs.-sq. in. and have a water content of approximately 0.83lb. per sq. foot of heating surface. The weight per sq. ft. of heating surface is approximately 2lb.

This expansion of the B.S.A. Harford range of products now means that they supply all the main components for an oil-fired central heating installation. An attractive full colour eight-page leaflet giving full details of this new range of radiators is now available on request to B.S.A. Harford Pumps Ltd., Northside House, Mount Pleasant, Cockfosters, Barnet, Herts.

\* \* \*

WHITE - RODGERS Limited of Markham, Ontario, Canada, have announced the formation of their United Kingdom Branch at 75, South Western Road, Twickenham, Middlesex. An official said that the appointment of distributors here was under negotiation at present.

**A NEW BRANCH FORMED**

White-Rodgers Limited manufacturing heating, ventilation and air conditioning and major home appliances.

White-Rodgers Limited manufacturing heating, ventilation and air conditioning and major home appliances.

## NOW PLUMBERS USE DIAMOND DRILL RIGS

**M**ANY plumbers in America are equipping themselves with natural diamond drill rigs. Small natural diamond-tipped drill bits are simplifying for them the job of boring holes in masonry walls or foundations for installation of new pipes.

These bits go through brick, stone, concrete, tile and cinder block with a smooth, fast cutting action that is almost noiseless.

They are available in a wide range of sizes, from a 1/4-inch up to 14 inches in diameter, permitting the choice of a bit of just the right size for the pipe to be installed. No dust or debris is created by the natural diamond bits, and they do not break surrounding material as do old-fashioned impact methods. There is therefore no making-good required.

The diamonds are water-cooled while the drill is cutting through masonry materials; vacuum units catch the water and remove it to a container.



The bits are available at short notice from F. York and Partners Limited, Lascelle Street, London, S.E. 10, or John Place Limited, 79 Wellington Street, Ballymena. "May be able to supply these bits," said a spokesman for the Industrial Diamond Bureau in London.

refrigeration air conditioning and major home appliances.

Heating controls, which historically represent the major portion of White-Rodgers' business, have been expanded gradually over the past twenty-five years to a full range of control equipment in each of the three domestic automatic heat fields—oil, gas and electricity, where a reputation has been achieved as world leaders for dependable quality controls with an outstanding aesthetic appeal.

An example of new product introduction in the heating control field is the White-Rodgers line of moderately priced zone control equipment which has been received enthusiastically in both Canada and the U.S.



Shown here is one of the new White-Rodgers D'Lux low voltage room thermostats.

Mr. R. W. Jelbart, T.D., M.Inst. M.S.M., has been appointed Sales Manager of the new branch.

\* \* \*

A NEW standard weatherproof casing for their complete range of 2 1/2-in. diameter instruments has been introduced by

**CASINGS WILL BEAT WEATHER**

The British Rototherm Co. Ltd. Previously a number of different case patterns were in use for the various instruments. To achieve uniformity a standard pattern has now been designed for all types and fittings.

The new case, which is fume and weatherproof, is an aluminium casting of considerable strength and rigidity. The metal bezel, with polished chromium plate finish, is screwed to the body and tightened down on to gaskets to give a completely weatherproof seal, bringing the 2 1/2-in. models into line with the company's larger instruments.

Irish agents: Rototherm Precision & Instrument Co. Ltd., Beechwood Works, Killiney, Co. Dublin.

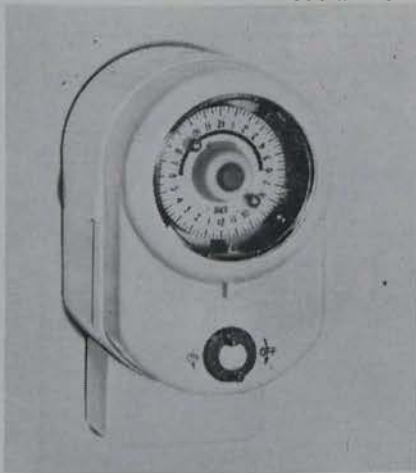

## New design for Vennerette

A new design of the Vennerette domestic time switch, the Mark II., has been introduced by Venner Limited. Up-rated to 30-amperes and employing a four-way terminal block to enable the clock to be separately connected, the switch is particularly designed for controlling electric space heating, immersion heaters, oil or gas-fired boilers, porch and driveway lighting or greenhouse heating, and provides two "On-Off" switching periods on the 24-hour dial.

The Vennerette Mark II., measuring only 5, 3/8" x 3" x 3" (projection), is finished in an ivory shade to match all colour schemes, and employs the "Easiset" dial, a feature of which is the absence of screws or pins needing manipulation. It is the most compact 30-amp time switch so far marketed.

A manual control, enables the circuit to be switched on or off without affecting the normal dial operation. Alternative versions with day omission device, or with solar dial for automatic sunrise and sunset switching, are available. Irish agents: Roper Bros. Ltd.

CAPE INSULATION and Asbestos Products Ltd., of 114, Park Street, London, W.1, have

introduced "Rocksil Attic Insulation" a special super grade of attic insul-

ation material intended for use in centrally heated houses. Supplied in roll form and easily handled and laid, the material has no fire risk, will not support vermin or fungus, will remain in position and not deteriorate.

The ends should be joined at the eaves and when unrolled the material will lie snugly between eaves. It is available in rolls 25 ft. long and 16 in wide, which will give coverage of 200 sq. ft. in six rolls or 1,000 sq. ft. in 30 rolls. Price: 18s. 9d. per roll. Irish agents: M. A. Boylan Ltd.

\* \* \*

THE SIGMUND Pulsometer cellar drainer is a completely automatic centrifugal pump for removing water from basements and other places liable to flooding. The vertically mounted motor is controlled by float gear and the unit will auto-



matically lower the depth of water above the floor from as much as 2ft. 6in. to about 4 in. Depressing the float by hand allows the water level to be further lowered to about 1 inch. Performance envelope ranges from 1000 gal./hr. against 3 ft. head to 250 gal./hr. against 18 ft.

## THE THIRD INTERNATIONAL



# HEATING VENTILATING AND AIR CONDITIONING EXHIBITION



OLYMPIA · LONDON  
15-24 APRIL 1964

Two hundred and fifty firms from 10 countries, occupying an area of 200,000 square feet, will be showing all aspects of domestic and industrial heating, ventilating and air conditioning, including air handling and treatment, dust and fume collection, mechanical draught, process heating, refrigeration, and all allied and ancillary processes and equipment.

Times: 10 a.m.—6 p.m. daily, except Sunday. Close at 4 p.m. on final day. Late Evenings: Open until 9 p.m. on Thursdays, 16th and 23rd April. Admission: 3/6, or by ticket obtainable only from exhibitors. Overseas visitors free.

An IEE Exhibition

INDUSTRIAL EXHIBITIONS LIMITED 9 ARGYLL STREET LONDON W1



# SO I SAID—

# JOSAM

Yes, you see he wanted to know if there was a really comprehensive range of drain fittings available on the European market, so naturally I said "JOSAM." "JOSAM," I said, "they've got the lot—floor drains, anti-flooding valves, roof drains, oil and grease interceptors, shock absorbers—the lot. Take a look at this roof outlet," I said, showing him this advert. "The very thing!" he said. "JOSAM, is it?" "JOSAM it is," said I. So off he went to Dockrells to have a look at the rest of the range. Yes, that's right, Dockrells of Georges St. Oh, don't mention it—you're welcome!



## THOS. DOCKRELL, Sons & Co. Ltd.

South Great Georges St., Dublin, 2. Phone 76871.

SOLE DISTRIBUTORS FOR REPUBLIC OF IRELAND.

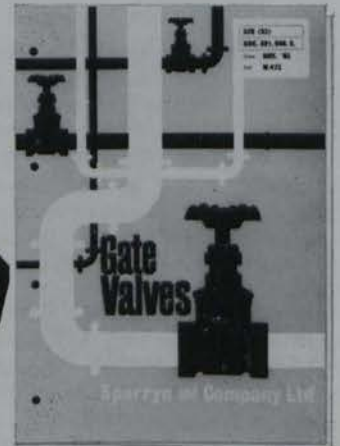

A comprehensive range of Sperryn Gate Valves from 1/2" to 4" B.S.P. are fully described in a new brochure recently released to the trade. If you have not received a copy, drop us a postcard today.

Brochure Ref. 473

SPERRYN & COMPANY LIMITED, Moorsom Street, Birmingham, 6.

Telephone: ASTON 4011  
(6 lines). Telex: 33724.

Agent for the Republic of Ireland: C. B. Sheridan, 10 Herbert Place, Dublin, 2. Tel.: 66283.



# SPECIAL REVIEW

**THIS MONTH**  
ROOFING MATERIALS

## ROOFS: EARLY DESIGN CONSIDERATION A MUST

**T**HE aesthetic qualities of a roof are important and due consideration is necessary at an early design stage if unhappy results are to be avoided.

A proposed new building for a mature neighbourhood should reasonably conform as far as materials and style are concerned, otherwise the new roof will stick out like a sore thumb; indeed its erection might be banned by Town Planning Acts or other similar prescriptions.

In new housing developments where innovations would not be in offensive contrast with traditional styles, one may find mono-pitch roofs, or flat roofs in place of the older commonly double pitched ones.

The all important functional properties of a roof will include such things as durability; water tightness; resistance to wind loadings and, in some places, to snow loads; of adequate internal insulation; fire resistant, and so laid on as to avoid or minimise the need of maintenance services.

**Mono-pitched roofs** may be craftsman covered with aluminium or copper strips. These materials are supplied in convenient rolls, usually 2ft. wide, since this lends itself to well tried traditional roofing techniques.

The so-called "traditional" working techniques for these plumbers' hard-metals include: dog-eared corners, welted breaks, batten rolls, and standing seams.

**A**LL of these are easily executed by the plumber already skilled in lead sheeting working to flats, dormers, etc.

Free publications obtainable from the British Aluminium Company, Norfolk House, St. James Square, London, W.1, and from the Copper

Audley Street, London, W.1, will show practical, simple, and effective methods, specially developed for use by the competent plumber.

**Zinc** is another possible alternative material suitable for flat, mono-pitched or even double pitched roofs, as also are aluminium and copper strips. The durability of zinc is sometimes questioned but, in clean atmospheres, it can be shown to have quite a long life.

The roll-cap technique, developed over 60 years ago, is still used in zinc roofworks—it cannot be improved upon—but in certain applications, and using soft temper zinc sheets, standing seam techniques can be used. Further information is freely obtainable from the Zinc Development Association at 34 Berkeley Square, London, W.1.

**LEAD-SHEET**, the traditional material of the trade, must, of course, receive mention in any survey of roofing materials. Its durability is well known. Its weight and low mechanical strengths require compensatory roof design considerations which sometimes restrict its use to flat roofs or weathering details to slated or tiled roofs. However, the sensible use of modern lead-burning methods can speed the laying of large areas of lead, and can be used to pre-fabricate weathering details at a fraction of the cost of the older on-site bossing methods.

A free booklet, "Practical Notes On Leadburning for Plumbers," is obtainable from the Lead Development Association, 34 Berkeley Square, London, W.1, and leadburning will be fully dealt with in A. L. Townsend's four-stage course on Plumbing in a later edition of this Journal.

**Non-traditional techniques** of roofing domestic and industrial buildings

include many patent sheeted systems. The Northern Aluminium Company, at Banbury, Oxfordshire, produce the well known "Noval" cladding and roofing of the interlocking edge kind.

The British Aluminium Company recently devised another interlocking roof form called "Lock-Roll"—an inexpensive and quickly applied roofing system particularly suited to domestic roofs.

**For industrial buildings** subject to corrosive atmospheres or processes, the United Roofing Companies Ltd., Uralite House, Whitehall Place, Gravesend, Kent, produce the long lasting "Cellactite"—a steel covered corrugated sheet enveloped in asphalt bonded asbestos protective material.

This firm has also developed a patent form of prefabricated roof decking for industrial buildings.

"**Nuralite**" is yet another product of this company and was specially developed for use by plumbers as an alternative to metal roof coverings.

The material is supplied in light, conveniently handled sheets of asphalt bonded, flexible thermo pliable material of high durability. "Nuralite" is easily and conveniently worked by craftsmen plumbers and offers considerable economy in laying and is backed by a 25-year guarantee.

"**NURALITE**" is recognised as a plumbers roofing material and forward looking plumbers will have, or write for, the informative booklet, which is free and explains the simple methods by which this new roofing material is laid and jointed in all situations likely to be met with in domestic and industrial applications. **Gutters, Downpipes or RWP's** are obtainable in a wide variety of materials and patterns. Choice will be affected by such things as fitted ap-

*Continued overleaf*

**IN this equipment review  
we take a look at new  
developments in the fields  
covered by the foregoing  
special review. (All claims are  
those of the manufacturers).**

THE JOSAM series 300-59AD has been designed with a view to the problem relative to drainage from P.V.C. or rubber types of floor cover-

ing. The grating and clamping device are integral and have a vertical threaded adjustment from the actual drain body of from 2" minimum to 2 3/4" maximum, enabling variation in floor level to be met within limits.

The body service of the Series 300-59AD is in leagured cast iron and available in 2", 3", and 4" outlet sizes with three alternative outlet connections. The adjustable gratings and clamping device are available in polished bronze and polished nickalloy as required.

Josam "Levelless" floor drains meet the problem of changes and costly

labour involved when floor levels or drain connection levels are adjusted and/or floor finishes are renewed. With the Josam, "Levelless" floor drain, the grating is removed, the locking set screw is undone, then the grate is raised or levelled on its rolled thread to meet the new level requirements.

The manufacturers are Josam Products (UK) Ltd., The Yews, Old Road East, Gravesend, Kent. Information on the complete range of Josam *PRODUCT REVIEW continued page thirty-four.*

# PIPE WATER

*Where and When*

*You Want It!*

WITH—

- **Low Density Polythene Tubing** to B.S.S. 1972.
- **High Density Polythene Tubing** to B.S.S. 3284 Table 1.
- **P.V.C. Tubing Service Pipes** up to 2" Class "C"
- **P.V.C. Mains** in sizes 2"/3"/4".

Manufactured by:

***O'Brien Plastics Limited,***

Bishopstown, Cork. Telephone No. 41834/5.

STOCKED BY ALL LEADING HARDWARE MERCHANTS



This special Review article was compiled by A. L. Townsend.

*from previous page*

pearance in relation to the materials of construction and the style of the building; durability, water carrying capacity, and freedom from maintenance troubles.

So far as durability is concerned, cast-iron will need frequent and conscientious periodic painting maintenance, unless it is vitreous enamelled. Electrolytic corrosion likelihood must be considered in relation to heating materials of other kinds when zinc, galvanised mild steel, aluminium or copper gutters are proposed.

Plastics materials for eaves gutters and RWP's are fast becoming a popular choice and many firms are producing these in P.V.C., a chemically inert, corrosion free material. Readers would do well to obtain trade literature, as advertised in this Journal, so as to be really up-to-date in this matter of domestic roofwork drainage equipment.

Gutter and RWP sizing is an important factor in roof drainage, and one on which little or no useful information is generally available.

Domestic roof drainage sizing is often simple and sufficiently explained in most manufacturers' illustrated literature, but industrial roof drainage design is quite another matter.

The Institute of Plumbing at 81 Gower St., London, W.C.1, has published a really practical and informative paper entitled "The Sizing of Roof Outlets, Gutter Nozzles, and Rain Water Pipes," by H. A. Howick, M.I.P.H.E., M.I.P., and copies of this may be obtained at 2/- each.

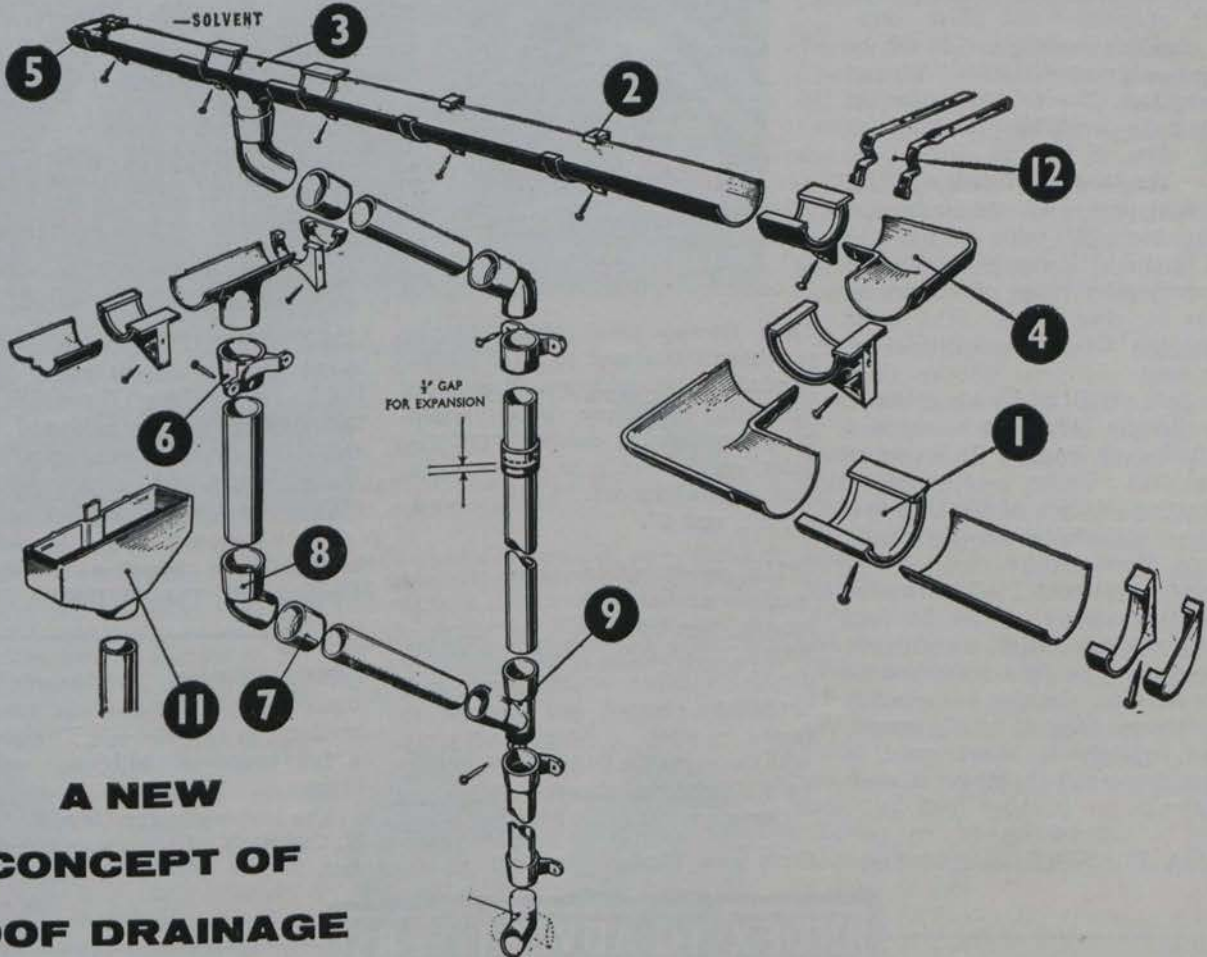

**A NEW  
CONCEPT OF  
ROOF DRAINAGE  
WITH ONLY TWELVE P.V.C COMPONENTS**

Terrain roof drainage represents the systematic approach. Ten basic units in the Terrain Range have been designed to take the best advantage of the particular characteristics of P.V.C.—rather than to produce copies of standard units—and to combine maximum efficiency with ease of erection.

ALSO **TERRAIN P.V.C. SOIL AND WASTE SYSTEM**

**TERRAIN P.V.C. VENTILATION SYSTEM**



\* Please avail of our advisory service

Terrain Systems are based on the use of unmodified, unplasticised P.V.C.

**UNIDARE LIMITED**

FINGLAS, DUBLIN 11

'Phone 71801 (13 lines)

Thirty-three

# PRODUCT REVIEW

from page thirty-two

ducts may be obtained from the Irish distributors, Thomas Dockrell, Sons & Co. Ltd., South Gt. George's St., Dublin.

\* \* \*

UNILUX translucent glass fibre reinforced sheeting is available in a range of profiles to match asbestos cement, aluminium and other corrugated cladding materials. It can be supplied as a normal (Grade "A") and fire retardant (Grade "FR") sheeting.

Unilux is available in insulated double skin, as well as single skin, form. The insulated sheeting gives a U value of 0.54, while the single skin sheeting has a U value of 1.12 (A) and 1.11 (FR). It can be supplied in a comprehensive range of colours as well as in clear form. The clear sheeting has a light transmittance of 85 per cent.

The light weight of Unilux makes it easy to handle and it can be supplied in virtually any length. It is easy to cut and drill. Unilux is marketed by the Sheeting Division of the Universal Asbestos Manufacturing Co. Ltd., Watford, Hertfordshire.

Aspect translucent PVC corrugated sheeting is perfectly suitable for roof cladding where good light transmission is required. The light transmittance of Aspect clear sheeting has recently been increased from 82 to 90 per cent. without any adverse effect upon its weather flame and shatter-proof characteristics.

\* \* \*

OSMA PLASTICS Ltd., of Rigby



Lane, Dawley Road, Hayes, Middlesex, have introduced to their building products range the Osma Plastics soil, ventilating and waste goods system. It is based on the accepted "O" Ring joint, and is made to metric sizes. Inch equivalents are: 1 1/4", 1 1/2", 2", 3", 4", 5", and 6".

The comprehensive range of pipe-work is available in 6', 8', and 10' lengths, together with a full range of fittings, including bends, branches, double branches, access pipes, W.C. connectors, bosses, and can be obtained ex-stock. Primary advantage with the system is that being in P.V.C., painting and maintenance are omitted.

Osma are also introducing an entirely new Waste system in plastics

ILLUSTRATED here is a section of a recently constructed house in Co. Dublin showing the "Terrain" P.V.C. rainwater system and soil and waste system in natural colour grey. The Terrain systems are also available in colours Black and Stone.

The "Terrain" system is marketed by the Water Supplies Division of Unidare Ltd., Finglas, Dublin.

made from A.B.S. (Acrylonitrile Butadiene Styrene). The Waste system is available in 1 1/4", 1 1/2", and 2" sizes with a full range of injection moulded fittings.

The Irish agent for Osma is Mr. V. H. Campbell, 11 University Road, Belfast.

## INDEX TO ADVERTISERS

Airnesco Products Limited .. .. .	17	Luwa (U.K.) Limited .. .. .	20
Biddle, F. H., Ltd. ... .. .	15	McMullans Kosangas Limited ... .. .	10
Boylan, M. A., Limited .. .. .	22	Mono Pumps Limited .. .. .	Cover iii
British Steam Specialties Limited .. .. .	Cover i	Monsell Mitchell & Co., Limited .. .. .	Cover iii
Bullfinch (Gas Equipment) Limited .. .. .	35	Morley, G. F., Limited .. .. .	1
Chatwin, Thomas & Co. Limited .. .. .	27	Newman Hender & Co., Limited... .. .	18
Clyde Fuel Systems Limited .. .. .	27	O'Brien Plastics Limited .. .. .	32
Crowe, W. & L., Limited .. .. .	7	Rennert & Co. G.M.B.H. .. .. .	1
Dockrell, Thos., Sons & Co., Limited .. .. .	30	Sanbra Fyffe Limited .. .. .	7
Du Bois Co. Limited, The, .. .. .	1	Special Notice (Box I.P.H. 28) .. .. .	36
Evode Industries Limited .. .. .	Cover iv	Sperryn & Co., Ltd. ... .. .	30
Halpin & Hayward Limited .. .. .	24	Tylors of Ireland Limited .. .. .	19
Industrial Exhibitions Limited .. .. .	29	Unidare Limited .. .. .	33
Isopad Limited ... .. .	24	Wavin Pipes Limited .. .. .	Cover ii
Leinster Engineering Co. Limited .. .. .	18	Willis, Wm., & Co., Limited .. .. .	36

Circulation embraces: (i) Plumbing and Domestic Heating—Plumbing Contractors, Heating Contractors and Installers, Electrical Contractors, Builders' Providers and Merchants, Manufacturers, Agents, Representatives and Distributors of fittings and equipment to the trades; (ii) Industrial Heating, Air Conditioning and Ventilating—Architects, Consulting Engineers, Corporation and Co. Council Engineers, Heating and Plant Engineers, Building Contractors, Ventilation Engineers.

# 1,200 plumbers get pay increase

**TWELVE** hundred plumbers in the North have got another pay increase of a halfpenny an hour. The increase brings the basic rate for journeymen up to 6s. 3½d. per hour. The men are benefitting from an award of the National Joint Council

for the Building Industry under the cost of living index.

The award was announced at the annual general meeting of the Northern Ireland Master Plumbers' Association in Belfast last month.

At the meeting Mr. J. A. Willis (Willis Heating and Plumbing) was elected President in succession to Mr. W. B. Jefferson (William Coates and Co.).

Other officers elected were:—Vice-presidents, Mr. R. J. Brennan (Wm. Brennan and Sons), Mr. J. B. Johnston (J. Johnston and Sons, Dungannon);

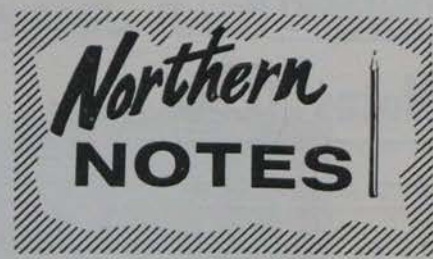

Treasurer, Alderman W. J. Lawther; Committee, Messrs. W. B. Jefferson, M. H. W. Joyce, W. N. Allen, J. Cumming, F. Watson and M. Stevenson.

The employers' representatives to the Joint Council for the Plumbing Industry (N.I.) were Messrs. Willis, Cumming, Brennan, Allen, and J. Magilton.

\* \* \*

**SHORT BROTHERS & Harland Ltd.** have ordered what are believed to be the largest shell boilers built in the United Kingdom for space heating in their Queen's Island aircraft works.

The order—understood to be worth £50,000—has been placed with Richardson's Westgarth Group for their Sunderland works. It is for three "Maxecon" wet back shell boilers, each to produce 40,000 lbs./hr.

Each boiler will measure 17½ft. long and 14ft. 6ins. in diameter.

Provision is also being made for a fourth "Maxecon" in Shorts new boiler-house which will eventually bring the total capacity of the installation to 160,000 lbs./hr. Delivery of the three boilers is planned for June or July.

A spokesman for the firm said that the order was part of a modernisation scheme for centralising the heating systems.

\* \* \*

**THE NATIONAL Coal Board's** Director-General in Marketing, Mr. Derez Azra, says that the industry is fully prepared for the clean air legislation which the Northern Ireland Government intends to introduce.

He was speaking in the Housewarming Centre, Castle Lane, Belfast, and made the remark while pointing out the range of smokeless fuel burning appliances.

Mr. Azra said the appliances were the result of combined research by the Coal Board and the major manufacturers in Great Britain.

At the centre—which is run jointly

*Continued overleaf*

*Thirty-five*



Mark II Torch No. 1242.  
11 different heads.

This torch is the latest product under this famous name and embodies every refinement that long experience can devise, including the new patented foolproof Trigger Valve, that has **NO GLANDS OR PACKING**—cannot leak, and never requires adjustment. **MICROMETER** by-pass adjustment that saves pounds worth of gas, built-in filter that prevents stopped up jet. Interchangeable burners to give a variety of flames and, of course, the patented adjustment that makes all Bullfinch Burners **BURN PERFECTLY** on all Bottled Gases. Boxed complete.

## FLOODLIGHTS

◀ Floodlight Mk II Single

With similar features as No. 1598, suitable for **PROPANE** or **BUTANE** gas consumption, 3¼ ozs. per hour.



Double Floodlight Mark II, Ref. 1598 ▶

High intensity light beam of over 20,000 c.p. Binary lenses. Extremely portable, very light, rustproof. On telescopic stand, giving heights from 3' 6" to 6' 3". Beam angle can be instantly varied from 30° below horizontal to 30° above horizontal . . . a remarkable achievement. Most economical gas consumption. Recommended gas pressure: 14/15 p.s.i. **PROPANE** or **BUTANE**. Consumption: 7½ ozs. per hour.

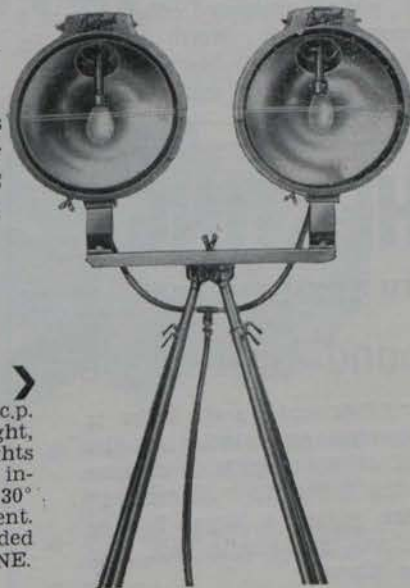

# WELDING SERVICES LTD.

14/16 AMIENS STREET, DUBLIN.  
Telephone: 47051/2/3.

# Northern Notes (Cont.)

from previous page

by the Coal Board and the N.I. Coal Importers' Association, Mr. Azra was received by Sir Wm. Scott, chairman of the Association; Mr. J. S. Kennedy, vice-chairman, and Mr. D. G. Barrett, manager of the centre.

Saying that the North imports about three millions tons of coal annually, Mr. Azra added: "We are not concerned only with selling fuel as such. We also provide a complete advisory service—a service made use of by 16,000 people during the first twelve months of the centre's existence."

\* \* \*

A SHOW HOUSE was opened in Belfast earlier this month—but one with a difference. It is the latest type of Northern Ireland Housing Trust Home. But it is not for sale! It was opened this month by Mr. Taggart, O.B.E., of the Trust, and it was arranged primarily to show the public that the local authorities of the National Coal Board and the Northern Ireland House Trust together plan for our heating and living conditions in the late 1960's.

While the heating system in the house is but one of many solid fuel systems available, it retains the tradi-

tional open fire in the lounge and utilises heat that would otherwise be wasted by heating a radiator in the kitchen and two in the bedrooms. This is in addition to constant hot water. It is hoped that the system will be fitted to many of the Trust houses.

The house has been designed by the Trust Architects and is one of a series of new types produced to comply with the latest Ministry subsidy regulations. There is, in addition, in the show house a wide range of other solid fuel appliances on display, particularly the latest types of room heaters and boilers.

The show house at Dundonald, outside Belfast, is open daily from 3 p.m. to 9 p.m. until April 21.



Mr. Walter McConnell, well known in the industrial engineering field in Northern Ireland, has joined the Belfast office of Halpin & Hayward Ltd.

\* \* \*

A recently formed company is the Building Centre of Northern Ireland Ltd., and its registered offices are at 8 Donegal Square, North Belfast. Its policy is to follow the already highly successful building centre idea.

First directors have been named as follows:—Robert James McKinstry, architect, 58 Rugby Road, Belfast; Denis Wilson Ian Campbell, architect, "Outlook," Marino, Co. Down; Brian Armstrong Harkness, chartered structural engineer, 20 Viewfort Park, Dunmurry; Arthur Eric Martin, building contractor, 22 Cadogan Park, Belfast; Ernest Harold Sidwell, civil engineer, 14 Mount Pleasant, Stranmillis, Belfast; Arthur Morgan, chartered quantity surveyor, 56 Newtownards Road, Bangor; Ronald Hislop Crawford, director, "Blue Hayes," Craigavad, Co. Down; William McFadden Martin, director, 10 Slievemoyne Park, Belfast; George Trevor Moore, chartered quantity surveyor, 58 Diamond Gardens, Belfast.

### ATTENTION MANUFACTURERS, SUPPLIERS!

Each month The Irish Plumbing and Heating Engineer will contain a comprehensive survey of the month's trade news under the "Trade Topics" heading.

We invite contributions to this column by way of news of new product introductions, of product promotions, of developments within your organisations and of appointments, to list a few.

## CENTRAL HEATING

WITH THE FAMOUS

### 'All-Around' Grate Boiler



The Willis "All-Around" grate boiler is the most powerful grate boiler on the market—proof of this claim is to examine the design—the boiler fits "All-Around" any open fire, giving a larger heating surface than any 'Back' boiler—ask your merchant, he knows.

**HEATS 3-4 RADIATORS PLUS PLENTY OF HOT WATER—FROM ONE OPEN FIRE.**

Made in Belfast by WILLIS, the Name Famous for 40 years in Open Fire Heating.

Write now for details to: Wm. Willis & Co. Ltd., 23/9 Dublin Road, Belfast, 2.

### ONE OF THE FOREMOST MANUFACTURERS OF FITTINGS FOR THE PLUMBING AND HEATING ENGINEERING TRADES

requires the services of a very well established and knowledgeable Agent, resident in N. Ireland, to represent them therein. Fullest details please to:—

**Box No. I.P.H. 28**

**13-15 DAME STREET,  
DUBLIN, 2.**

# ★ NEW INTERNATIONAL PRESSED STEEL RADIATORS

*In Single, Double  
and Treble Panels*

**EX STOCK**

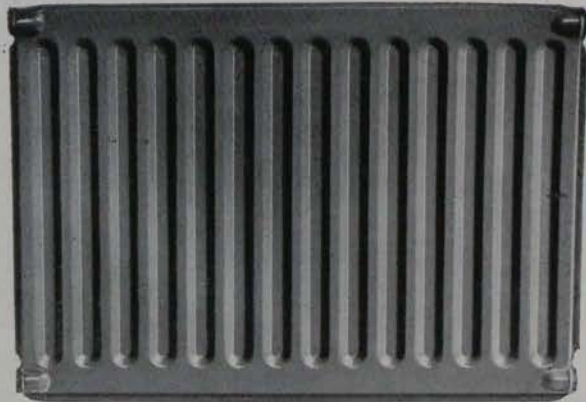

★ Also — THERMOPAK and  
SILENTFLO ACCELERATOR  
PUMPS

PRICE LIST AND ILLUSTRATED LEAFLETS ON REQUEST FROM

Sole Agents for Republic of Ireland:

## Monsell, Mitchell & Co. Ltd

67-73 TOWNSEND STREET — DUBLIN, 2. 'Phone 76282.

### a MUST in rural areas

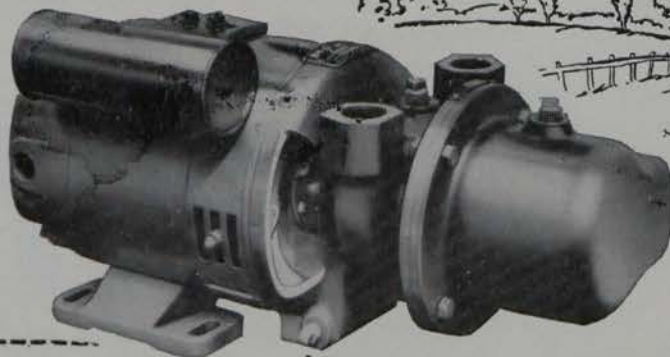

The MII Mono Pump will provide 165 gallons of water for less than a 1/2d. in power cost—sufficient water for two days for the average household. And it is self-priming with a 25 feet suction lift.

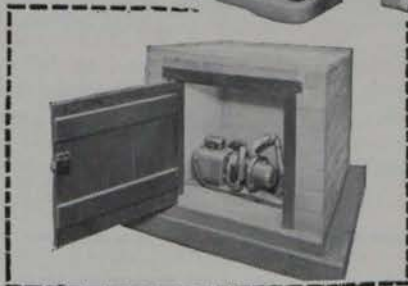

- It can be neatly tucked away in the garden—or it is silent in operation for indoor installation.
- It can also be used for pumping supernatant water from cess-pools.
- No oiling or greasing required.

*Attractive terms to dealers*

## The MONO pump

MONO PUMPS LIMITED, 31b CENTRAL HOTEL CHAMBERS, 7/9 DAME COURT, DUBLIN  
Telephone Number: Dublin 70843.

MP270/L9614

Published by Irish Trade and Technical Publications Ltd., Callaghan Chambers, 13-15 Dame St., Dublin, 2,  
Printed by The Greyhound and Sporting Press Ltd., Davis Road, Clonmel.



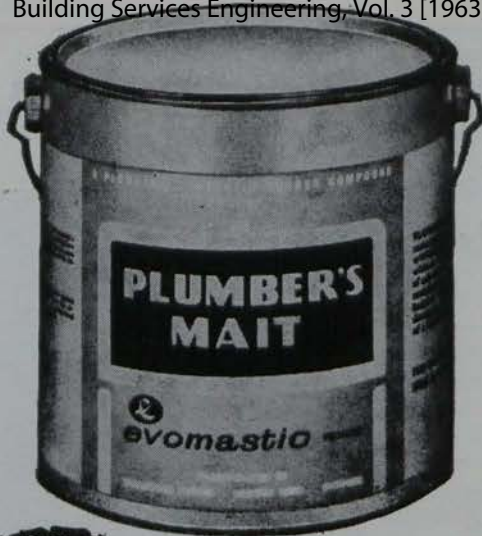

# EVERY PLUMBER NEEDS HIS MAIT!

It's PLUMBER'S MAIT – an amazing, flexible sealing compound which has wonderful qualities of adhesion and yet is clean and easy to handle.

**FAST!  
FLEXIBLE!  
CLEAN!  
WATERPROOF!  
PLUMBER'S  
MAIT  
REPLACES  
RIGID  
JOINTING!!**



PLUMBER'S MAIT will withstand excessive movements which often lead to failure with traditional jointing materials. This is because Plumber's Mait is flexible thus allowing movement within the joint. Plumber's Mait is ideal for sealing W.C. pans, taps and waste pipes, gutters, downpipes and drains, overlap joints in structures of metal, wood, glass, ceramic or plastic—on any job in fact which requires a flexible, waterproof joint, giving permanency, maximum efficiency, and all round economy.

Don't be without  
**PLUMBER'S MAIT**  
FILL IN AND POST  
THIS COUPON FOR  
FULL DETAILS NOW!

Please send full details and free sample of PLUMBER'S MAIT

NAME .....

ADDRESS .....