

5-1-1963

## The Irish Plumber and Heating Contractor, May 1963 (complete issue)

Follow this and additional works at: <https://arrow.tudublin.ie/bsn>



Part of the [Civil Engineering Commons](#), [Construction Engineering Commons](#), and the [Construction Engineering and Management Commons](#)

### Recommended Citation

(1963) "The Irish Plumber and Heating Contractor, May 1963 (complete issue)," *Building Services Engineering*: Vol. 3: Iss. 2, Article 1.

doi:10.21427/D7GH7C

Available at: <https://arrow.tudublin.ie/bsn/vol3/iss2/1>

This Article is brought to you for free and open access by the Journals at ARROW@TU Dublin. It has been accepted for inclusion in Building Services Engineering by an authorized editor of ARROW@TU Dublin. For more information, please contact [arrow.admin@tudublin.ie](mailto:arrow.admin@tudublin.ie), [aisling.coyne@tudublin.ie](mailto:aisling.coyne@tudublin.ie), [vera.kilshaw@tudublin.ie](mailto:vera.kilshaw@tudublin.ie).

# THE IRISH PLUMBER & HEATING CONTRACTOR

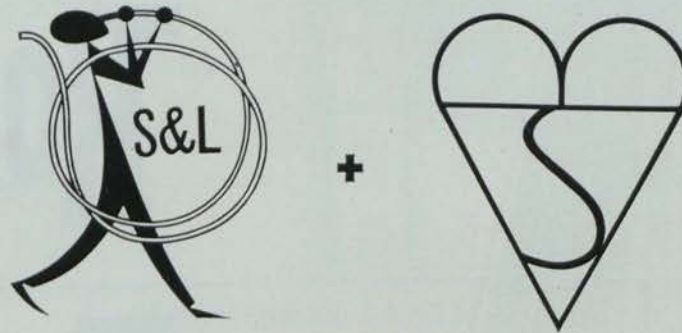

## *An Important Announcement to Architects Consulting Engineers and all concerned with Piped Water*

From March 4th, 1963, S. and L. High Density Polyethylene Pipe, manufactured to B.S. 3284, was awarded the British Standard Institute Kite Mark after passing the extra tests and inspection required for this renowned certification mark.

This Kite Mark is an additional guarantee that our pipe is made to the highest standards of manufacture and performance.

S. and L. Polyethylene pipe is not just another plastic pipe, its high density means higher tensile strength and, therefore, less material is used, giving a thinner wall, larger bore, better rates of flow and, of course, reduced costs.

### *High Density Polyethylene Pipe*

Fully approved by the Department of Local Government and Dublin Corporation  
Obtainable from all leading merchants

## **STEWARTS AND LLOYDS OF IRELAND LTD.**

EAST WALL ROAD, DUBLIN 3



# Room at the Top—

for galvanized tanks  
with a good name  
behind them :

HAMMOND LANE have years of  
experience in making galvanized tanks  
and copper cylinders—your guarantee  
of quality ! All sizes and capacities  
now available from stock.

**Hammond  
Lane  
Industries Ltd.,**

111 PEARSE STREET, DUBLIN, 2.  
Phone 75861 (9 lines).

# Not any more

They never did use small boys for cleaning boiler tubes—  
and the idea is as dated as hand brushing  
now that Airnesco brush automation is available  
for water tube boilers, waste heat boilers,  
and economic type boilers.

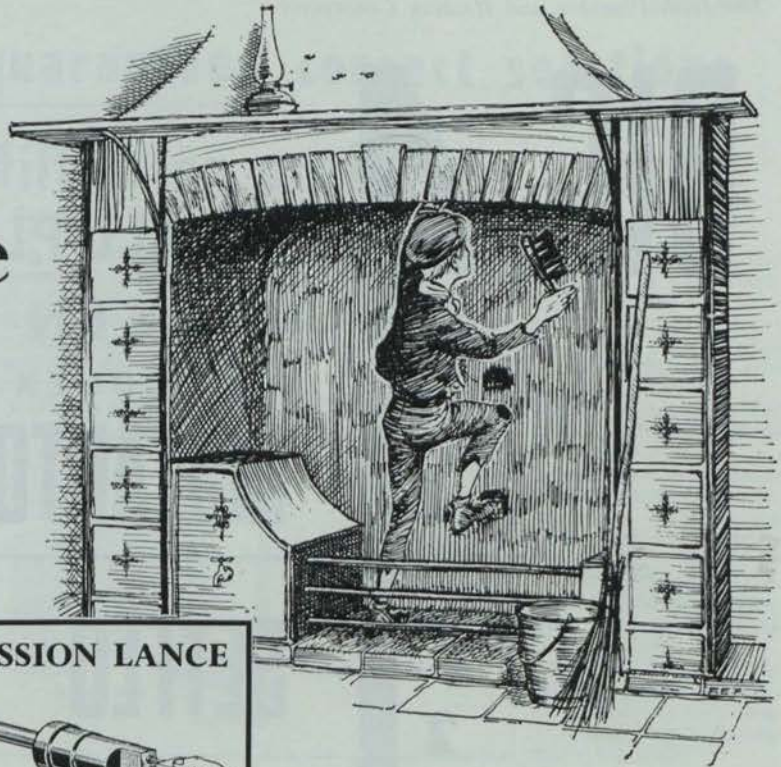

**FERRET**

\*Walks' along the tube—no pushing or pulling—the operator stands still and waits for the 'Ferret' to push itself up the tube and return to him.

**PERCUSSION LANCE**

Cleans a 300 tube fire tube boiler in 30 mins—without brushing—by air puffs alone.

**AIRNESCO PRODUCTS LTD.**

For further details of these and other Airnesco Products, and for a free demonstration in your own works, write now to

Bedford Buildings, 7 Bedford St., Belfast, 2. Tel. 26343 — HALPIN & HAYWARD LTD. — 16-17 Lr. O'Connell St., Dublin. Tel. 48638

## The **MONO** AUTOMATIC PRESSURE WATER SET

has an ideal capacity range for the average household



- ★ COMPLETELY AUTOMATIC
- ★ SELF-PRIMING PUMP
- ★ STEADY PRESSURE AT ALL OUTLETS
- ★ NO OIL OR GREASING
- ★ LOW POWER CONSUMPTION
- ★ ALL EQUIPMENT ON ONE UNIT

## The **MONO** pump

**MONO PUMPS LIMITED** (Incorporated in England)  
31b CENTRAL HOTEL CHAMBERS • 7-9 DAME COURT • DUBLIN  
Telephone: DUBLIN 70843

MP308

# BIG 4 FOR ALL PLUMBING & HEATING CHOSEN BY CRAFTSMEN

- |   |                            |  |
|---|----------------------------|--|
| 1 | <b>CONEX<br/>INSTANTOR</b> | valves and fittings for copper tubing. Equally reliable for use with plastic pipes.  |
| 2 | <b>SETFLO</b>              | radiator valves and fittings for small-bore central heating — efficient, unobtrusive and cheaper to install.                     |
| 3 | <b>CONEXCEL</b>            | fittings and adaptors. Specifically chosen for use with soft copper tubing.  |
| 4 | <b>SANBRA<br/>FYFFE'S</b>  | up - to - date range of PLUMBERS' BRASS WARE is at your stockists now. All patterns can be supplied—polished or chromium-plated. |

## ADD THEM UP TO A FIRST CLASS JOB

IT PAYS TO KEEP TO THE SANBRA FYFFE LINES

Sanbra Fyffe Limited.

Conex Works, Santry Avenue, Dublin, 9.

**VOKES**

**offer guaranteed correct solutions  
to air filtration problems**

**VOKES 'RENOVAIR' SMOKE REMOVAL UNIT**



The 'Renovair' is the latest addition to the comprehensive range of Vokes air filters, and is ideal for use in meeting halls, offices, restaurants or any building or room where people congregate. Simply switch it on and it completely clears tobacco smoke and other airborne contaminants from the atmosphere within a few minutes. And

because the Vokes 'Absolute' filter in the 'Renovair' cleans air which is then recirculated, heat loss is eliminated with consequent saving on heating bills. Please write for descriptive leaflet. Other Vokes filters widely used in air conditioning and ventilating applications include:—

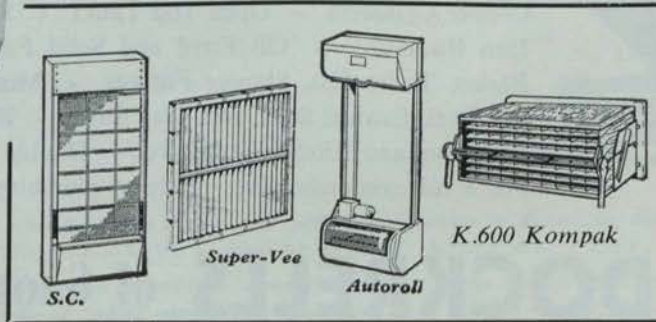

S.C.—A completely automatic filter for handling large quantities of air.

Super-Vee.—An inexpensive expendable filter panel suitable for many industrial applications.

K.600 Kompak.—A high-efficiency filter unit with replaceable filter medium.

Autoroll.—An electrically or manually operated filter combining high efficiency with low operating costs.

Full technical data available from the Sole Agents:

**THE LEINSTER ENGINEERING CO., LTD.**

158-159 CHURCH STREET, DUBLIN. 'Phone 77093/4.

**UNIVERSAL  
FABRICATORS  
LIMITED**

**STORAGE  
TANKS  
UNLIMITED**

for fuel oil  
kerosene  
petrol  
**also**

PRESSURE VESSELS  
PIPELINES  
WELDED PLATE  
STRUCTURES  
to  
A.P.I. & ASME  
specifications

Sales Distributors  
**Carthorn (1949) Ltd**

Commercial Buildings, Dame St., Dublin 2



# INVITATION . . .

We extend a hearty invitation to our many friends in the plumbing trade and all those interested in modern kitchen and bathroom furniture and fittings to visit our extensive showrooms.

Compression Joint Fittings - Copper Piping - Pipe Wrap - Copper Cylinders - Open Top Tanks - Pressed Steel and Cast Iron Radiators - Oil Fired and Solid Fuel Boilers - Baths, Basins, Toilet Sets, Shower Fittings - Mixer Fittings - Stainless Steel, Enamel Steel, Fire Clay Sinks - Blow Lamps, Solder - Bathroom and Kitchen Furniture - Double Compartment Tanks. For a full comprehensive supply of plumbing materials:

## DOCKRELLS of Georges St., Dublin

TRADE ENQUIRIES INVITED.

"Cheaper heating pumps?"  
they said -

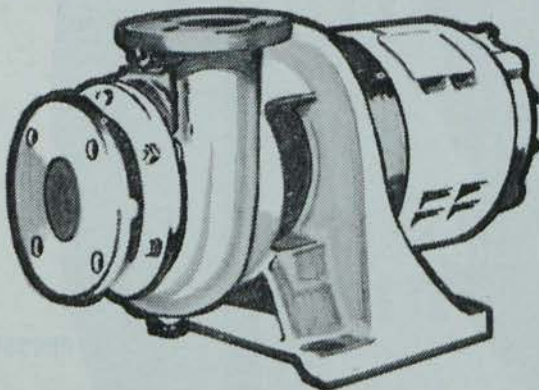

"Worthington-Simpson"  
they said

Our new range of hot water circulators is specifically designed to ensure economic operation and to promote efficiency in large heating systems. Low initial cost, simple installation and maintenance are additional money-saving factors.

- Sleeve bearings for quiet running.
- Capacities from 5 to 200 g.p.m.
- Heads from 3 to 60 feet.
- Motors from  $\frac{1}{4}$  to 5 B.H.P.—single and three-phase.

These circulators are available as compact 'Monobloc' units or in driving head construction for separate motor or V belt drive.

\* Full details and a guide to pump selection in leaflet W.S.5179

**Worthington - Simpson Ltd**



20 HERBERT PLACE DUBLIN

**Pumps • Compressors  
Heat Exchange Equipment**



Vol. 3. No. 2

The only publication in Ireland for the craftsman plumber and contractor, the heating, ventilation, insulation, air conditioning and refrigeration engineer and contractor, the electrical contractor, supplier, manufacturer and wholesaler of fittings and equipment for the trades.

Published monthly by Irish Trade & Technical Publications Ltd. Annual subscription, 21/-, post free. Single copies, 1/9, post free.

Editorial and advertising offices:  
Callaghan Chambers,  
13/15 Dame Street,  
Dublin, 2. Tel. 56465-6,  
London: J. T. Robson  
& Son Ltd., 30 Fleet  
Street, London, E.C.A.  
Tel.: Fleet Street 4438.

MAY, 1963.



# THE IRISH PLUMBER & HEATING CONTRACTOR

## IN THIS ISSUE

- The second article in our new series on Plastics in Plumbing deals with Polythene. The author is W. J. Woolgar, F.R.S.H., A.M.I.P.H.E., F.I.O.P. . . . . 10
- The cause and prevention of some of the problems encountered on the fire and water side of boiler plant were discussed in a lecture by G. T. Peat, B.Sc., F.R.I.C., to the Engineering and Scientific Association of Ireland . . . . . 22
- John G. Bolton this month deals with electrolytic action in pipelines . . . . . 25
- Still discussing domestic water supply, A. L. Townsend, M.R.S.H., M.I.P., continues with joints for pipework . . . . . 23
- Allen McDowell is the new 'Contractor' Northern Notes correspondent. His first despatch is on page . . . . . 30
- Trade Topics this month begin on page six.
- SPECIAL SURVEY: Review of pipes, tubings, fittings and jointings beginning on page thirteen.
- A lighthearted newcomer this month is the amusing "Office Hours" cartoon series, which will appear regularly.

## INDEX TO ADVERTISERS

Airnesco Products Ltd. . . . .	1	McMullans-Kosangas Ltd. . . . .	32
Asbestos Cement Ltd. . . . .	16	Mono Pumps Ltd. . . . .	1
Auto-Combustions (Ireland) Ltd. . . . .	22, 35	Monsell, Mitchell & Co. Ltd. . . . .	31
Biddle, F. H., Ltd. . . . .	7	O.B.C. Ltd. . . . .	Cover iv
Boylan, M. A., Ltd. . . . .	31	O'Brien Plastics Ltd. . . . .	15
Carthorn (1949) Ltd. . . . .	30	Pillinger, G. C. & Co. (Ireland) Ltd. . . . .	9
Chatwin, Thomas, & Co. Ltd. . . . .	12	Sanbra Fyffe Ltd. . . . .	2
Dockrell, Thos., Sons & Co. Ltd. . . . .	4	Shires & Co. (Ireland) Ltd. . . . .	29
Du Bois Co. Ltd., The . . . . .	12	Stewarts & Lloyds of Ireland Ltd. . . . .	Cover i
Fry's Metal Foundries Ltd. . . . .	23	Temple Tubes Ltd. . . . .	18
Hammond Lane Industries Ltd. . . . .	Cover ii	Unidare Ltd. . . . .	21
Hilmor Ltd. . . . .	17	Virax Outillage . . . . .	21
Leinster Engineering Co. Ltd., The . . . . .	3	Wavin Pipes Ltd. . . . .	14
Manotherm Ltd. . . . .	Cover iii	Worthington-Simpson Ltd. . . . .	4
Masser, A. H., Ltd. . . . .	19		



*The Irish Plumber and Heating Contractor.*

## Wade pumps appoint sole distributor

J. T. WADE & Son Ltd., hydraulic and general engineers, Fairfield Works, High Wycombe, Bucks., have appointed Messrs. Auto-Combustions (Ireland) Ltd., 144 Lower Baggot St., Dublin, as sole distributors here for the complete range of Wade centrifugal pumps, accessories and spares, and they in turn will be appointing stockists throughout the country.

Messrs. Auto-Combustions (Ireland) Ltd. will carry a full and comprehensive stock of Messrs. Wade's equipment to meet the needs of their customers and they will also be able to carry out repairs and give after-sales service, because they have a very well equipped workshop.

Mr. H. J. Bate is Managing Director of Auto-Combustions.

The full range of Wade centrifugal pumps were shown on the stand of

**TRADE**

**TOPICS**

Auto-Combustions at the Dublin Spring Show, when Mr. E. A. Wheeler, Sales Manager, Messrs. J. T. Wade & Son, was in attendance.

## A new Drugaser

THE DRUGASER 651 is a new wall-mounted balanced flue gas space heater, incorporating magneto ignition and flame protection control, which have proved their worth in the well-established DRUGASER JBN range of heaters. It has a rated output of 7,500 B.Th.U.'s/hr. and can be fitted with a permanent pilot if required. It is intended for operation on towns or bottled gases.

Finish: Sides mottled light olive green. Front finished old gold.

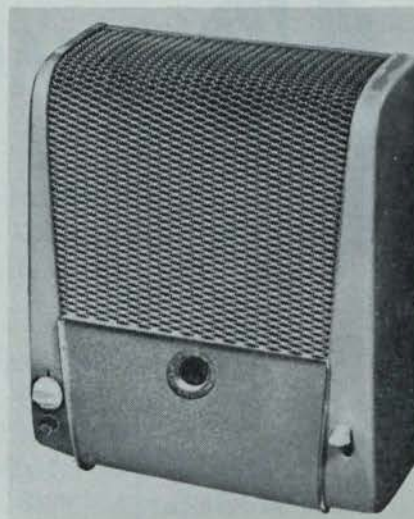

The new wall mounted  
DRUGASER 651

Dimensions: Height, 22"; width, 18½"; depth, 9¾".

Irish agents: Preston Ltd., 201 Pearse St., Dublin.



At the Shelbourne lecture were (from left): Messrs. T. Smith (Dean & Wood); S. Thuesen (Danfoss); B. J. Sampson (J. J. Sampson); and R. Steel (Dean & Wood).

## SUCCESSFUL DANFOSS AUTO CONTROLS DEMONSTRATION

THERE was a very large attendance at a lecture in the Shelbourne Hotel, Dublin, on Automatic Controls for Refrigeration given by Messrs. R. Steel and T. Smith, of Messrs. Dean & Wood Ltd., the London Danfoss agents, and Mr. S. Thuesen of Messrs. Danfoss A/S, Nordborg, Denmark, in conjunction with Messrs. J. J. Sampson & Son Ltd., the Irish agents.

Messrs. Danfoss' factory was founded by Mads Clausen in 1933 in his father's farmhouse, and now in 1963 employs 5,000. The company has 88 agents throughout the world,

and has world-wide coverage for its products.

All the leading refrigeration firms in Ireland, including Messrs. Gillett & Sons, Ltd., L. Sterne & Co., Ltd., Southern Refrigeration Company, Lightfoot Refrigeration Company, Recold Refrigeration Company, J. A. Byrne & Co., Kelvinator Ltd., A. G. Bruty Ltd., Electro Diesel Ltd., J. & E. Hall Ltd., Masser Refrigeration, Cross's Garage, Cork, and many others, were represented.

Several questions were asked and fully answered by the speakers.

## Designed for kitchen use

A NEW 45,000 B.t.u./hr. Janitor oil-fired boiler, specially designed for installation in the kitchen of a three-bedroomed house, is announced by Powell Duffryn Heating Ltd. The Janitor 0.45 is a fully automatic boiler with electric ignition and the burner used, which is of the fan-assisted pot type, is exceptionally quiet.

The Janitor 0.45 is supplied by the manufacturers completely assembled and with all the internal wiring already carried out. To facilitate servicing, all the electrical devices are plugged into the control box. The latest version of float level control, which regulates the supply of oil to the burner, is used and this incorporates a solenoid operated shut off valve to prevent any oil flowing into the burner pot when the burner is shut down by the thermostat. A further refinement on this control is the use of a heat motor time delay operating on the fan so that on shut down the fan keeps running for a short period after the oil supply is shut off to make certain that all the oil already in the burner pot is thoroughly burnt.

Ignition of the oil is a by glow plug igniter which is permanently heated, thus making certain that when-

*from previous page*

ever there is oil in the pot it will ignite.

The thermostat dial, which is the only control the user needs to touch, is behind the easily opened front cover to protect it from accidental alteration.

An estimate of running costs would be of the order of £70 per annum.

Irish agent: D. H. Sullivan, Esq., Green Park, Coleville Road, Clonmel, Co. Tipperary.

## Vauxhall boiler name change

THE VAUXHALL Boiler Co. Ltd. announce a change of name for their Golcalor fully packaged hot water boiler. This will be known and sold in future under the name of Vauxhall Ambassador. The change is due to the fact that the company discontinued their connection with their Swiss Correspondents some time ago, the main interest of the Swiss Company being in the dual purpose boilers for direct hot water supply, as well as central heating from the same unit. The change is limited to the name, with no effect on the design or on the outstanding features of these boilers.

Due to the considerable success and demand, it has been found necessary to extend the range of these units up to 3 million B.T.U.'s per hour from the previous 2 million B.T.U.'s per hour. They are now also available with a choice of burners, either Brockhouse pressure jet or medium pressure air, or Urquhart's medium pressure air type, employing the principle of toroidal combustion.

Irish agent: P. J. Casey, Esq., 38 The Rise, Mount Merrion, Dublin.

## Versatile mixers from Barwell

THE DECK Pattern Combination sink mixer fittings manufactured by James Barwell, Ltd., are now available with either a tubular (No. 1305T) or a die-cast (No. 1305D) spout, both of which have entirely separate waterways.

Either spout can be fitted to replace the other in a matter of seconds, as the patented leak-proof device secur-

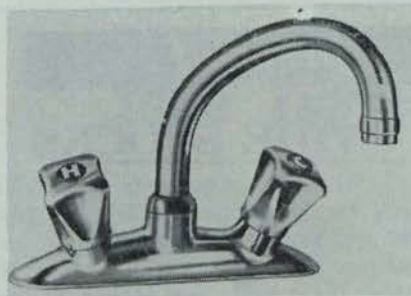

The Deck Pattern combination sink mixer fitting (No. 1305T), by James Barwell Ltd.

ing spout to body does not require a retaining nut.

**TRADE**

**TOPICS**

*Continued overleaf*

The Barwell Deck Pattern fittings have control traps leaning both outwards from the centre, and forward—a design which avoids any obstruction at the back of the sink.

Irish agent: C. B. Sheridan, Esq., 10 Herbert Place, Dublin.

THE way we make heating and cooling coils is unconventional. The tubes pass through a series of perforated plates mechanically bonded by a special tube expansion process. Result—a perfect metal to metal contact that no amount of expansion or contraction can affect. Also, a more than usually efficient and uniform distribution of heat from a more durable unit. The choice of tube metal, of size and capacity, is up to you. There is, of course, a standard range and it is a very extensive one. For details please write or 'phone any of the addresses below, Dept. IP2.

**COIL FINNS THAT DON'T SPIRAL & ARE ALL THE BETTER FOR IT! . . .**  
**BIDDLE COILS**

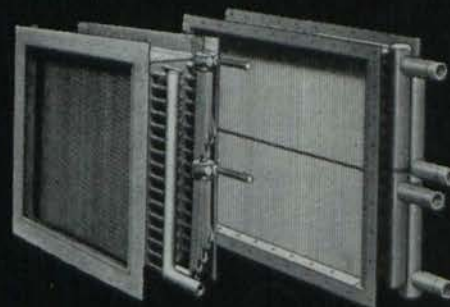

**BIDDLE** Quality controlled products

**F H BIDDLE LIMITED**  
(British Trane Co Ltd—  
Manufacturing Division)  
16 Upper Grosvenor St. London W1  
Hyde Park 9532

Technical Representatives  
**D. H. BUTLER**  
7 Blackwood Crescent, Helen's Bay, Belfast Helen's Bay 2119  
**QUADRANT ENGINEERS**  
167 Strand Road, Sandymount, Dublin 4 Dublin 693940



The Irish Plumber and Heating Contractor.



## Sigmund Appoint Technical Rep

MR. N. A. SPILLER has been appointed technical representative for the whole of Ireland for Sigmund Pulsometer Pumps Ltd., Gateshead.

Mr. Spiller, who is well known in the engineering field in Ireland, will cover the Twenty-six Counties and Northern Ireland, working from the company's new office at 128, Gt. Victoria Street, Belfast.

## New look for old book

"PRACTICAL NOTES on Leadburning for Plumbers," the well-known text-book on leadburning, has been reprinted for 1963 in an up-to-date format and with a striking new cover. Leadburning has had a greatly increased application in building work and domestic plumbing over the last 20 years, and the technical advantages and economies in both solder and labour that it makes possible are now widely appreciated.

Copies may be had from the Lead Development Association, 34 Berkeley Square, London, W.1.

## in brief...

### WIDE STOCKS

SIMPLIFIX Couplings Ltd., the well known manufacturers of pipe fittings, valves and hose fittings, announce that their agent, Mr. F. M. Marr, 6 Herbert Place, Dublin, is now carrying a wide range of stocks.

★ ★ ★

MESSRS. Technical Sales Ltd., 79 Lower Leeson Street, Dublin, have been appointed Irish agents for Bahco Ltd., Bahco House, 23, Goswell Road, London, E.C.1, manufacturers of a wide range of air conditioning and ventilating equipment.

★ ★ ★

VEHA LTD., Jamestown Road, Finglas, Dublin 11, are now stocking a number of panel radiators from their very large range in order to facilitate their clients who might from time to time require exceptionally quick delivery. The range of radiators for "stocking" has been selected particularly with the "domestic heating job" in mind, and the list of these is available on application.

★ ★ ★

W. Finucane & Co., 5 Upper Pembroke Street, Dublin, 2, have been appointed Irish agents for Girdlestone Pumps Ltd., Woodbridge, Suffolk.

★ ★ ★

ROPER BROS., Ltd., 5 South Anne St., Dublin, now have works-trained staff in their repair shop for the purpose of overhaul and repair of Venner Time Switches. Charges are reasonable, and under normal circumstances a 24-hour service can be offered.

## International Extend Again

INTERNATIONAL Boilers and Radiators Limited are building a further extension to their Gateshead Works to meet the increasing demand for their radiators. Production last year broke all records and is continuing to do so this year, say International. The new extension will be completed by the end of June in time for the new heating season.

## Shires develop new ball valve

A NEW versatile plastic diaphragm ball valve suitable for all makes of toilet cisterns has been developed by Shires of Guiseley. Known as the "Heron," it is made of "Delrin," a dimensionally stable material which is one of the toughest of all thermoplastics, and is the first ball valve to be produced in this new material.

The "Heron" is durable, will not corrode or stick, is extremely quiet in operation and has been designed to withstand many years of use. It can be completely dismantled without disturbing the connection to the cistern and will also take a standard silence tube and a compression fitting for copper.

No manual bending is necessary and the brass screwed arm adjusts laterally from  $\frac{1}{2}$  in. to 1 in., and vertically from 3 in. to 6 in. Tested to over 300 p.s.i., The "Heron" is suitable for all makes of cisterns and is accepted by leading water authorities.

Irish office: Shires & Co. (Ireland) Ltd., Stannaway Drive, Crumlin, Dublin.

# 1963

## Directory of Manufacturers, Agents, Representatives and Distributors

### NEXT MONTH

The Irish Plumber and Heating Contractor will contain the revised 1963 Directory of Manufacturers, Agents, Representatives and Distributors. Many new headings have been added and much additional data is contained in this comprehensive Directory. Additional copies of this year-round reference issue may be ordered now from the Irish Plumber and Heating Contractor, 13-15 Dame Street, Dublin, 2.

## TRADE

## TOPICS

### BSA acquire control interest in Harford

THE BSA GROUP announce the acquisition of a controlling interest in one of their associate companies, Harford Pumps Ltd. of Charlotte St., London, W.1—a move which highlights the Group's growing interest in the central heating market.

Harford are a sales organisation marketing a variety of central heating equipment, most of which is made by BSA firms. The principal product marketed is a small pump developed from a Swedish design, which is used to circulate water round small bore heating systems.

The pump has been made by BSA Small Tools Ltd., Birmingham, since 1960, using specially installed, highly-automated plant, the bulk of which is of BSA Tools manufacture.

Last August a new model was introduced—the Opimatic—which has been developed by BSA and Harford. Heavy orders for this pump has necessitated further increases in production.

Irish agent for Harford Pumps: G. A. Reid, 16 Fade St., Dublin.

### NEW THREADING TOOLS OFFERED

THE MANUFACTURERS of Presto threading tools, Easterbrook, Allcard & Co. Ltd., of Penistone Road, Sheffield, 6, now offer two types of polythene threaders, one which comprises a light alloy diehead with high quality carbon steel radial type precision chaser dies. Each diehead is a complete unit and is offered in three sizes—i.e.,  $\frac{1}{2}$ ",  $\frac{3}{4}$ ", and 1" B.S.P. tr.

As an alternative the Presto circular diehead produced in malleable iron, is a robust tool. These tools comprise circular solid dies that fit these dieheads and thread polythene of the following sizes—Set No. 1:  $\frac{1}{2}$ ",  $\frac{3}{4}$ ", 1" B.S.P. tr.; and Set No. 2:  $1\frac{1}{4}$ ",  $1\frac{1}{2}$ ", 2" B.S.P. tr.

## Save Time and Trouble

### INSTALL 'PETROMETER' Remote Reading Tank Gauges On Your Fuel Oil Storage Tanks



#### Take Advantage of these Features:—

Large, easy-to-read vertical scale gives tank contents at a glance. Eliminates the cumbersome measuring stick. The gauge can be installed at any elevation and up to  $\frac{1}{4}$  of a mile away.

No troublesome moving parts—operates on the sound principle of the U-tube. Simple, dependable and accurate.

Easy to install—the tank assembly for the gauge can be installed when the tank is empty or when containing liquid. It can also be installed separately to complete the tank work. The gauge can be connected any time later. Just tighten one simple connection and the job is complete.

For Tanks 20 inches to 50 feet deep.

STANDARD MODELS SUPPLIED FROM STOCK

## G. C. PILLINGER & CO. (IRELAND) LTD.

20 Sycamore Street, Dublin

Phone: 77007-8-9.

BRANCH OFFICE: 35 South Terrace, Cork.

Phone: 23955.

*The Irish Plumber and Heating Contractor.*

**P**OLYTHENE and polyvinyl chloride (P.V.C.) pipes are the first additions to the traditional range of appliances used for conveying water and waste for the last three decades. All the traditional materials have their disadvantages, particularly when used for this purpose, and in general plastics compare favourably with them.

**Properties.** — First, unless metal pipes are suitably protected they will corrode when buried in the earth or encased in materials which cause corrosion. Polythene, on the other hand, cannot be affected by either soils or water. In all types of water supply it is important that the pipe should not be adversely affected by prolonged contact with water. With metal pipes, when the water contains chalk and lime, deposits are formed which can lead to the complete blockage of the pipes under certain conditions; for example, when the dissolved carbon dioxide is released in a domestic hot water system. If the pipe is rough-bore, the scale that is deposited tends to stick, and moreover rusting is encouraged. These troubles do not occur with polythene.

The effects of various metals on the taste and smell of water, and the possibility of their dissolving and poisoning it, are also matters of much importance. Soft, acidic waters dissolve lead, and in many cases have to be treated to make sure that this cannot occur. The D.S.I.R. Report states that polythene does not affect the odour or taste of either treated or untreated water, and that it does not involve a toxic hazard.

#### SLIGHTLY ELASTIC

**M**ETAL pipes are good conductors of heat, and it is necessary to insulate them if they are not to freeze. Polythene is a good thermal insulator, and water will take much longer to freeze in polythene than in metal pipes. Moreover, the fact that polythene is slightly elastic means that it is able to accommodate the expansion

# Polythene

which occurs when water becomes ice, whereas metals would be liable to split under the pressure. Experiments and practical experience have shown that water can be repeatedly frozen and thawed in polythene pipes without them bursting.

Polythene is light and resilient, and it will withstand quite an amount of rough handling and usage without distorting. On the other hand, care must be taken, particularly with low density polythene, to see that the pipe does not sag between supports.

The design of pipes in materials that creep as do lead and polythene is influenced chiefly by the material's initial strength and by its long-term performance under stress. The design of any type of pipe may be based upon a limiting strain rather than on the avoidance of a fracture within a prescribed time. With polythene, creep depends to some extent upon the material's molecular weight, while that of lead depends, or rather is influenced by, its crystal structure, and by whatever alloy constituents it may contain. Although lead may have a superior short-term strength, compared with polythene, it is a less good structural material when ultimate creep and elongation of fracture are considered.

Polythene is eleven times lighter than lead, and low density polythene has a softening point of about 80°C. This means that it can be used only for carrying liquids below the temperature of 65°C or 149°F.

In the sizes normally used— $\frac{1}{2}$ -in. to 2-in. bore—its lightness, flexibility,

and the fact that it is available in long lengths are valuable in that they help to reduce handling costs. When the pipe can be installed underground by means of a mole plough these factors combine to make unnecessary the costly business of digging trenches.

#### THE MANUFACTURE OF

#### POLYTHENE

**P**ETROLEUM is the basic raw material from which polythene is derived. It is produced when the hydrocarbon gas ethylene ( $C_2H_4$ ) is polymerized on its own at high temperature and pressure.

In the polymerization process the gas ethylene is supplied to the first stage of the plant at atmospheric temperature and at a moderate pressure. It is then compressed in normal multi-stage compressors to between 1000 and 3000 atmospheres. The gas is pumped by compressors to the reaction unit, and the catalyst is introduced separately. A molten, viscous polymer is produced. This is extruded from the reaction unit in a continuous ribbon, solidified by cooling and cut into granules. The product may undergo further processing for homogenization, or for the incorporation of a pigment such as carbon black when the polythene is to be used for piping.

#### THE PROCESS

**P**OLYTHENE tubes are manufactured by a process similar to that used for the extrusion of metal pipes in that an extrusion die is used. The

**PLASTICS  
IN  
PLUMBING**

**2**

**WE HAVE SECURED SERIALISATION**

**RIGHTS OF THIS IMPORTANT WORK BY**

**W. J. WOOLGAR**

**F.R.S.H., A.M.I.P.H.E., F.I.O.P., R.P.,**

**a former lecturer in charge of sanitation and plumbing courses at the Northern Polytechnic.**

from previous page

actual process can be briefly described as follows. Polythene in chip, granular, or any other convenient form is fed continuously into the screw or screws of a suitably heated and adjusted extrusion machine. There it is converted into a homogeneous molten mass under pressure. It is then forced through a screen and thence to the extrusion die orifice. It may be noticed that because of its physical properties polythene is one of the easiest thermoplastics to handle in an extrusion machine.

After the polythene leaves the extrusion die it is drawn under controlled tension into and through a cooled forming device, where the pipe is continuously sized and set to the required bore and thickness. This operation is followed by further controlled cooling, and the pipe is finally arranged in coils or in straight lengths, according to its diameter.

**THE GRADING OF POLYTHENE**

**P**OLYTHENE pipes made to B.S. 1972 for water services can operate at mean working stresses of 150-300 lb./sq. in., calculation of the stress being based on a low level of diametric strain during their service life.

There are various commercial grades of polythene; these are differentiated according to their molecular weight. In general, the higher the material's molecular weight the better its mechanical performance and to some extent its resistance to chemicals such as oils. Since, however, increase in molecular weight is accompanied by a corresponding increase in melt viscosity, the improvement in the substance's physical properties is offset by the fact that it is more difficult to process and work. The numbers given to the different grades directly indicate this relationship between the average molecular weight and melt viscosity. They are in fact an index of the weight (in grammes) of molten polythene that can be extruded in a

**TABLE 1—Properties of Polythene compared with those of Traditional Metals.**

Property	Lead	Iron	Copper	Polythene
Specific gravity	11.4	7.9	8.9	0.92—0.96
Thermal conductivity	0.08	0.145	0.92	0.0007 c.g.s. units
Linear coefficient of expansion	33 × 10 <sup>-6</sup>	12 × 10 <sup>-6</sup>	20 × 10 <sup>-6</sup>	18 × 10 <sup>-5</sup>
Melting point	327°C	1535°C	1083°C	111—125°C
Specific heat at 20°C	0.032	0.11	0.093	0.55
Tensile Strength	2200	50,000	45,000	2000—5000 p.s.i.
Corrosion resistance	Good	Poor	Fair	Excellent
Flexibility	Fairly Flexible	Rigid	Rigid	Flexible
Effect of water	Serious with Soft Water	Very Slight	Little except under Acid Conditions	None
Frost resistance	Will Burst	Will Split	Probable Failure	Excellent

given time, through a given orifice, at a given temperature, under a given pressure. The higher the molecular weight, the greater the viscosity of the molten material; the greater the viscosity, the slower the flow and the smaller the quantity of polythene extruded. The smaller the quantity extruded, the lower will be the polythene's grade, and the better its physical performance. It can be seen from the table that grade 2 polythene has the optimum performance of all the standard grades.

**GAUGES**

**N**ORMALLY, there are two gauges of black polythene tube for use in water services, and for flush pipes, overflow and warning pipes: normal gauge tube and heavy gauge tube. Most methods of jointing other than

screw threading may be used for normal gauge tube, and the heavy gauge may be screw-threaded to B.S. 21, B.S. 142, and B.S. 1256, as well as being suitable for connection by most other means.

**POLYTHENE PIPE TO BRITISH**

**STANDARD 1972: 1961.**

**T**HE British Standard 1972: 1961 specifies the weights and working pressures of each type of tube; and also the outside diameters and wall thicknesses.

The outside diameters and wall thicknesses are subject at any point to fine tolerances plus and minus.

The tubes have to be clearly and durably marked, at intervals of not more than 20 ft., with the manufacturer's name and the British Standard number. This may be done with either paint or a stamp. The normal gauge tube is marked in red, and the heavy gauge in blue. This marking can only be done under licence, and ensures that the product complies with the requirements of the Standard.

Normally the tube is manufactured in standard coils of 100 ft., 250 ft., and 500 ft. Since polythene has a low

*Continued page thirty-five*

*Eleven*

**TABLE 2—Polythene Grades and Contributory Data.**

Melt Index	2	7	20	70	200
Melt viscosity (poises)	30,000	10,000	3,000	1,000	300
No. average molecular weight	32,000	28,000	24,000	18,000	14,000
Inherent viscosity	0.95	0.85	0.76	0.64	0.58

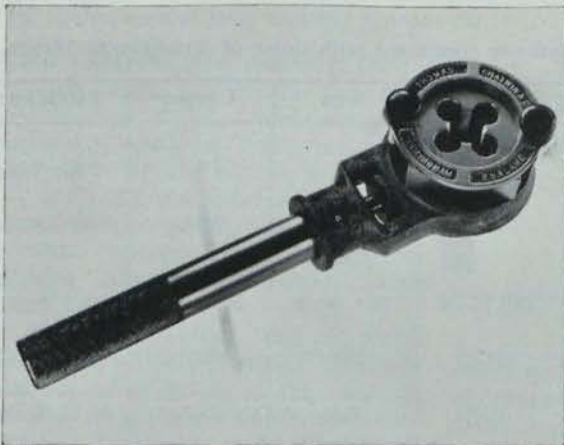

## 418 PATTERN RATCHET DIESTOCK

Better threads, easier cutting, and quick and simple die and guide changing are the attractive features of this Chatwin product. The 418 Pattern Ratchet Diestock and die must satisfy the need for a tool which makes pipe thread cutting economical. Dies are available for the standard range of B.S.P. threads and alternatively, to Whitworth, U.S. standard, and Unified, within capacity of stock.



*Ample Strength for the TOUGHEST JOB*



## STILLSON PATTERN PIPE WRENCHES

Heat treatment of the handle and jaw gives correct degree of hardness and prevents bending and breakages. Sturdy, light in weight and easy to handle, these wrenches are guaranteed against defects in material and workmanship.

**THOS. CHATWIN & CO.**

Victoria Works, Great Tindal Street, Birmingham, 16  
Telephone: Edgbaston 3521-3

ONE OF THE **BROCKHOUSE** COMPANIES

A NEW  
PRODUCT

# "THE DUBOIS PLASTIC TRAP" (Regd.)

A NEW  
PRODUCT

Provn. Pat. No. 38070/60.

1½" and 1¼" diam. x 1½" seal "S" and "P" BLACK HIGH DENSITY PLASTIC TRAPS



Orthodox Shape!  
Smooth Bore Tubular construction.  
Outlets can be turned through 220°.  
A two-piece trap at a one-piece price.  
Outlet on 'S' trap turned to inlet forms a through-bore bottle trap.  
Frost and damage resisting.  
Light weight = lower transportation costs.



Manufactured by:—

**THE DU BOIS COMPANY LIMITED**  
15 Britannia Street, London, W.C.1



## AN IRISH PLUMBER & HEATING CONTRACTOR SPECIAL SURVEY

### REVIEW OF PIPES, FITTINGS AND JOINTINGS

# CONTINUED WISE USE ACCORDING TO PROPERTIES

**A**PART from the comparatively recent addition of Pitch Fibre and P.V.C. to the range of materials for pipes, we see very little change. Cast iron, mild steel tubulars, copper tubes, lead pipe, each according to its own properties, continue to be wisely used where circumstances require.

The new materials, Pitch-Fibre for soil pipework and drainage, and P.V.C. for waste drainage, cold water mains and cold services, seem to forge ahead in selection and use where speed of installation and freedom from corrosion are essential tube properties.

But the others do not lag in development and progress is being made to speed jointing methods in these too.

### Improvement

**F**ITTINGS show a marked improvement in many cases where enlightened manufacturers are taking time off to find out just what kind of fitting the man on the job really wants. This move is to be applauded and, although long overdue, it will reduce the range of fittings to be held in store and it will stop the frustrating, expensive business of having to "cob-up" several fittings to do the work of one had it been so designed.

An example, one of many, is the "Jevco" combined elbow-M.T. plug. A simple enough fitting yet it gets over the job of bending the return back into the boiler whilst at the same time providing a drain down point. All this in one neat fitting which otherwise requires an elbow, tee, and drain cock to accomplish.

The new "Jevco" list No. 63/4/C

shows this fitting along with several other equally useful and time-saving. A combined coupler/M.T. plug as shown in this list will be a boon to those who rightly provide drain points at the low end of all unavoidable dips in water services—this is an essential frost damage precaution, of course. The new coupler/drain cock simplifies the provision of this need on site, and in a neat, quick and economical way.

An inspection plug elbow, very useful in basin range waste layouts, is yet another sound idea listed, and a swivel boiler tee will be found very handy for vent and hot-water draw-offs from hot store vessels.

### Practicality

**A**LL indicate careful thought in design with emphasis on practical application value.

Combined stop tap-drain taps are another essential frost precaution fitting which should be in standard use in all new cold water installations, and should be used in replacement of older stop-tap arrangements in existing work.

Such fittings are not new to the trade but many presently available ones are a bit pricey. The old way

of providing a separate drain tap connection above the stop-tap was wasteful on time, fittings, or both and even the higher priced combined stop tap-drain tap fittings showed a saving over the older, and less effective, separate drain tap arrangement. The "Jevco" list shows two alternative fittings, both very competitively priced.

"Peglers" have obviously been equally busy with practical research and have come up with some simple, yet really valuable improvements in radiator valve design.

Small-bore heating continues to enjoy its well deserved popularity but it is a pity that some, in honest endeavour to keep prices down, no doubt, are not advising clients on the wisdom of having two valves to each radiator. One valve as a manual control for the occupants of the room to operate as required, the other—a lockshield valve which can be used as a balancing valve or, in case of defective rad, can be used with the manual valve to isolate the radiator without interfering with the working of the rest of the system.

### Flexibility

**N**O one looks forward to the day when a radiator might "go for a Burton," and such is a flexibility of modern circulators to cope with even none-too-well designed circuits, that in many cases the second or lockshield valve is not fitted to radiators as standard practice, yet reasonable results obtain. And yet the cost of the valve is not great—the cost of

## NEXT MONTH

Directory issue of Manufacturers, Agents, Representatives and Distributors of Plumbing Equipment and Sanitaryware. Also Heating, Air-Conditioning, Insulation and Refrigeration Appliances and Materials.

## NEXT MONTH

Continued page fifteen



*The Irish Plumber and Heating Contractor.*

## “Still living in the thirties, Dad?”



Look, the way to make money in plumbing is to cut your costs of materials. Right? And cut your labour-time. Right?

**RIGHT!** It's easy. Turn to the Wavin system and forget all other forms of piping. Why?

**YOU SAVE ON MATERIAL—** You can buy Wavin hard PVC Pipe for as little as 2½d a foot.

**YOU SAVE ON TIME—** Wavin is easy to transport and handle. It can be joined—permanently—in seconds.

**YOU HAVE A COMPLETE RANGE—** Wavin is a complete system. Your stockist carries everything a plumber needs for any job.

**YOU SAVE YOURSELF TROUBLE—** All the modern Plumber needs is a hacksaw and a tin of cement. In short, for a water or chemical plumbing job, Wavin is the cleanest, quickest, neatest, most convenient money-earner. Quote on Wavin!

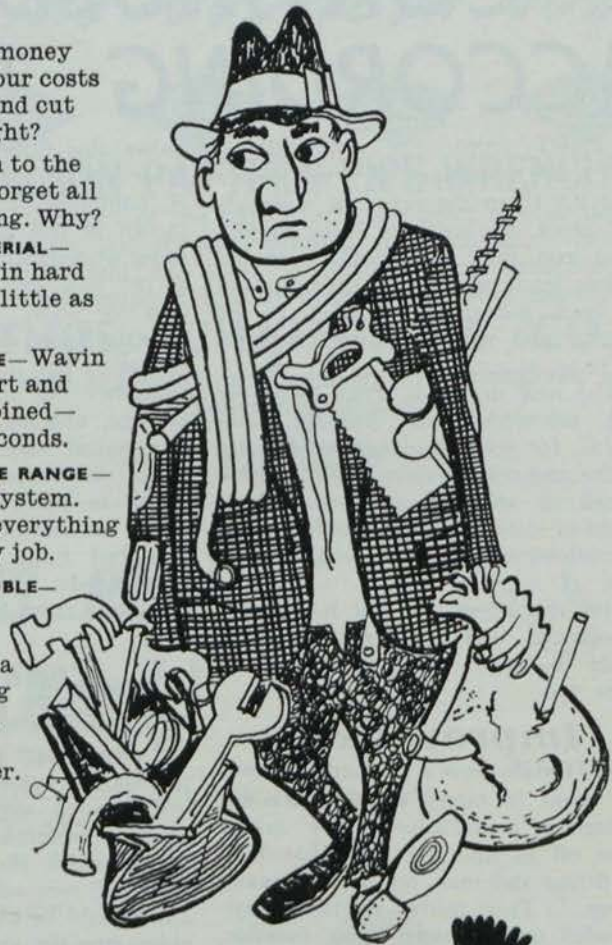

# wavin

*worth looking into ...*

WAVIN PIPES LIMITED (Head Office and Works) BALBRIGGAN. Telephone 212260.  
Also at London, Liverpool, Lisburn.



*This special survey—another in a series on important aspects of the plumbing and heating trades—has been compiled by technical expert A. L. Townsend, M.R.S.H., M.I.P.*

*From page thirteen*

half-a-dozen should not sway acceptance or rejection of an estimate for small bore—but they are well worth having.

“Peglers” have just put on the market some really pleasing radiator valves to B.S.2767. These replace existing fittings of traditional pattern and exemplify what can be done when a manufacturer sets about meeting the specific need of the trade.

One basic valve pattern is adaptable to manual control or lockshield application. A quick, simple, interchange of “head” brings about the conversion of one to the other—and this only by changing the “handle” or “lockshield” part of the valve headgear—not the entire headgear.

### **Important**

**BODIES** and headgear are identical and of full way construction—an important design point.

The “heads” or interchangeable “handles” are in bakelite and pleasantly up to date in appearance. They will interchange with  $\frac{1}{2}$ in.,  $\frac{3}{4}$ in., and 1in. valves. This is design for the trade with a will to satisfy—it is a welcome trend.

Out of the same stable comes another radiator valve in straight or angled headgear. This too has been purpose developed for small bore central heating use. It features: easy to turn, non-heating “handles,” wheels or control “heads”; a screw-down action, and positive shut off. Thus Peglers “Belmont” valve incorporates the interchangeable “head” idea outlined above.

Another interesting feature is that the valve turns full “on” or “off” in only  $\frac{1}{4}$ in. turn, and a clearly seen indicator label in the “head” shows how the valve can be regulated from “off” to “1, 2, 3” heat position. This idea must prove very helpful to the householder lucky enough to have an installer wise enough to see the value of good standards in domestic heating practice, i.e., a job which is efficient yet easily managed by the non-technical householder.

### **Specials**

**STILL**, on small bore heating, the specially devised fittings by “Yorkshire Imperial Metals” are worth looking at. More than that, they are well worth including in any truly well designed installation. Fit-

tings such as venting fees and drain cock tees, respectively. Both are of the well known and well tried “Yorkshire” solder capillary fitting kind which have lent themselves to

*Continued page seventeen*

# PIPE WATER

**Where and when you want it  
—with Plastic Tubing for all  
Cold Water Services**

## **1 ‘POLYFLOW’ POLYTHENE TUBING**

—Low Density to B.S.S. 1972.

## **2 ‘POLYFLOW’ POLYTHENE TUBING**

—High Density to B.S.S. 3284. Table 1.

## **3 P.V.C TUBING SERVICE PIPING**

—Up to 2”.

Manufactured by:—

**O'BRIEN PLASTICS LTD.  
CORK**

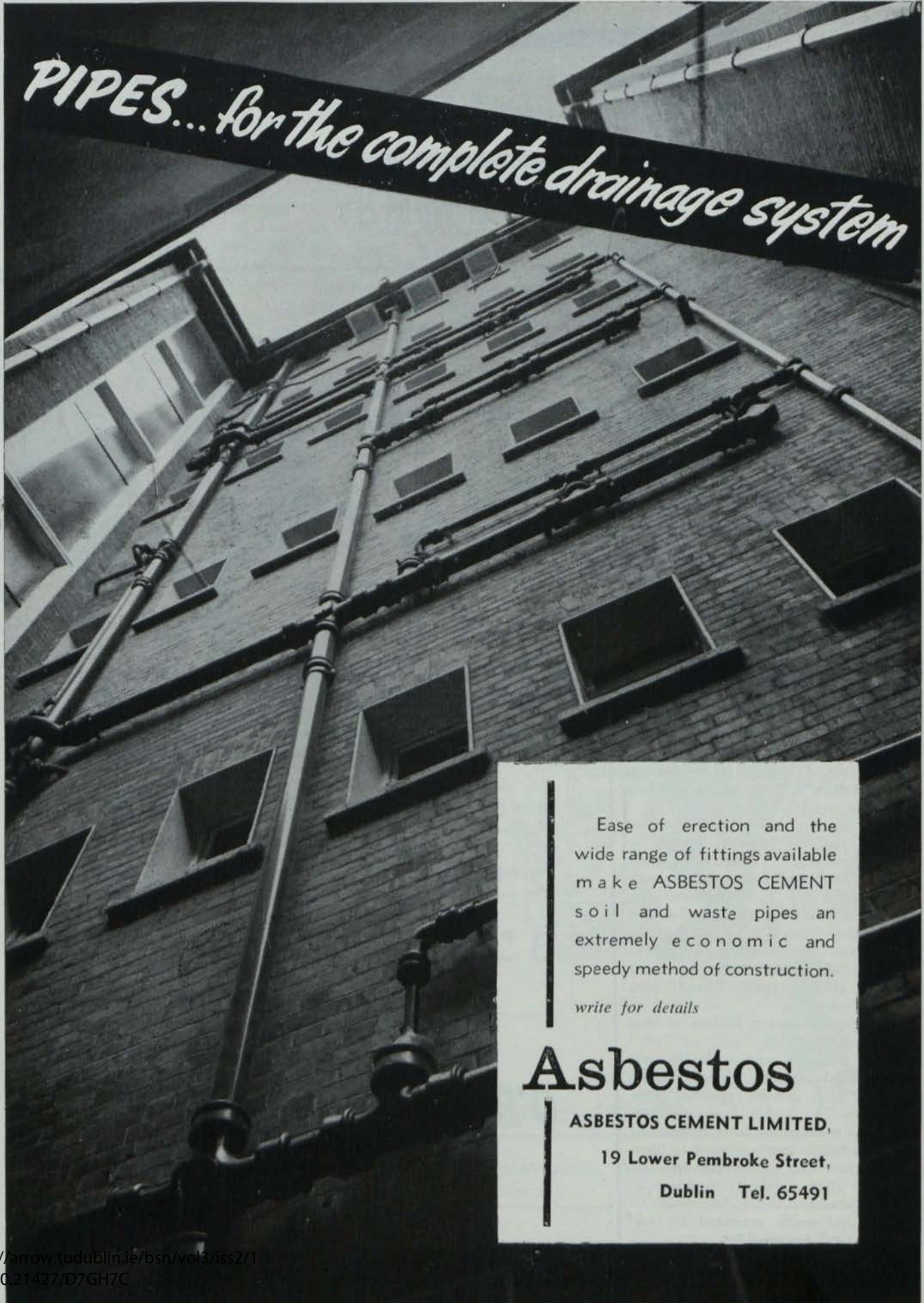

*PIPES... for the complete drainage system*

Ease of erection and the wide range of fittings available make ASBESTOS CEMENT soil and waste pipes an extremely economic and speedy method of construction.

*write for details*

## **Asbestos**

**ASBESTOS CEMENT LIMITED,**

**19 Lower Pembroke Street,**

**Dublin Tel. 65491**

quick, neat, and profitable small bore installation. *from page fifteen*

Whilst on solder capillary fittings we note that Kay Co. of Bolton have introduced a new fitting with two integral solder wings. Made from gun-metal especially to withstand exposed or corrosive conditions in hot or cold water services—the new “Kon-Kay” fitting should be a useful addition to the light gauge copper tube range.

Before leaving hot and cold water installation pipework and fittings, it is worthwhile to pause and reflect upon the havoc wrought by the “Big Freeze” of 1963.

No doubt many lessons were painfully learned from that cold spell. If most of these are applied to advantage in future work, then something useful will have come out of that appalling weather. Such things as stop tap/drain tap provision, the

avoidance of dipped pipes which cannot be drained—or the provision of drain cocks to unavoidable dips, and the placing of pipes away from cold walls, attic spaces, and chilling draughts, all these things need thinking about even when the sun is hot on our backs. Not to do so is to invite a repetition of frozen pipes, no water supply, and all the attendant discomforts of these.

## NEW PRODUCTS WORTH STUDY

### PORTABLE TUBE BENDERS

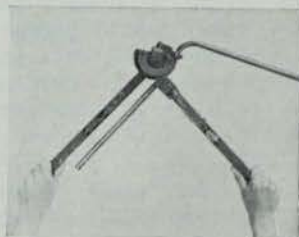

#### LIGHTWEIGHT BENDING TOOLS

Types GL.O and GL. Minor

Compact machines to produce good quality sets, compound bends, etc., in non-ferrous tube. Robustly built, they can be carried in tool bag and are particularly suitable for small bore heating and similar types of installation.

**CAPACITY:** GL. O— $\frac{1}{4}$ ",  $\frac{3}{8}$ " and  $\frac{1}{2}$ " dia. copper tube.  
GL. Minor— $\frac{1}{4}$ " and  $\frac{3}{8}$ " dia. copper tube.

#### FOLDING STAND MODELS

Types GL. 2B and GL. 3B

The original and most efficient portable benders made for bending light gauge copper tube. Require no fixing or bolting down and produce good quality bends, cold and unfilled, to exact measurement on standard radii.

**CAPACITY:** GL. 2B— $\frac{1}{4}$ ",  $\frac{3}{8}$ " and 1" dia. copper tube.  
GL. 3B— $\frac{1}{4}$ ",  $\frac{3}{8}$ ", 1", 1 $\frac{1}{4}$ " and 1 $\frac{1}{2}$ " dia. copper tube.

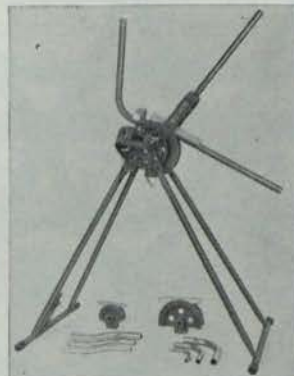

#### EASY-WORK RATCHET BENDER

Type RP. 5B

A machine of new design with a rotary bending action through a powerful ratchet operated screw. Completely portable, produces good quality bends speedily, accurately and with minimum of manual effort.

**CAPACITY:**  $\frac{1}{2}$ " to 2" dia. copper tube.  
 $\frac{1}{2}$ " to 1 $\frac{1}{2}$ " o.d. conduit.  
 $\frac{1}{2}$ " to 1" nom. bore gas and steam.

SEE OUR PERMANENT EXHIBITION AT THE  
BUILDING CENTRE OF IRELAND, DUBLIN.

FIRST  
MADE



FINEST  
MADE

For details of range of hand-operated, hydraulic and motorised machines handling up to 8" dia. tube, apply to local stockist or write to:—  
Dept. F. HILMOR LTD. (Sales and Service), CAXTON WAY, STEVENAGE, HERTS.

### “Freeze-up”

**I**F, after all this, someone somehow gets a “freeze-up” next winter, are you equipped to deal with it quickly and expeditiously, or do you still rely on the old blowlamp for thawing out?

Pipe defreezers earned their keep last winter, and no doubt will do so again. Electoria Ltd., of Whitchurch, Cardiff, introduced a new machine. Basically, it is a high resistance transformer passing a low voltage current of up to 500 amps. When a frozen pipeline is made part of the circuit to this current flow, the heating effect of the current warms the pipe and thaws the ice. The defreezer is provided with carrying handles but needs two men to carry it comfortably. Two 10ft. long leads of 3-core cable and 15 amp 3-pin socket are included for connection to domestic supply mains. Cable connections with convenient pipe clamp ends are sold as separate items so that customers can order to their own needs.

An ammeter is sensibly included to give visual indication of whether or not the house wiring is being overloaded. The makers suggest that with a reading of 12-15 amps. on the ammeter, the pipe should thaw out in about ten minutes—it takes almost as long to light a paraffin blowlamp.

### Time-saving

**I**T is very much a case of weighing its time-saving advantage against its capital cost before investing, but

Continued page nineteen

Seventeen

*The Irish Plumber and Heating Contractor.*

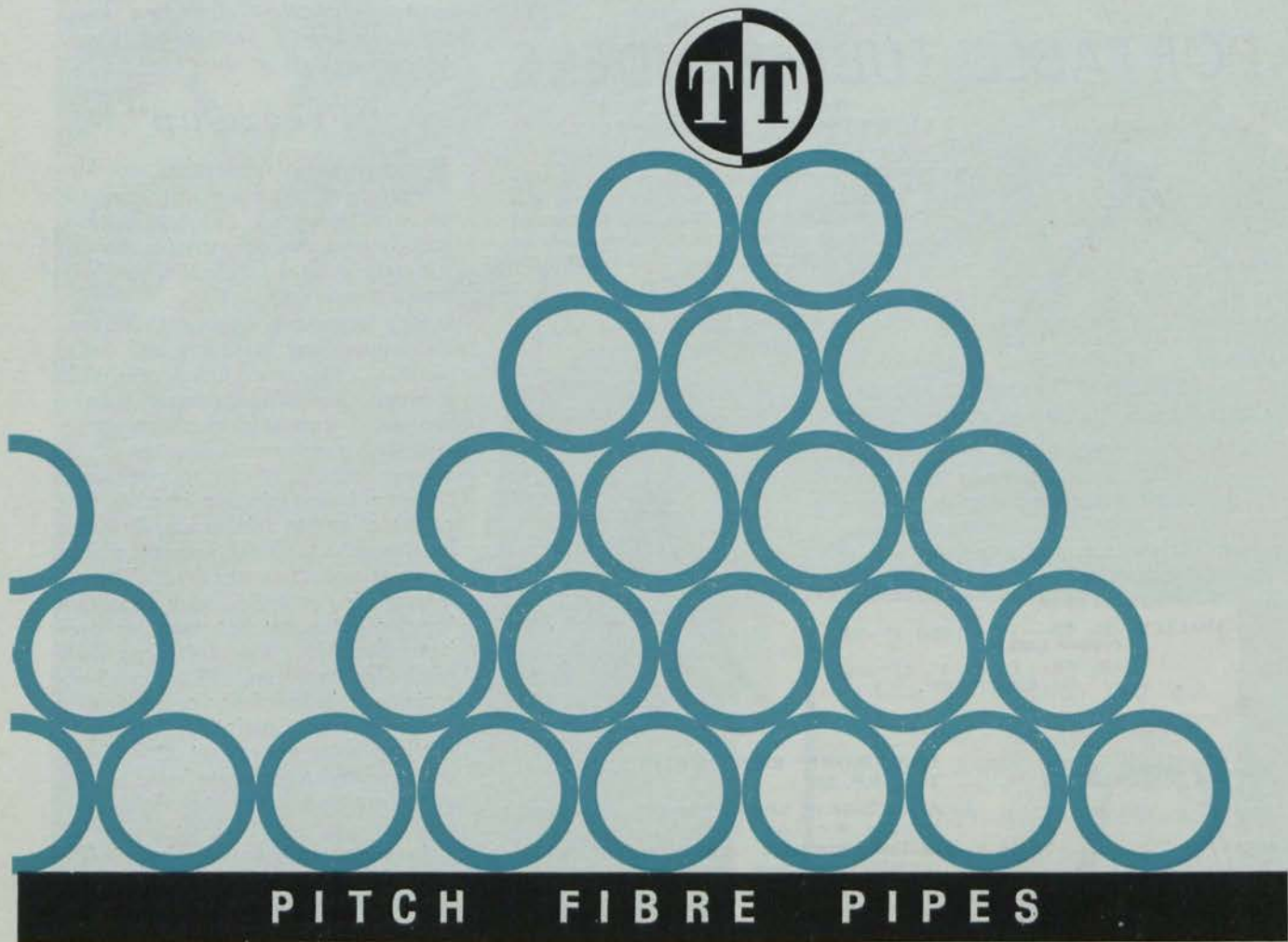

*Temple Tubes Limited Passfield Hampshire*

*Passfield 281 (5 lines)*



**We review here products from the leading manufacturers ranges. Claims made in the course of this review are, of course, those of the makers.**

**S**TEWARTS & LLOYDS of Ireland Ltd., East Wall Road, Dublin 3, announce that S. and L. high density polyethylene pipe, manufactured to B.S.3824, was awarded the British Standard Institute Kite Mark after passing the extra tests and inspection required for this renowned certification mark.

*From page seventeen*

generally, these machines are worth considering—but **before** the winter comes.

Plastic soil, waste and vent pipe fittings are becoming better known. Osma Plastics of Hayes, Middlesex, introduced a new range of P.V.C. fittings for this work. Available in seven metric sizes, the nominal equivalents being 1½, 1¾, 2, 3, 4, 5 and 6in., the push fit fittings are used with P.V.C. tube in 6ft., 8ft. or 10ft. lengths. These fittings are precision made by injection moulding and waste-gas tightness is assured by the rubber "O" ring, which is a feature of the joint which offers neat, and quick soft pipe assembly on site.

The high density of these pipes means higher tensile strength and, therefore, less material is used, giving a thinner wall, large bore, better rates of flow and reduced costs.

Steel tubes and fittings combine cheapness with strength, toughness, durability and freedom from corrosion in closed circuit systems. They are also conducive to silence in operation. Where steel or cast iron radiators and boilers are being used steel tubes and fittings are often preferred.

Hollow steel sections, B.S.4: Part 2. The recent publication of this new British Standard recognises that circular and rectangular hollow sections are being used increasingly by architects and structural engineers. Advantages of Hollow section construction are: (1) Strength with resistance; (2) speedy erection; (3) ease in handling; (4) reduced foundation costs; (5) clean appearance; (6) reduced surface of steel work, bringing savings in initial and periodic maintenance of up to 30%; (7) in marine structures or towers, lower surface area for water or wind resistance.

For many years alloy steel tubes

have been supplied to the oil, chemical and power industries. Because of technical advances in recent years the requirements of these industries have become more exacting and cover a wider range of services. This resulted in an increased demand for alloy steel tubes, the firm's long experience of manufacture, backed by the resources of their Research organisation, enables them to offer an exceptionally high grade product.

★ ★ ★

A. H. MASSER LTD., Annesley Works, East Wall Road, Dublin, represent J. S. & F. Folkard, Ltd., well known for their "Vulcathene" waste drainage system with Polyfusion joining process. The "Vultex" Laboratory shower and hospital fittings are also well known in the trade, while the demand for bunsen burners, furnaces and gas equipment of the Selas Gas and Engineering Co., Ltd., continues to grow.

★ ★ ★

EASE OF erection and the wide range of fittings available make Asbestos Cement soil and waste pipes a very economic and speedy method of construction. Details may be had from Asbestos Cement Ltd., 19 Lower Pembroke Street, Dublin.

*Continued overleaf*

## A. H. MASSER LTD.

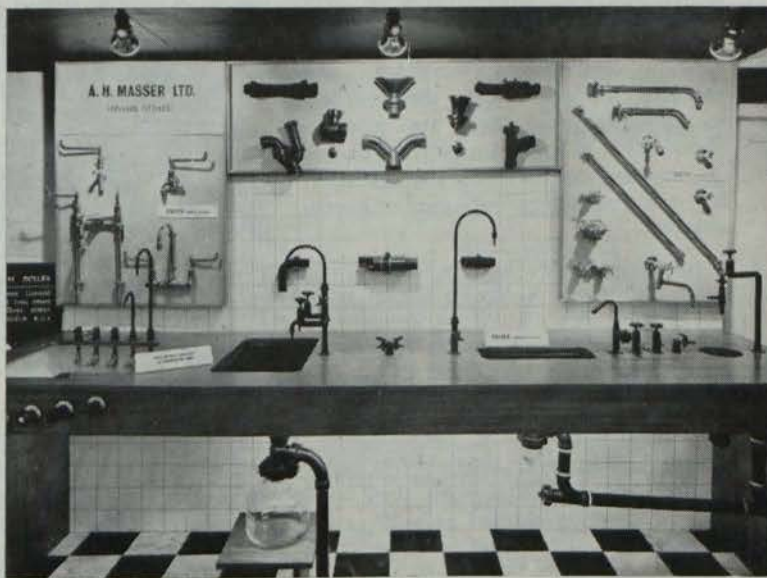

Visit our display at the Building Centre  
or write to

ANNESLEY WORKS, EAST WALL ROAD, DUBLIN 3  
PHONE 79801

REPRESENTING  
J. S. & F. Folkard Ltd.,  
"Vulcathene"  
Waste Drainage System  
with  
Polyfusion Joining Process

"Vultex" Laboratory,  
Shower and  
Hospital Fittings

Selas Gas and  
Engineering Co., Ltd.,  
Bunsen Burners,  
Furnaces and  
Gas Equipment.

# TRADE TOPICS

## Distribution of new range

**S**ANBRA FYFFE LIMITED report that distribution of their new range of Compression Couplings, known as the "Conex-Instantor," is well under way.

Features of this new fitting are the Conex ring and an instantor-type nut, so that the basic appearance has not undergone much change. To the user, however, comes the advantage of a neater range of couplings, the majority made from pressings rather than castings. To the firm's customers there is the advantage of merely having to stock one range as against two. The new range bears the Instantor numerical designation with the suffix "X", e.g. "310X".



This is the "New Victor" W.C. suite by Doulton Sanitary Potteries Ltd.

## DATE CHANGE

● This month The Irish Plumber and Heating Contractor switches to its new publication date—the twentieth of each month.

Twenty

## SPECIAL SURVEY

from previous page

TIME AND MONEY can be saved by using Temple tubes in eight feet lengths; by not having to use concrete protection; by making quick dry joints in any weather and conditions; by handling the material strong but light in weight and not subject to breakages, and by being able to pre-fabricate either at ground level or in the trench short awkward runs.

The resilient and flexible nature of Temple Tube allows for a degree of movement when subjected to pressures from unequal earth settlement or subsidence when rigid materials would crack.

The laying and testing of pitch fibre pipe can be completed the same day in any conditions—even when it's freezing. Neither frost nor saturated ground halts the progress of laying, and in completely waterlogged conditions the pipe can even be used to drain a trench.

Pitch fibre conduits are being used in Britain on a large scale and have been for more than fifty years wherever electric cables require protection. Temple Fibre conduits are manufactured from the same quality of pipe that satisfies British Standard 2760/56 for drainage use. They are normally supplied in eight feet lengths with either spigot or socket, or sleeve joints, and with either heavy or light wall thickness.

Manufactured from cellulose and asbestos fibres under the strictest scientific control, they are impregnated with a special pitch to ensure an impervious material that is ideal for the protection of cables everywhere.

Irish agents: North Down Equipment Co., Ltd., Dublin Road, Belfast.

★ ★ ★

THE WICU Tube, the ready-made heat-insulated copper tube, can be used for hot- and cold-water supply, heating supply and return flow, fuel oil, city and liquid gas as well as for measuring and control systems. In all of these fields Wicu tube has been a success in recent years. Also, for moderning old buildings which are increasingly faced with the competition of new building constructions,

Wicu tube is being used. Wicu tube combines the merits of copper and the latest scientific achievements of the modern synthetic industry. It is produced from oxygen-free copper of high purity and a plastic compound of plasticized, stabilized PVC (polyvinyl-chloride).

The Wicu thermo tube is now available in the  $\frac{3}{4}$ " size as well as the  $\frac{1}{2}$ ".

Irish agent: L. R. Wood, Ltd., 174/5 Pearse Street, Dublin 2.

★ ★ ★

SETFLO radiator valves and fittings for small bore central heating, a product of Sanbra Fylfe, Ltd., Dublin, are efficient, unobtrusive and cheap to install.

The firm's up-to-date range of plumbers' brass ware can be seen at your stockists. All patterns can be supplied—polished or chromium painted.

The Company's valves and fittings for copper tubing are also available. They are equally reliable for use with plastic pipes.

The Conexcel fittings and adaptors are also popular in the trade.

★ ★ ★

"PUSH-FIT" couplers, repair sleeves and "push-fit" flanged adaptors are now being supplied by Unidare Ltd. for use with their hard P.V.C. watermains. These are being precision manufactured in cast iron in their own foundry at Finglas and the one standard range of fittings is used for pipe to class the B, C or D.

Within recent months Unidare Ltd. also extended their range to include High Density Polythene Tubing to B.S. 3284: 1961 Table 1, in addition to their existing High Density Polythene Tubing to B.S. 3284: 1961 Table 2, and popular Hydrodare Low Density Polythene Tubing to B.S. 1972.

★ ★ ★

WAVIN PIPES LTD., who only last year moved to new, larger factory premises at Balbriggan, produce a pipe that is non-corrosive, immune to all chemical attacks. They are light, inexpensive and easy to install. Wavin hard P.V.C. piping is versatile and is enjoying wide application in both indoor and outdoor contracts.

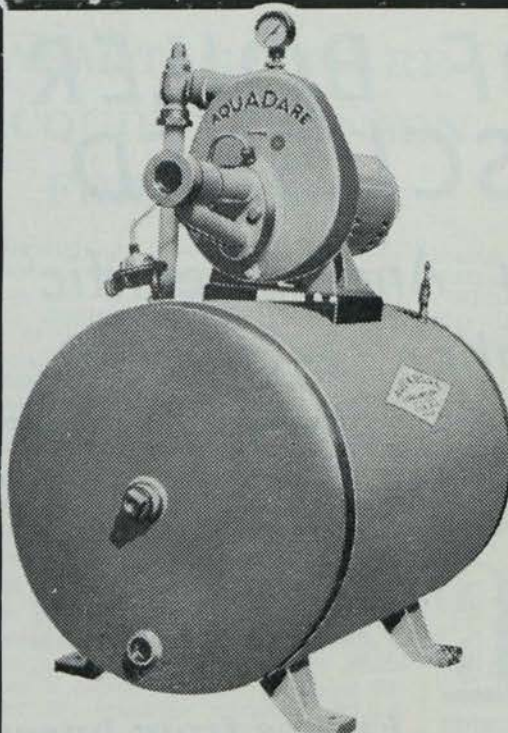
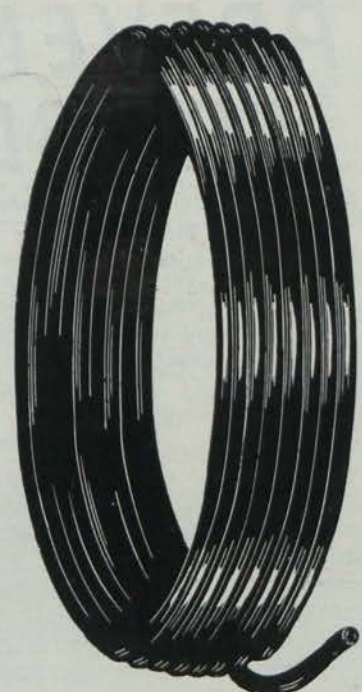
 <p>A large industrial pump with a cylindrical body and a top-mounted motor assembly. The word 'AQUADARE' is visible on the top assembly.</p>	<p style="text-align: center;">★</p> <p style="text-align: center;"><b>Extensively advertised</b></p> <p style="text-align: center;">★</p> <p style="text-align: center;"><b>Recommended by all leading merchants</b></p> <p><b>AQUADARE PUMPS</b> Extensive range: depths to 160 feet and engine driven models. After Sales Service.</p> <p><b>HYDRODARE TUBING</b> Low density or high density polythene and PVC water mains by Ireland's pioneer manufacturers of plastic pipes.</p>	 <p>A large coil of dark, flexible plastic tubing, likely polythene or PVC, shown in a circular arrangement.</p>
--	---	---



# UNIDARE LIMITED

UNIDARE WORKS, FINGLAS, DUBLIN 11.

Ratchet housing :  
with 2 large ratchets easy to operate thanks to big knurled knobs  
Die heads :  
with 8 point drive for maximum force and long wear. Large holes for easier removal of chips and cutting oil application. Cover plate clamped on die head with counter-sunk screws assures accurate die positions and cutting

## TOOLS WELL ADAPTED TO YOUR JOB

For you, in England, as well as throughout the world, VIRAX proposes a complete range of strong tools making use of the latest techniques.

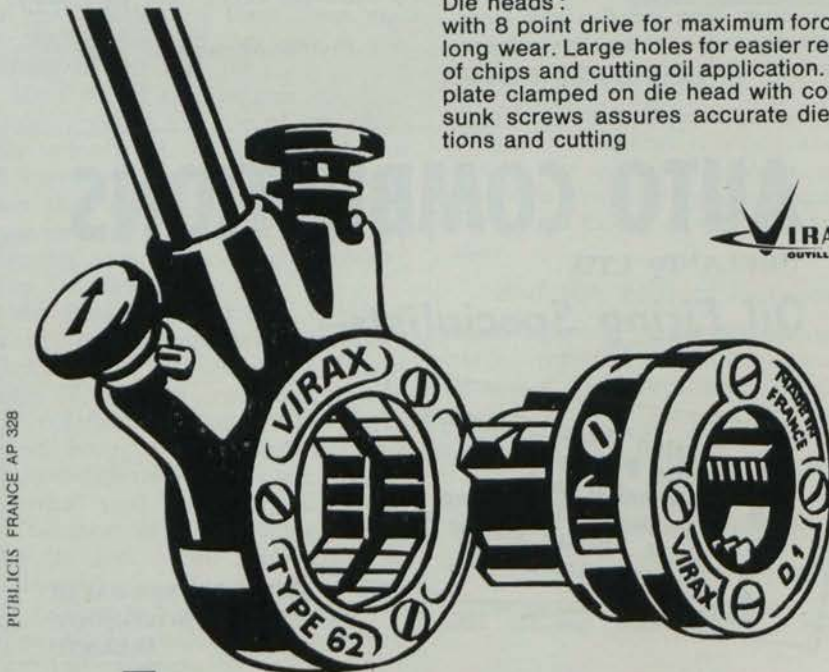

PUBLICIS FRANCE AP 328

# virax

Messrs. J.S. LISTER  
Dorset Row  
DUBLIN - Tel : 47881

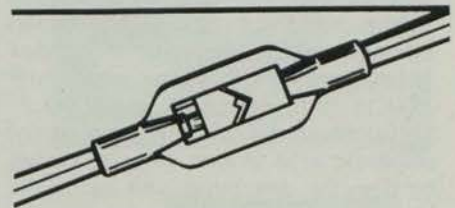

Adjustable tap wrench

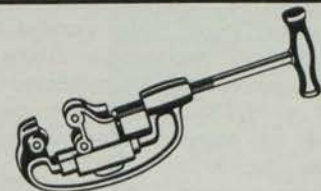

VR 2 pipe cutter

**QUALITY AT THE SERVICE OF ALL INDUSTRIES.**

Twenty-one



The Irish Plumber and Heating Contractor.

# PREVENTION OF BOILER PROBLEMS DISCUSSED

**M**ORE than 200 people attended a meeting of the Engineering and Scientific Association of Ireland in the Physics Lecture Theatre, Trinity College, Dublin, when Mr. G. T. Peat, B.Sc., F.R.I.C., presented a paper entitled, "The cause and prevention of some of the problems encountered on the water and fire side of boiler plant."

Trouble on the combustion side of boiler plant is usually due to either deposit build up or corrosion of the metal, and in both cases it is the element sulphur which is mainly responsible, said Mr. Peat.

The problems encountered with solid fuel burning are somewhat different from those of liquid oil fuel. Let us then consider coal, he said.

Trouble on the fire side of industrial plant boilers is invariably due to build up of deposit rather than corrosion, but this is due to the fact that the percentage of sulphur in coal is considered high when it exceeds 1.8% whereas it is quite common to encounter 4% or over in high viscosity residual fuel oils.

## Sulphur dioxide

**W**HEN fuel burns the sulphur combines with oxygen to form sulphur dioxide  $S + O_2 = SO_2$ . However, a portion of the sulphur, according to the amount of free air in the flue gases, is further oxidised to sulphur trioxide  $SO_3$  (up to 5%) and it is the presence of  $SO_3$  which causes corrosion of ferrous metal at the dew point, because  $SO_3$  unites with water  $H_2O$  to form sulphuric acid  $H_2SO_4$ .

Unfortunately, as the amount of sulphuric acid in flue gases increases, so does the dew point, and again, the higher the amount of water vapour present in the flue gases, the higher is the dew point. For example, the dew point of a flue gas containing 0.001% by volume of sulphuric acid varies as follows according to the amount of water vapour present in the flue gas:—

Water Vapour	Dew Point
5.1%	180°F
8.5%	196°F
25.2%	212°F

## Engineering And Scientific Association Lecture

The dew point temperature keeps on increasing and at a concentration of 0.01% sulphuric acid with a water vapour content of 25.2% the dew point of the flue gas is as high as 351°F.

### Dew point

**I**T is interesting to note that as the amount of water vapour increases so does the dew point, because when oil burns one gallon of oil produces almost 1-gallon of water. This is due to the fact that fuel oil is a hydrocarbon, i.e., a linkage of carbon and hydrogen atoms, and as it burns the carbon unites with oxygen to form carbon dioxide and the hydrogen unites with oxygen to form water.

Coal, on the other hand, is mainly carbon. Thus the flue gas from coal is dryer than the flue gas from oil, and as coal contains less sulphur than oil, so the amount of corrosion

on the combustion side is invariably less with coal than with oil.

However, corrosion can be encountered on the combustion side of coal burning boilers, particularly in plants using a fuel of high sulphur content and where air heaters are installed where the temperature of the flue gases can be reduced to below 230°F.

### Fumes from buses

**M**R. John Tighe proposed a vote of thanks to Mr. Peat.

Mr. Vincent McLoughlin seconded this vote and while thanking the speaker for an excellent paper, remarked that while he knew nothing about the use of fuel oil additives for industrial boilers he had never seen any beneficial result from their use in

*Continued opposite page*

## AUTO COMBUSTIONS

(IRELAND) LTD.

Oil Firing Specialists—

- Clayton Steam Generators
- Wade Pumps
- Swirlmiser and Autoflame Oil Burners
- A.C.L. Boiler Burner Units
- Hot Air Units

FULL AFTER-SALES SERVICE THROUGHOUT IRELAND

144 Lr. Baggot Street, Dublin

Phone

66338

# ARMITAGE WARE ACQUIRE JOHNSON FIRECLAY CO.

**TRADE**

**TOPICS**

Negotiations have now been completed for the acquisition by Armitage Ware Ltd., of the Johnson Fireclay Co. Ltd., Excelsior Works, Stoke-on-Trent, one of the leading makers of sanitary fireclay ware, established in 1912.

Manufactured under the brand 'Excelsior Ware', the modern range of products includes kitchen sinks, ablution fixtures, stall urinals, and a wide number of types specially produced for hospitals, laboratories, public institutions, hotels, factories, schools, and buildings requiring strong durable fixtures for extra heavy duty.

The combined resources and organisation of the two companies, together with the manufacturing facilities of the Armitage Brass Factory, will provide a complete service, embracing the whole range of sanitaryware or plumbing fixtures in Armitage vitreous china.

Excelsior fireclay and Armitage metal fittings.

With the retirement of Arthur Guant, who has been chairman of Johnson Fireclay Co. Ltd., for a great many years, the new Board of directors will comprise: C. Kenneth Stott and Alan E. Stott, chairman and joint managing directors of Armitage Ware Ltd., and K. Campbell as company secretary, with D.

Shaw, S. Langford and R. Scott, who are active members of the present Board.

The Johnson Fireclay Co. Ltd. will operate as a separate unit, under its present title, and the long-established trade policy, traditions and existing sales arrangements will continue.

● Full details of next month's Special Directory issue are given on page eight. Additional copies may be ordered in advance of publication on application to: The Irish Plumber and Heating Contractor, 13-15 Dame Street, Dublin.

from previous page

## Lecture

motor vehicles and declared that smoke fumes, etc., that issued from the heavy buses and lorries was due to bad operation of these buses, etc., by the drivers and not due to any defects of the fuel oil.

Members of the various oil companies opposed the use of oil additives strongly on the grounds that if additives were necessary or beneficial then the oil companies, with their huge research laboratories and staff of chemists, would have recommended their use long ago.

Mr. Peat remarked that it was a strange coincidence that while every other type of oil, i.e., petrol, lubricating oil, etc., all contained at least five different additives, fuel oil contained none. Fuel oil was the only oil in competition with some other fuel—i.e., coal, turf, and of course, the addition of an additive would raise the cost of the fuel oil. The oil companies could not afford this rise as even a slight rise of 1d. per gallon would make oil dearer than either turf or coal.

The cost of Pyralgor represents 0.9% of the cost of the fuel oil and we would expect a saving of at least 4% in the fuel oil consumption.

A reception followed at the United Services Club.

at

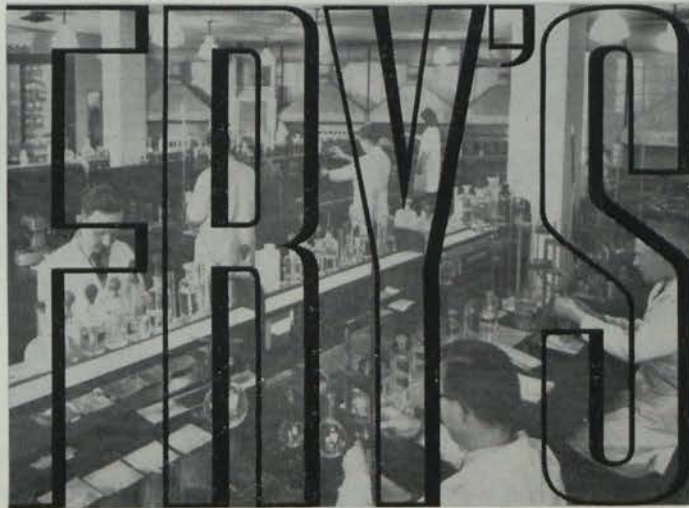

### modern laboratories

Up-to-date and modern in equipment. Staffed by expert analytical chemists and research workers who carry out thousands of scientific tests each year on products associated with Solders and Fluxes, as they pass through the works.

... and this kind of instrument ...

which makes use of the characteristic decomposition potential of metal to determine the amount of an element present in the alloy.

Precise instruments like this one, used in modern laboratories, enable Fry's to ...



guarantee you fast, effective soldering whatever the job.

**FRY'S** set the pace

by using science in quality control.

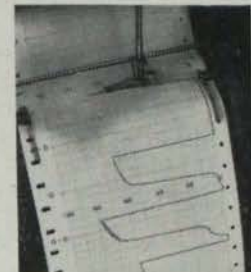

Fry's Metal Foundries Ltd., 197 Pearse St., Dublin.

Telephone: Dublin 74243.

LONDON, MANCHESTER, KIDDERMINSTER and GLASGOW.  
MR/63/2

*The Irish Plumber and Heating Contractor.*

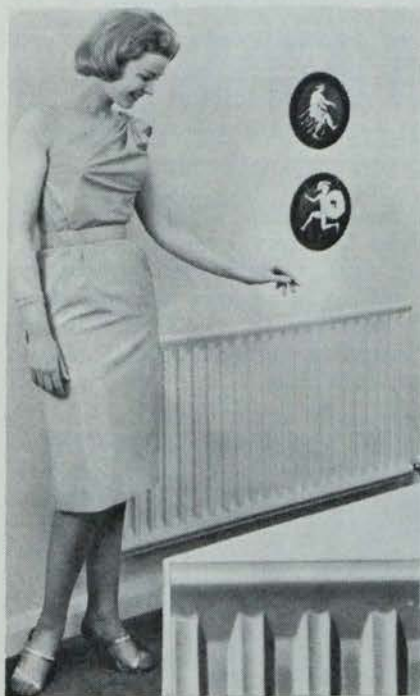

Pictured here is an installation of the new "Corinthian" radiator. Inset shows detail of attractive fluted columns.

A NEW radiator with classical lines is announced by Copperad Ltd. Titled "The Corinthian," the Copperad radiator has been styled to blend with both domestic and industrial situations.

The units are slim, just over 1" maximum depth for the single panel and a little over 3" for the double, and die formed from high quality steel. A particular feature is the smoothly curved seamless top. It is also claimed that the attractive fluted columns provide a sturdy surface, easily cleaned and resistant to shock or abuse. A particular point of note is the fact that the wall fixing brackets, an air vent and plain plug are supplied without extra charge.

For high duties, double panel radiators are available or alternatively the single panel units are extendable by connecting end to end with special union joints. Unobtrusive cover strips which are formed to match the fluted radiator ribs, clip on, and so make the units appear as one.

In order to eliminate damage in transit and easy identification on site, each radiator is individually packed in a purpose made container complete with its wall brackets. The carton has been designed to be left on the site if desired until after fixing up

## TRADE

## TOPICS

and ready for final decoration.

The units are available in three standard heights—18", 24", and 30". Each of the heights is available in eight standard lengths, 16", 24", 32", 40", 48", 56", 64" and 72". Every radiator is tested to 100 psig air pressure under water before despatch and is suitable for a normal working pressure of 50 psig.

Further details from British Steam Specialties Ltd., 33 Leeson Park, Dublin, and, in Northern Ireland from Mr. K. R. Morrow, Copperad Ltd., 7 Beechill Park, South, Saintfield Road, Belfast 8.

### Cape Asbestos Group results

THE NET profit of The Cape Asbestos Group of Companies in 1962, after deducting all charges except taxation, amounted to £1,283,793, compared with £1,702,619 in 1961. This was announced by the Chairman, Mr. R. H. Dent, in the Group's annual report and accounts.

The Board recommended a final Ordinary Dividend of 12½% in respect of the year ended December 31, 1962, making, with the Interim Dividend of 5% a total Ordinary Dividend of 17½%. This compares with a total Ordinary Dividend of 22½% for the year 1961. In addition, the Board is recommending the payment of a bonus of 2½% on the Ordinary Shares.

### HAMMOND LANE'S FURTHER PROGRESS

HAMMOND LANE INDUSTRIES LTD. have been making striking headway in their Catering Equipment Division.

In a comparatively short period they have developed the following range of equipment:—

Plain Top and Bain Marie Hotcupboards in standard sizes from 2 ft. to 10ft.

Servery Counters for Hospitals and Restaurants.

Self-Service Counters.

Back Bar Equipment and Called Order Units for gas, and electric heating.

A wide range of Mini-Hotcupboards and Counter Bain Maries is available for the smaller caterer and is specially suitable for snack bars and licensed premises.

### NEW COMPANY

A NEW company recently registered is that of Austin Drumm (Plumbing and Heating) Ltd. (Private Company). Registered Office—Not stated (Northern Ireland). Nominal Capital—£2,000 divided into 40,000 shares of 1/- each. Objects—To acquire, establish, carry on and develop in all or any of the company's branches, the trade or business of plumbers and heating engineers, electrical and mechanical engineers, plumbers' and builders' merchants and suppliers, etc.

Names and descriptions of Subscribers to Memorandum and Articles of Association (Subscribers of One Share each)—Austin Drumm, plumbing and heating contractor, 9 Slievegallion Drive, Andersonstown, Belfast; Trevor Ingram Allen, solicitor, 50 Upper Arthur Street, Belfast.

The names of the First Directors are not stated.

### SANITATION IN GARAGES AND PUBS SHOULD BE PART OF THE SERVICE

"GOOD lavatories are good business" was the recurring theme of a paper read in London under the auspices of the Royal Institute of Public Health and Hygiene. The speaker was Major W. E. Gurry, a member of the Council of British Sanitary Pottery Manufacturers, who was giving the third in the current series of lectures on sanitary standards in Britain to-day.

Major Gurry urged the motoring organisations to include standards of sanitary accommodation when classifying hotels. Otherwise their stars and other symbols were uninformative. It was, moreover, a ridiculous legal anomaly that staff in restaurants and cafes should have to be given decent accommodation, but the comfort of the poor old customer was disregarded.

"Yet if it were known that every pub selling so-and-so's beer along the main roads of our country had a reliably high standard of sanitary accommodation, I for one—especially if I were travelling with my wife—should be glad to know and use such provision," he said.

the  
author

**John G. Bolton**

Lecturer in Plumbing and Heating at the College of Technology, Bolton Street, Dublin.

# ELECTROLYTIC ACTION ON PIPELINES

AS described last month, electrolytic action can easily occur between two different metals if they should come in contact in the presence of moisture. This fact is well known to most of us in the trade and gives emphasis to the importance of not mixing our metals indiscriminately.

What is, however, not so well known, is the fact that this action may occur even if there is only one metal present. Here, the basis of action depends principally on the "electrolyte"—in other words, on the soil or water surrounding the metal. Hence we must look to these factors as the explanation for the failure of many an underground pipeline.

It is usual in scientific circles to classify electrolysis under two main headings—Stray Electrical Leakage Corrosion, and secondly, Galvanic Corrosion from the soil or water through which the pipeline passes.

## Complex grid

IN present day circumstances, where we have the roadways and pathways of our cities covering a complex grid of electrical cables and also a multitude of water and gas pipelines, it does not need much imagination to realise that should stray currents leak from the cables, they may short circuit to the nearest pipe and travel along it for some distance before shorting again to a different pipeline or other conducting material with a lesser resistance. The point where the current enters the pipe will then become the cathodic area, and the departure point the anodic or corrosion area. This type of corrosion is sometimes very rapid in action and the pipeline becomes quickly perforated at the anodic area.

In the old days of tramway systems,

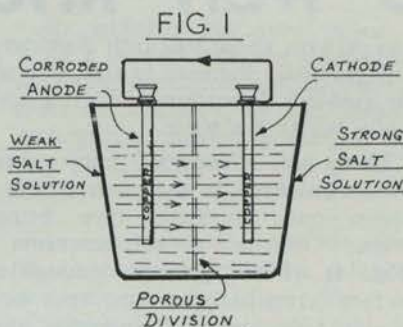

with their D.C. supply, very heavy current leakage would sometimes pass, via the tracks, into the nearest metal water main and eventually back to the power station through another point of outlet.

However, we in this country no longer have this problem to face up to, since our last remaining tramway to the Hill of Howth (near Dublin) fell a victim to progress.

In this context of stray electrical leakage we must not forget our friend the electrician with his predilection for our water pipes to provide him with an earth path. Should a leakage

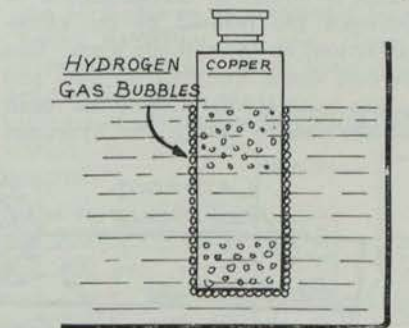

POLARISATION OF A VOLTAIC CELL

FIG. 2

occur from faulty electrical equipment, then it will travel to earth via the pipe and the resultant point of exit in the ground becomes a focus for rapid and severe corrosion.

This is particularly so where a plastics pipe runs in from the main, and is continued into the house in copper. This "set up" provides the ideal conditions for corrosion at the point in the ground where the copper ends and the plastics begin. Similar conditions would exist on plastics and asbestos mains where the ferrule provides the point of exit should copper or other metal service pipes be used. In such circumstances, electrical apparatus should not be earthed to the pipe.

## Underground galvanic attack

THIS form of single metal corrosion is very widely met with and deserves our special attention. Here we get cell or "noodle" formation due to changes in the make up of the earth or water through which the pipe passes so that a potential difference may develop between one portion of the soil or water covering and another.

This action can be demonstrated by a glass jar with a porous division dividing it into two sections (Fig. 1) so that a concentrated solution and a dilute solution of salt can be poured respectively. If now two strips of the same metal are immersed in the solutions and connected externally by a wire conductor, a current will begin to flow, with the metal in the dilute solution forming the anode and thereby becoming corroded away.

Specimens of this class of corrosion

*Continued overleaf*

*The Irish Plumber and Heating Contractor.*

can be seen in cases where a pipeline passes through marshy salt-laden soil or through ground where agricultural fertilisers have been spread, so perhaps giving a high concentration of chemicals in one portion of the soil when compared with another, thereby giving rise to a difference in electrical potential which is the basis of all electrolytic action.

This electrolytic effect can also occur through difference in the oxygen content of the soil. This can happen

*from previous page*

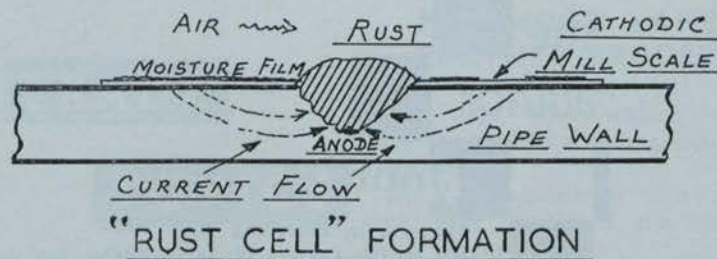

FIG. 3

# A not so well known fact

where we have variation in the compactness of the earth surrounding the pipeline. Where the soil is well compressed around the pipe it will become the anode part of the current flow or electrolyte, whereas the lightly filled soil will form the cathodic part of the circuit. To many of us, it will perhaps be news that the filling in of the trench surrounding a metal pipe will have a considerable bearing on its future life.

## Minute currents

WE are all familiar with the large "noodles" of rust which form after some time inside the shell of a cast-iron W.C. cistern. This type of corrosion is again galvanic in origin and is due to minute currents set up and accelerated by oxygenation from the filling and emptying of the cistern. It is evident from the extent of the rusted area that very severe attack takes place due mainly to the fact that the cathodic area is large, whereas that of the anode is small, so leading to a concentrated current flow.

Another name given to this type of corrosion is "cell formation" (Fig. 3), and its origin can be traced to dozens of different prime causes—for instance, even the mill scale oxide normally present on the outside of a mild steel tube has been known to provide ideal conditions for corrosion due to a break in its continuity. Here, the scale becomes the basis for the rust cell and is the cathode, with the steel pipe the anode. This rust cell begins to increase in size, and the resultant cracks in it create ideal conditions for accelerated attack to take place. Many readers will, no doubt, be familiar with the gradual rusting of an iron bolt set in stonework. Here, the bolt, which in its original state

was perhaps about half-inch diameter, will gradually increase in size, due to the rust-cell formation, until it eventually bursts the stone.

There are, of course, many other factors involved in the onset of corrosion—one prevalent type being termed "crevice or pit corrosion" (Fig. 4). Here, perhaps, through a surface irregularity, a rust spot begins to form and as it increases, the spearhead or point of attack into the pipe no longer gets oxygen from the external air due to its depth of penetration, whereas the external surface is constantly replenished with fresh oxygen, thereby resulting in a cathode area, with an anode forming at the crevice pit.

## Hydrogen gas

THIS electro-chemical corrosion will continue with increasing effect, unless it is neutralised by what is called "polarisation of the cell" (Fig. 2).

This is due to an accumulation of hydrogen gas (caused by the chemical action) on the cathode area. This gas cuts down the electron flow and so acts as an insulator, with the result that the rate at which the hydrogen

ions reach the cathode is much reduced or stifled, with a consequent stoppage of the rusting action on the pipe.

Unfortunately, this hydrogen bubble insulator can be removed by oxygen absorbed from the surrounding air. What happens is that the oxygen units chemically with the hydrogen, forming water, and so the rusting recommences. This polarisation action can be demonstrated very easily by connecting an electric bell with a voltaic cell. At first, the bell will ring loudly, but gradually the sound begins to decrease until finally the bell can barely be heard. Then, if the cell is shaken to dislodge the hydrogen gas bubbles on the plate, the bell sounds loudly again.

Another cause of pipeline corrosion, and one which is the subject of much investigation at the moment, is that caused by the depolarisation of inert rust cells by bacterial action. In most soils will be found bacteria, but in heavy, damp, oxygen deficient clay soil, where favourable conditions are produced by the presence of sulphates and traces of iron, a type of anaerobic (oxygen hating) bacteria will be found to exist.

*Continued opposite page*

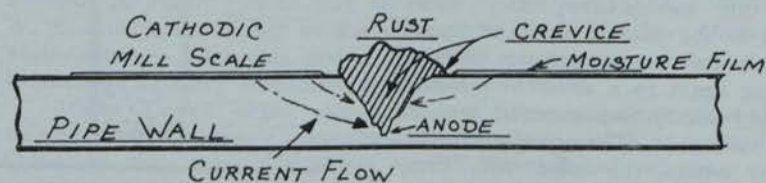

"CREVICE OR PIT" CORROSION

FIG. 4

## NEW APPROACH TO PUBLIC CONVENIENCE DESIGN NEEDED

"WHEN WE surround ourselves with decent conditions, as for instance in our living room, we naturally treat them decently. Apart from any other

inhibitions, living rooms are light, airy, attractive places. So should public conveniences be."

from previous page

### More impetus

**T**HESE organisms—called sulphate reducing bacteria—while not of themselves being the prime cause of corrosion, will however add impetus to the rusting effect, which originally may be only of small proportion. The bacteria use the hydrogen bubbles on the cathodic area of the pipe to transform soil sulphates to sulphides which then attack the metal pipe. One of the indications of this action is the producing of a black sulphide crust at the corrosion area. In many cases this is accompanied by a smell of bad eggs—sulphureted hydrogen.

There also exists a type of bacteria known as aerobic or iron bacteria, which due to its affinity for oxygen will cause oxidation and so form ferric iron. The action here is mainly the acceleration of the corrosion or reduction of the metal pipe.

In addition to these fore-mentioned soil organisms, we have many others, such as the cellulose-reducing type which specialise in attacking the protective wrappings on steel pipes, so exposing the metal to the full corrosive action of the surrounding soil.

Again, in connection with cast-iron water mains, we have all met the case where the main has, in parts, turned into a black spongy condition, easily penetrated with a sharp point.

This action is called "graphitisation" and is due to flakes of graphite being present in the cast-iron. These are resistant to corrosion, but, in turn, cause the surrounding metallic iron to receive the full corrosive attack.

### NEXT MONTH

[In our next issue, we will consider methods of corrosion prevention from the dangers of electrolytic action, and will take a look at some forms of cathodic protection.]

### NEXT MONTH

This view was expressed by Mr. E. A. Batchelor, Chairman of the Council of British Sanitary Pottery Manufacturers, in a lecture in the Mansion House, London. It was the first of a series of five on sanitary conditions in Britain being presented this Spring by the Royal Institute of Public Health and Hygiene.

He added: "Yet even when we build a modern one, we plant shrubs all round it to shut out all the light from the windows, or else shove it underground down a grovelling stairway. Evidently when we go to the lavatory we are not at home."

He concluded his lecture with a plea to eliminate vandalism. It could be done, and it should be. The secret of success was to provide first-class conditions; that would do as much as anything to eliminate dirty habits. It should never be forgotten that the health of the nation depended in no small measure upon the success of such an operation.

## New Hattersley valve range

HATTERSLEY (ORMSKIRK) Ltd. will be showing for the first time, at the forthcoming International Engineering Exhibition, a new range of valves sharing the same basic design but having the advantages of alternative seating designs and materials.

The valves are Class 200 (200 p.s.i./500°F and 400 p.s.i. w.o.g.) and Class 300 (300 p.s.i./500°F and 600 p.s.i. w.o.g.) in screwed end patterns and 100 p.s.i., 150 p.s.i., and 250 p.s.i. in the flanged patterns, with B.S.T. "E," "F," and "H" flanges, respectively.

## TRADE

## TOPICS

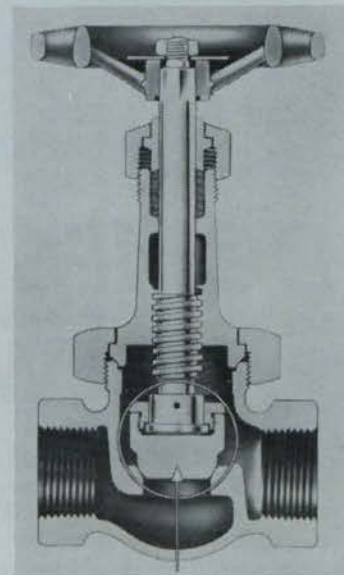

There are four interchangeable seatings for the new Hattersley Globe and Check valves.

Four types of seat design are available, making the valves suitable for all industrial applications up to 300 p.s.i. and 500°F. The types are (a) renewable moulded asbestos disk and nickel alloy seat (b) Bronze disk with ball/cone integral seat (c) Nickel alloy semi plug disk and seat, and (d) "Pre-seater" protected seat valve with a stainless steel disk and seat.

The design is robust and all seats can be ground in the line, making for easy maintenance. All valves are hydrostatically and air under-water seat tested.

Irish agent: W. H. Leech, Esq., 414 Ravenhill Road, Belfast, 6.



"If the water pressure should drop again, let me know."

*The Irish Plumber and Heating Contractor.*

**A. L. TOWNSEND**  
M.R.P., M.R.S.H.

The author, a lecturer at Oxford College of Technology, continues the first part of a four stage course on plumbing.

## DOMESTIC WATER SUPPLY: PIPEWORK JOINTS (Cont.)

**BLOWLAMPS** used for joining copper commonly burn paraffin. Some, however, use petrol, and although all blowlamps must be used with great care, these should be treated with extra special caution. Be very careful not to become so interested in the actual job of jointing that you put the lamp down where its flames can play on the woodwork of doors, skirtings, or furniture.

Butane Blowlamps burn a liquid fuel which gasifies and burns at atmospheric pressure. The fuel is stored in special replaceable "bottles" on to which the burner of the lamp is screwed so that it looks very like an ordinary paraffin blowlamp.

The advantages of this newer type of blowlamp are first, that it is economical. It needs no pre-heating; a turn of the gas valve allows gas to flow to the burner where it ignites the moment a flame is applied. The second advantage is that it is safe. As soon as a joint is complete, a turn of the gas valve shuts off the lamp, saving fuel and avoiding any risk of starting a fire.

### Steel tubes

**MILD** Steel tubes are jointed by fittings which are screwed tightly on to screw threads provided on the pipe ends. The threads are standard in pattern and number of threads per inch, and the fittings are threaded to the same British Standard Pipe Thread (B.S.P.T. as B.S.21) to ensure that fittings of different kinds, and made by different firms, are interchangeable.

Pipe threads are cut on to the pipe ends with special thread-cutting tools called stocks and dies. There are usually four dies, housed in the adjustable die stocks, and these are the actual cutting tools. The stocks also house the adjusting mechanism, and have long handles which provide the leverage necessary to work the dies round the pipe, so that they cut the thread.

The joint is formed as follows. A fitting is tried on the screwed pipe end to check that the threads are correctly cut and that they are engaging properly with the fitting. Jointing compound is then applied to the thread on the pipe, and strands of hemp are carefully wound into the threads. As the fitting is finally screwed home, the hemp is ground and compressed between the screw threads of the pipe and fitting so that a watertight joint is made.

### Plastic tape

**ALTERNATIVELY**, a specially prepared plastic tape may be used in place of jointing compound and hemp. This tape, made of one of the polythene group of plastics, is  $\frac{1}{2}$  in. wide and supplied in 40-foot reels. It is simple, quick and clean to use. Sufficient tape to pass round the circumference of the pipe thread, with about  $\frac{1}{2}$ " for overlap, is torn off the reel. One end of the tape is held on the thread while the free end is wound tightly round so that it takes up the shape of the threads. The  $\frac{1}{2}$ " overlap secures the tape in place by

sticking to the tape below. When the fitting is screwed home, the tape, locked between the pipe and fitting threads, automatically and positively seals the joint.

The plastic tap jointing material is suitable for virtually all screw threaded joints in any material. It is resistant to corrosion, self-lubricating, and it never hardens. Joints made with it can be tighter because of its lubricating property, and the ease with which joints can be undone even after long periods of time is a great advantage in maintenance and repair work.

Normally, the dies cut a tapered thread on the pipe end, and the parallel threaded end of the fitting is liable to stretch as it tightens on the tapered pipe thread.

Over tightened malleable cast iron fittings may stretch beyond their limit and split. This might be noticed because it would suddenly become easier to turn the fitting with the pipe wrench. On the other hand, it might go unnoticed until the pipe were filled with water and a leak showed the split.

### Polythene tube

**COPPER** tube compression fittings can be adapted for polythene tubes. This has been a very common practice and will no doubt continue, but considerable thought has been given to the development of joints designed to suit the particular qualities of the plastic tubes which are now becoming available.

Joints for plastic tubes will be more

*Continued page thirty-three*

**THOSE WHO  
SPECIFY IT...**



**THE ARCHITECT** with an eye for efficiency also sees in the Lynx's clean-cut lines contemporary styling at its very best.

**THOSE WHO  
INSTALL IT...**



**THE PLUMBER** finds it easiest of all to fit; the concealed fixing is neat and simple.

**THOSE WHO  
OWN IT...**



**THE CUSTOMER** is delighted to discover that such a handsome cistern also has the most discreetly quiet and dependable mechanism she's ever encountered.

**...All acclaim the**

*Shires*

**LYNX**

**MADE IN IRELAND**

Shires Lynx is today's most popular cistern, for replacements or new installations. Lynx high and low level cisterns are made of black Duranite — tough and durable, non-crazing, non-corrosive. The Kingfisher syphon mechanism gives a powerful flush: made of polythene — non-corrosive, non-ageing and unbreakable — it can be used in hard or soft water areas. It conforms to BSS 1125 and Water Works specifications. Capacities: 2, 2½ and 3 gallons.

**EVERY GENUINE LYNX HAS THE NAME ENGRAVED ON THE CISTERN**

Other Shires' products are the Uni-Lynx close-coupled suite, cistern fittings and the Polyfloat cold water cistern float.

Available from all recognised builders' providers in the Republic

**SHIRES (IRELAND) LIMITED, STANNAWAY DRIVE, CRUMLIN, DUBLIN**

Published by ARROW@TU Dublin, 1963

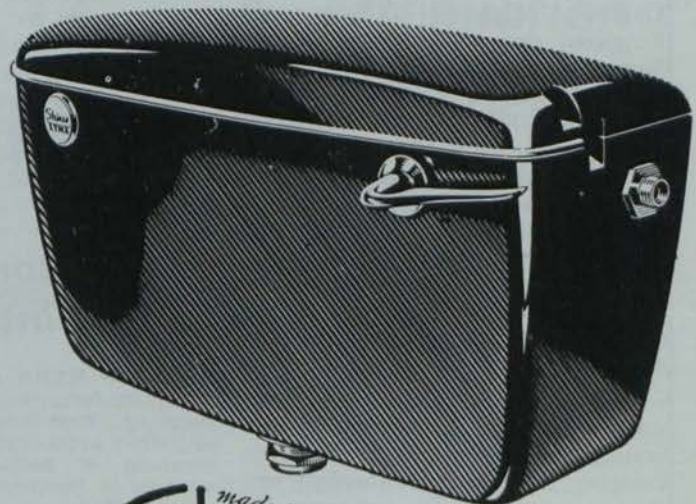

*made by*  
**Shires**  
*for your convenience*



*The Irish Plumber and Heating Contractor.*

**NORTHERN**  
FROM  
**ALLEN McDOWELL**  
**NOTES**

**Belfast firm open  
a Dublin branch**

**H**HEATING Controls and Devices, Ltd., 227 Beersbridge Road, Belfast, 5, announce that they have appointed Mr. J. M. Hackett, who was previously with John R. Taylor, Ltd., as their branch manager in Dublin. Their Dublin offices are at 6, Mount Street Crescent.

Mr. Hackett, who is well known in the heating and electrical trades, especially in the Leinster area, spent three years in Toronto with Avro Aircraft in the electronics test laboratory and in the sales and service departments.

Mr. Hackett, who is 28, is married and has two children.

Heating Controls and Devices Ltd. is a subsidiary of Clyde Fuel Systems, Ltd., Queen Elizabeth Avenue, Hillington, Glasgow, S.W.2. As well as their Dublin office the firm intends to establish branches in several centres in England and Scotland.

They are stockists and suppliers of many types of controls by Satchwell, Danfoss, Maclaren, Proscion and Kingston; time switches by Venner, Sangamo, Horstman; pumps by Ryaland, BSA Harford, Tropic, Rotherham and other leading makes; tank gauges by K.D.G., Normond, Funder, Bayham, Seetru and Midbrass; filters by Airpel, Cooper and Wix; boilers by Wilson, Graham Stewart, Crane, Ideal and Trianco, etc., and are the sole distributors in Ireland for Hotspur, Duncan low oil heaters and Anglo-Nordic Burner Products.

They intend building up very large stocks of all items of controls and heating equipment in all their branches, and give an immediate service to customers. The company also has a factory making control panels, instrument panels, contractor panels and switchboards, and hope to be able to send these to Eire.



**ANTRIM FIRM TAKE TO THE AIR**

Sitting behind the controls of the Musketeer aircraft, recently acquired by Everton Engineering Ltd., is Mr. George Leckie, director and general manager of the firm. The plane will be used by this go-ahead concern to cut travelling time and improve business communications both in Britain and Ireland. Everton Engineering Ltd. are a Newtownabbey, Co. Antrim firm.

**VALOR TURN  
LOSS TO PROFIT**

A £64,000 loss turned into a £97,000 profit last year and "some further improvement in our results for 1963." This was part of the statement issued recently by Sir Leonard Sinclair, chairman of the Valor Company.

Due partly to the unprecedented demand for paraffin heaters and cookers during the "big freeze," Sir Leonard also attributed the boom to the company's diversification move into domestic appliances.

It's an ill wind that blows nobody good.

**Fenton Byrn  
Appoint Agents**

FENTON BYRN and Company Ltd., fan manufacturers and heating engineers of West Molesey, Surrey, have officially appointed McGregor and Manning of Belfast to handle their business in Northern Ireland.

Founded five years ago by Mr. D. A. McGregor and H. W. Manning, the partners have gone from strength to strength over the period specialising in equipment peculiar to the plumbing and heating trade. As well as the

Northern firm, W. Finucane & Co. of Dublin are to be the agents for the 26 Counties.

Both agents will handle the complete range of fans, heaters and motorised roof cowls manufactured by Fenton Byrn, one of the leading producers of heating and ventilating equipment in Britain.

Recently, the company has added to their range of convector heaters to give heat outputs from 8,000-110,000 B.T.U.s per hour, suitable for installations ranging from domestic to large industrial. In the middle ranges, the heaters can be fitted with attractive wood surrounds. Another Fenton Byrn modification recently introduced is their "low-line" glass fibre motorised cowls for flat or pitched roofs.

The company also produces a wide range of wall fans and axial flow fans for ventilation. One model is "daught-proof"—a grille automatically closes when the fan is switched off to prevent back draught and the ingress of dust.

**MARRIED:** Dugald Macfarlane (25), director of Messrs. Peter Macfarlane & Son Ltd., Engineering Agents, of Cupar Street, Belfast, to Miss Anne Erskine, Ballyhackamore, Belfast, on April 26, at Helen's Bay, Co. Down. The honeymoon was spent in Spain.

When a plumber is looking for a



pump...

...for **CENTRAL HEATING**

he cannot buy better  
than the

# **SIGMUND THERMOPAK or SILENTFLO**

and the prices are very competitive. Why not buy the best at practically  
no extra cost ?

### **SPECIAL FEATURES:**

- Super Silent and self-lubricating.
- Being glandless, is free from leaks and needs absolutely no attention whilst operating.
- Special silicon-impregnated winding—no starter protection needed.
- Precision-ground sleeve bearings—for long life.

PRICES AND ILLUSTRATED LITERATURE SENT ON APPLICATION.

**ONLY AVAILABLE FROM THE SOLE AGENTS FOR REPUBLIC  
OF IRELAND:**

## **MONSELL, MITCHELL & CO. LTD.**

67-73 TOWNSEND STREET, DUBLIN 2.

Phone 76282

**FULLY GUARANTEED  
AND COMPLETE AFTER  
SALES SERVICE AVAIL-  
ABLE.**

# **M. A. B. INSULATIONS**

*Specialists  
In Sound  
Attenuation  
and Thermal  
Insulation  
of Ducting*

**SOLE CONTRACTORS IN IRISH  
REPUBLIC FOR—  
THE FAMCLAD SYSTEM**

Estimates and Specifications Free on request.  
**45, WATERLOO ROAD, BALLSBRIDGE,  
DUBLIN. Telephone: 684017.**

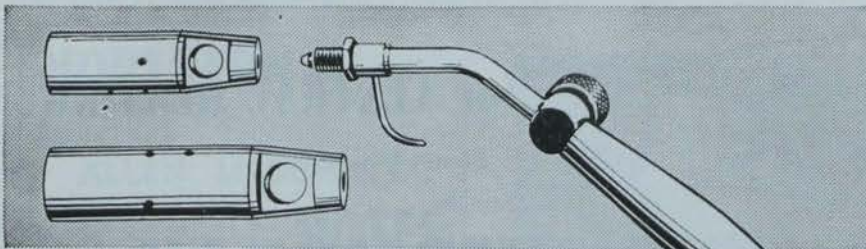

(TH3) (TH4) Kosangas High Pressure Blow Torch. Wooden handle. Needle control valve, for gas adjustment. Supplied with large or medium burner heads.

# Kosangas Blow Torches

*for every plumbing job!*

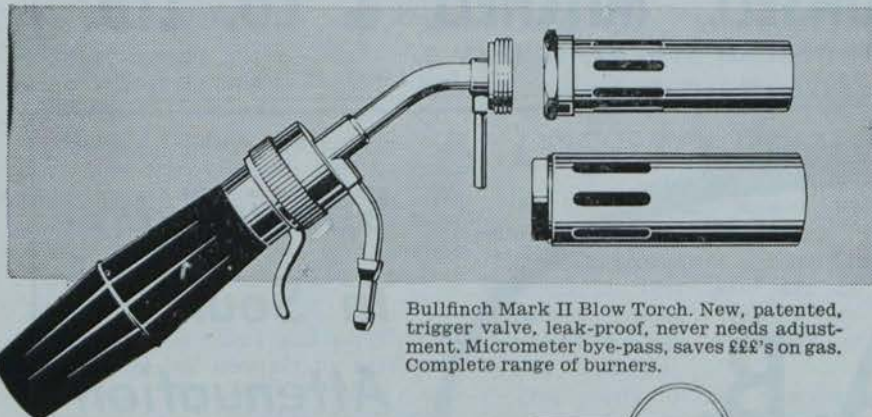

Bullfinch Mark II Blow Torch. New, patented, trigger valve, leak-proof, never needs adjustment. Micrometer bye-pass, saves £££'s on gas. Complete range of burners.

Make full use of the wide range of Kosangas blow torches, available for plumbing work. They're much more efficient than the conventional type.

The Kosangas TH3 and TH4 are designed for paint burning, pre-heating and soldering. The Bullfinch Mark 2 has a wide variety of heads, including soldering attachment. In conjunction with the small portable Kosangas cylinder, use Kosangas blow-torches for:

- PAINT BURNING · PRE-HEATING
- SOLDERING · ROOF FELTING
- JOINTING OF PLASTIC PIPES
- ANY OTHER HEATING NEEDS

The Kosangas plumber's portable furnace, with wind protected burner, is excellent for outdoor plumbing and cable work, requiring liquid asphalt, pitch, zinc, lead, tin and other fusible materials.

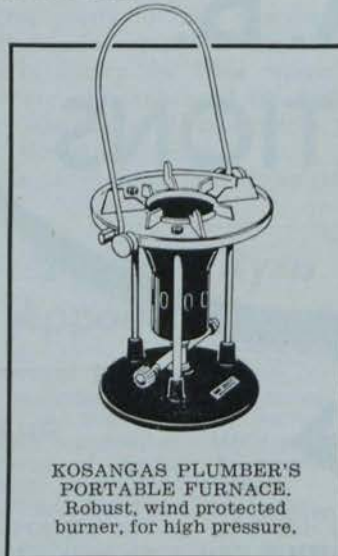

KOSANGAS PLUMBER'S PORTABLE FURNACE. Robust, wind protected burner, for high pressure.

Send for fully descriptive lists and leaflets to:

McMullans Kosangas Ltd., 1, Upper O'Connell St., Dublin. Tel. Dublin 40761-4.

<https://arrow.tudublin.ie/bsn/vol3/iss2/1>

DOI: 10.21427/D7GH7C

Thirty-two

## TRADE

## TOPICS



### IMPROVED REDFYRE INTRODUCED

AN IMPROVED model of their popular Redfyre Magazine Boiler has just been introduced by Newton Chambers & Co. Ltd., of Thorncliffe, Sheffield. Known as the Redfyre Series 2, Magazine Boiler, this incorporates a draught stabiliser in the flue offtake.

With a continuous rating of 20,000 B.t.u.'s/hr., the model includes thermostatic control, magazine feed, easy re-fueling, dust-free shaking and a wide ashpan. The casing of vitreous enamel is in white or cream with black top plate and lid and there is a choice of red, green, blue or black for the handle and thermostat knob. A stainless steel strip set below the hopper lid gives a neat finish to the front.

Irish agents: Baxendale & Co. Ltd., 7 Capel St., Dublin; W. P. F. Hume, Ltd., 6-12 Hyndford St., Belfast, 5.

★ ★ ★

● MR. ALAN LINDSAY CRAMB, M.I.E.E., M.I.Mar.E., D.F.H., has been appointed Sales Director of Sigmund Pulsometer Pumps Ltd., Gateshead. He was previously Sales Director with the Brush Electrical Engineering Co. in Britain.

fully dealt with later on, but in the meantime our illustration shows one type of polythene joint where a copper tube compression fitting is adapted for the purpose. Notice the copper internal liner which supports the plastic tube against the compressive forces of the joint. Notice also that because of the greater wall thickness of polythene tube the copper fittings have to be one size larger than the nominal bore of the polythene tube. For example,  $\frac{1}{2}$ " polythene needs  $\frac{3}{4}$ " copper fittings, and  $\frac{3}{4}$ " polythene needs 1" copper fittings.

Specially developed joints for polythene tube include the type illustrated here. This is a union form of joint which introduces no metal into the inside of the pipeline. It also has

from page twenty-eight

## DOMESTIC WATER SUPPLY

the advantage of being a "positive" joint which cannot pull off the tube, and as such it is the best for underground pipelines. Its making involves a special set of tools and a blow-

lamp. The tools can be borrowed quite cheaply from the firm which designed the joint; they advertise regularly in the trade journals.

### Special joint

**A**NOTHER specially developed form of joint is illustrated here. Here the inside wall of the fitting socket is made to fuse and weld itself to the wall of the tube. In this case the fusion is obtained by heating a special tool, again supplied on loan by the manufacturers of the joint, and putting the tube end inside the tool, and the socket of the fitting to the outside of the tool, for a few seconds. The polythene surfaces melt or fuse, and when the tube end is introduced into the socket and held in place for a few seconds the fused surfaces unite, or weld together.

Other fusion fittings have an electrical resistance wire embedded in the socket of the fittings. The joints are assembled by "push fit", and the ends of the wires connected to an electric battery. The electric current flows through and heats the wires, producing the heat necessary to fuse the pipe wall and socket surfaces together.

### Disconnecting joints

**T**HE illustration shows the arrangement and effect of parallel to taper threads and taper to taper threads. It will be noted that the continuous contact of the latter makes it a better joint from the strength point of view, and it needs only a lick of compound.

**Unions** or other forms of disconnecting joints are very necessary in all pipework. If they are properly placed and used they are economical since sections of pipework can be pre-fabricated on the bench and easily coupled up to other sections in the building. They also made it easier and quicker to disconnect the pipework when it is repaired.

**Disconnecting joints** may simply be brass or copper "cap and linings," such as are used for ballvalves, stop taps, bath and basin taps, etc.

For copper tube work they may be dismountable compression fittings which permit breaking down and re-assembly of the pipe without requiring new fittings.

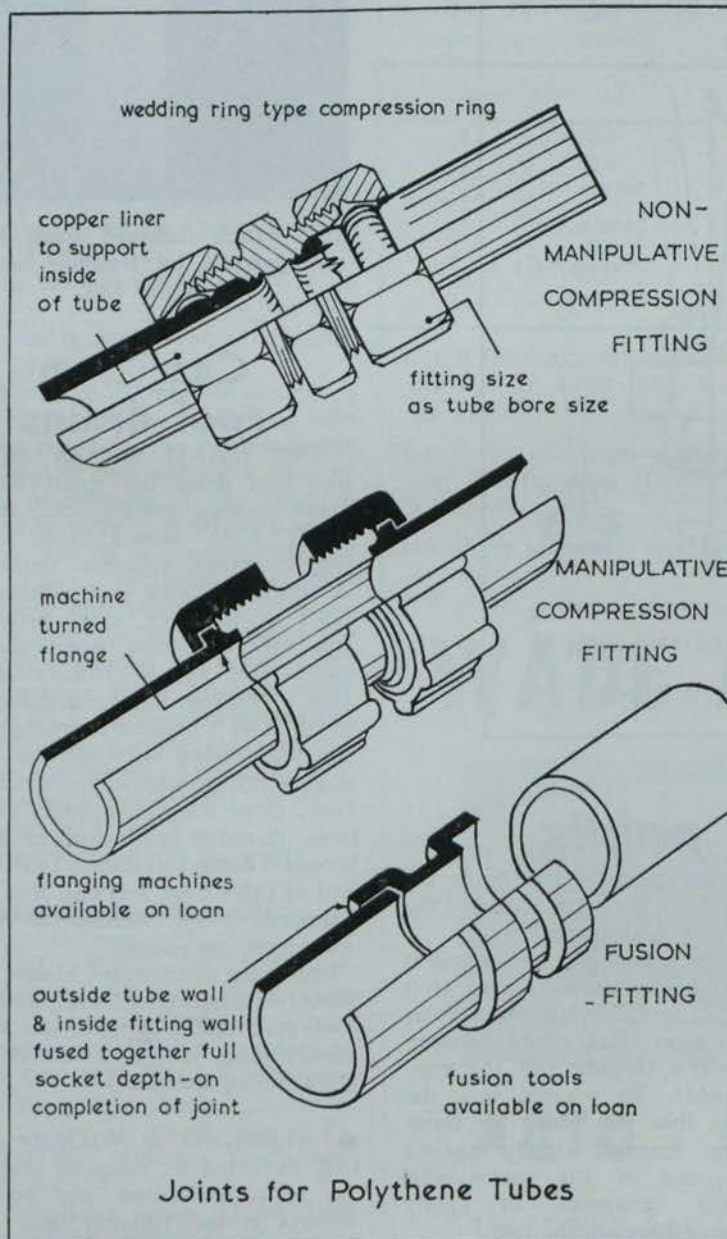

Continued overleaf

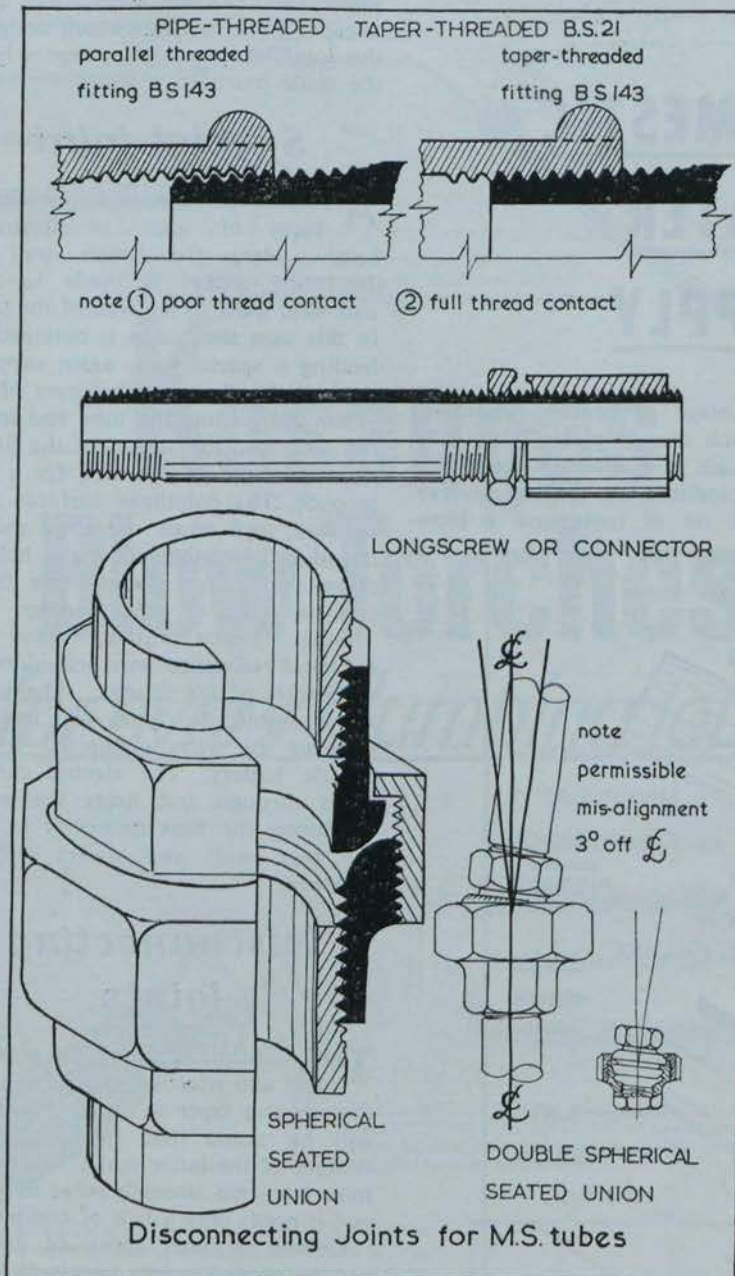

from previous page

## Well selected points

**WHEN** solder capillary fittings are used it is desirable to introduce unions at carefully selected points.

Mild steel tubes should be provided with unions which are to be preferred, or, in many cases the "longscrew" or connector is used (illustration). The "longscrew" consists of a long parallel thread along a short piece of pipe which has an ordinary taper thread at its other end. A parallel threaded back nut and socket is run on to the longscrew, and the socket is run off the longscrew on to the taper thread if the

pipe is being connected; or on to the longscrew from the taper thread if the pipe is being disconnected.

No hemp or jointing compound is applied to the connector thread as it is with taper screwed pipe ends. Water could, therefore, leak along between the longscrew threads and the connector socket. To prevent this, the backnut is then run along the longscrew and screwed tightly against the back end of the socket with a prepared "grommet" of tightly twisted hemp between the two.

## TRADE

## TOPICS



The stylish Ashford wash basin and pedestal by Doulton Sanitary Potteries Ltd.

## Cast iron roof drains

THE JOSAM SERIES 440 cast iron roof drain for small flat roof areas, valleys, gutters, etc., features an 8½" x 8½" square flange for setting in screed, concrete, timber, etc. A combined dome and sediment cup (29.2 sq. ins. free area) provides a free waterway even when sediment cup is full, and is virtually unchokable. Medium size sump dimensions of 6½" x 4½"; positive clamping device for felt roofing with integral gravel stop, which is essential for mineralized felts; three alternative outlet connections (threaded, inside caulk or spigot); bronze dome available as standard at extra cost; and cast iron dome supplied Vinyl weatherized at no extra cost, on request.

Irish main distributors, Messrs. Thos. Dockrell, Sons & Co., Ltd., South Gt. Georges Street, Dublin, 2; and Messrs. Joseph Blair, Ltd., 5-19 Church Lane, High Street, Belfast, 1.

● ALBRIGHT & WILSON (Mfg.) Ltd. exhibited its range of chemicals for scale prevention and corrosion control at the Effluent and Water Treatment Exhibition at the Seymour Hall, London, W.1.

specific gravity it is not heavy, and this, together with the fact that it is flexible, means that even a 500-ft. length can still be handled reasonably easily. Other lengths may be supplied to order. If the tube is coiled it must be done at a temperature of less than 30°C., and the minimum internal diameter of the coil should be as follows:—

**TABLE 4**

Nominal bore (in)	Recommended minimum internal diameter of coil (ft in)	
	ft	in
½ and less	3	6
¾	3	6
1	4	0
1¼	5	0
1½	6	0
2	7	0

The purpose of these specifications for the minimum internal diameter of coils is to obviate the stress that would probably occur in the material if the tubes were coiled at a smaller diameter. When it leaves the manufacturer the ends of the tube have to be plugged or covered. Tubes can also be supplied in straight random lengths, up to 20 ft. long.

Polythene tube must withstand a test pressure, and each batch of tube must be tested by the manufacturers to see that it does not show signs of leakage or weeping at the required standard pressure. A tensile strength test has also to be applied, and the tensile strength of the material must be not less than 1400 lb./sq. in.

When used for water services the tube will normally be continuously under pressure, either from the water main or from the head of water from a cistern. The working pressures that may be continuously applied at temperatures not exceeding 20°C. or 70°C. are shown in Table 3.

**POLYTHENE TO BRITISH STANDARD 3284: 1961.**

**BRITISH** Standard Specification 3284:1961, **Polythene Pipe (Type 710) for Cold Water Services**, has been published as a Standard complementary to B.S. 1972: 1961, cover polythene tube which, although basically similar to the polythene covered by B.S. 1972, has different mechanical characteristics.

The polythene pipes (Type 710) covered by this British Standard are classified as follows:—

# PLASTICS IN PLUMBING

*from page eleven*

**TABLE 3—British Standards 1972: 1961 Recommendations for Polythene. Normal gauge tube**

Nominal bore (in)	Approximate weight (lb/100 ft)	Working pressure (lb/sq. in.)	pressure (ft head)	Nominal outside diameter (in)	Wall thickness (in)
½	7.0	130	300	0.686	0.093
¾	14.0	115	115	1.000	0.125
1	18.0	90	90	1.250	0.125
1¼	22.0	75	75	1.500	0.125
1½	29.0	75	70	1.750	0.140
2	53.0	75	70	2.375	0.187

**Heavy gauge tube**

½	7.0	285	660	0.531	0.141
¾	11.0	230	525	0.677	0.151
1	15.0	210	480	0.840	0.173
1¼	21.0	150	350	0.096	0.173
1½	27.0	115	255	1.346	0.173
2	38.0	120	245	1.661	0.203
2½	46.5	105	235	1.891	0.215

Class B for maximum working pressure 200 ft. head (86.7 lb./sq. in., 6.1 kg/cm<sup>2</sup>).

Class C. for maximum working pressure 300 ft. head (130 lb./sq. in., 9.1 kg/cm<sup>2</sup>).

Class D for maximum working pressure

400 ft. head (173.4 lb./sq. in., 12.2 kg/cm<sup>2</sup>).

The pipes have to be marked indelibly at intervals of not more than 10 ft. (3 m). The marking must show the manufacturer's identity, the class, size, table number, and the number of the B.S. 3284. The marking must

*Continued overleaf*

## WADE MINI - PUMP

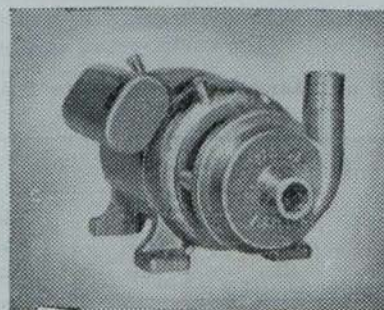

**SMALLEST IN OUR RANGE OF CENTRIFUGAL PUMPS**

250/600 G.P.H.  
LOW PRICE  
£12 15 0 LIST  
GENEROUS TRADE DISCOUNTS.  
INDUCTIONS MOTORS  
NO BRUSHES.

**AUTO - COMBUSTIONS (IRELAND) LTD.**

144 LOWER BAGGOT ST., DUBLIN, 4. Phone 66338.

**TABLE 5—Dimensions of Pipes to B.S. 3284 : 1961**  
(General Plastics Pipe Series).

Nom. bore (in)	Min. o.d. (in)	Max. o.d. (in)	Class B		Class C		Class D	
			Min. wall (in)	Max. wall (in)	Min. wall (in)	Max. wall (in)	Min. wall (in)	Max. wall (in)
3/8	0.667	0.682	—	—	0.060	0.068	0.074	0.082
1/2	0.832	0.848	0.060	0.068	0.071	0.079	0.092	0.101
3/4	1.043	1.061	0.070	0.078	0.089	0.098	0.115	0.127
1	1.311	1.332	0.085	0.094	0.112	0.123	0.145	0.160
1 1/4	1.654	1.679	0.096	0.106	0.141	0.155	0.182	0.200
1 1/2	1.888	1.915	0.110	0.121	0.160	0.176	0.208	0.229
2	2.363	2.395	0.138	0.152	0.201	0.221	0.260	0.286

1 in. = 25.4 mm. exactly.

from previous page

also be in the following colours: Class B red, Class C blue, Class D green.

For the outside diameters and wall thicknesses the pipes must conform to Tables 5 and 6.

**Smooth, clean**

AS with other plastics pipes, the internal and external surfaces of the pipe have to be smooth, clean, and reasonably free from grooves and other defects. The pipes must also be capable of withstanding appropriate hydraulic test pressures without showing signs of leakage or weeping:

- Class B 173 lb./sq. in. (12.2 kg/cm<sup>2</sup>).
- Class C 260 lb./sq. in. (18.3 kg/cm<sup>2</sup>).
- Class D 346 lb./sq. in. (24.3 kg/cm<sup>2</sup>).

The pressure has to be applied when the pipe is at room temperature, and must be maintained for a period of not less than two minutes.

A tensile strength of not less than 2700 lb./sq. in. (190 kg/cm<sup>2</sup>) is required and an elongation break of not less than 150%. As previously stated, the mechanical properties of polythene are adversely affected by a rise

in temperature, and it should not be used for hot water services or fixed in contact with hot surfaces.

The pipe is supplied in random lengths or in coils of 50 ft., 200 ft., 500 ft., or greater as required.

As far as jointing is concerned, the specification states that manufacturers should be consulted with regard to suitable fittings, but that compression fittings to B.S. 864 will suit the sizes of pipe listed in Table 5.

Bends can be made when the radius is greater than 12 times the outside diameter of the pipe. For tighter radius bends the bends should be made as described earlier. The heat may be applied by means of a saturated salt solution, or glycerine, at a temperature of 120°C.

**Straight Lengths**

IN fixing, straight lengths are preferred for surface installations. Where coiled pipe is used for this purpose it is wise to arrange the pipe so that curvature is corrected by contact with the surface to which it is fixed. The coefficient of expansion is

such that an increase in length of 1/10th in. per 10 ft. per 10 Fahrenheit degrees (1.5 mm/m/1°C.) rise in temperature is likely to occur, and a corresponding decrease when the temperature is reduced. The pipes should therefore be fixed firmly but not tightly, and provision for expansion and contraction may be necessary in long runs. It is best for the pipe to have continuous support, but when pipe clips are used for horizontal runs the spacing of these should be as follows:—

**TABLE 7**

Nominal bore (in)	All classes (ft)
3/8	2
1/2	2 1/2
3/4	2 1/2
1	2 1/2
1 1/4	3
1 1/2	3
2	4

For vertical runs the supports should be fixed at not more than twice the distances for horizontal runs.

(TO BE CONTINUED)

**TABLE 6—Dimensions of Pipes to B.S. 3284 : 1961**  
(B.S. 1972 Series).

Nom. bore (in)	Min. o.d. (in)	Max. o.d. (in)	Class B		Class C		Class D	
			Min. wall (in)	Max. wall (in)	Min. wall (in)	Max. wall (in)	Min. wall (in)	Max. wall (in)
1/2	0.671	0.686	—	—	0.060	0.068	0.075	0.083
3/4	0.982	1.000	0.070	0.078	0.084	0.092	0.109	0.120
1	1.230	1.250	0.085	0.094	0.105	0.116	0.136	0.150
1 1/4	1.477	1.500	0.095	0.105	0.126	0.139	0.163	0.179
1 1/2	1.725	1.750	0.110	0.121	0.147	0.162	0.190	0.209
2	2.344	2.375	0.136	0.150	0.199	0.219	0.258	0.284

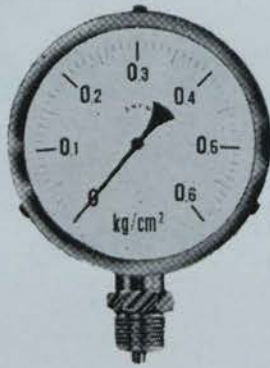

● A complete line of Gauges always in stock.

# Investigate the Manotherm Range of Gauges and Corrosion Resistant Thermometers –

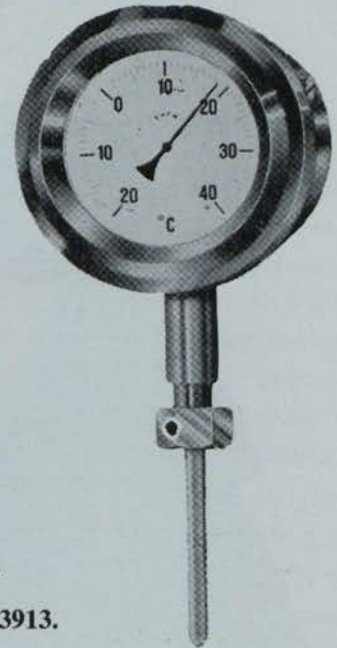

## MANOTHERM LTD.,

14 CORN EXCHANGE BUILDINGS, BURGH QUAY, DUBLIN. Tel. 73913.

# READERS ENQUIRY SERVICE AND SUBSCRIPTION FORM

POST TO: IRISH TRADE AND TECHNICAL PUBLICATIONS LTD., CALLAGHAN CHAMBERS, 13/15 DAME STREET, DUBLIN, 2. TELEPHONE 56465/6.

Please send me particulars of the following, as seen on page.....of the.....issue

Name and Address.....  
.....

### SUBSCRIPTION FORM

Please send me "The Irish Plumber and Heating Contractor" every month until further notice.  
I enclose subscription of One Guinea.

Signed .....

Name of Firm .....

Address .....

.....

.....

.....

Date.....



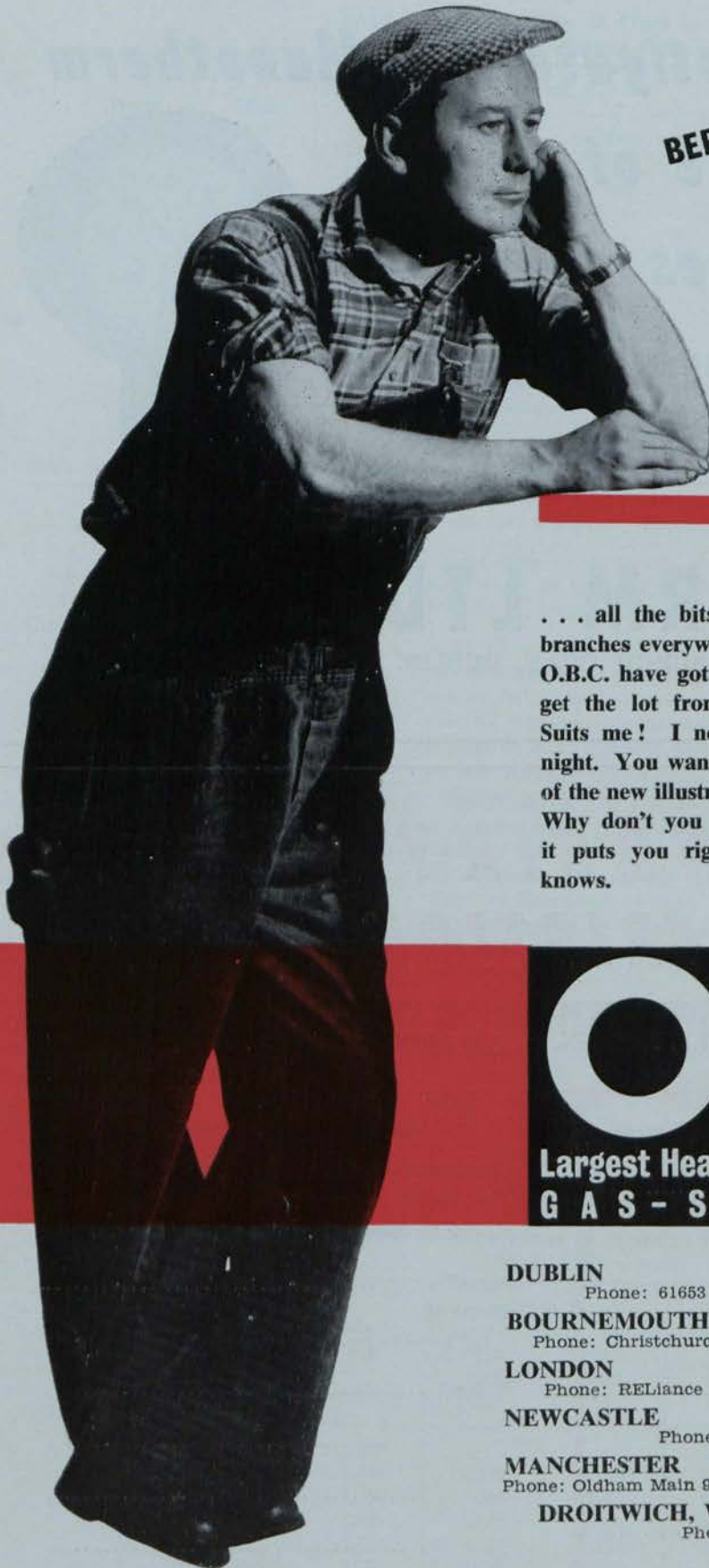

**BERT SAYS  
OBC HAVE GOT EVERYTHING  
BERT KNOWS!**

... all the bits and pieces for any heating job ... branches everywhere ... smashing service. Bert's right, O.B.C. have got everything. And, of course, when you get the lot from O.B.C. it means only one invoice. Suits me! I never was one for sitting at a desk all night. You want to get hold of a copy of the new illustrated O.B.C. Catalogue. Why don't you send now? Bert says it puts you right on any job. Bert knows.



**OBC**   
LTD.  
**Largest Heating Equipment Merchants**  
**GAS - SOLID FUEL - OIL**

**DUBLIN**

Phone: 61653 & 63061.

**BOURNEMOUTH**

Phone: Christchurch 1522/3

**LONDON**

Phone: RELiance 7971/2/3.

**NEWCASTLE**

Phone: 810857.

**MANCHESTER**

Phone: Oldham Main 9488/9/90.

**BELFAST**

Phone: 31576.

**BRISTOL**

Phone: 293774/5/6

**LEICESTER**

Phone: 74908.

**GLASGOW**

Phone: DOUGlas 5115.

**CARDIFF**

Phone: 28613/4/5.

**DROITWICH, Worcs. (Head Office and Works)**

Phone: 2551 (10 lines).