

4-1-1963

The Irish Plumber and Heating Contractor, April 1963 (complete issue)

Follow this and additional works at: <https://arrow.tudublin.ie/bsn>



Part of the [Civil Engineering Commons](#), [Construction Engineering Commons](#), and the [Construction Engineering and Management Commons](#)

Recommended Citation

(1963) "The Irish Plumber and Heating Contractor, April 1963 (complete issue)," *Building Services Engineering*: Vol. 3: Iss. 1, Article 1.

doi:10.21427/D7BQ42

Available at: <https://arrow.tudublin.ie/bsn/vol3/iss1/1>

This Article is brought to you for free and open access by the Journals at ARROW@TU Dublin. It has been accepted for inclusion in Building Services Engineering by an authorized editor of ARROW@TU Dublin. For more information, please contact arrow.admin@tudublin.ie, aisling.coyne@tudublin.ie, vera.kilshaw@tudublin.ie.

THE IRISH PLUMBER & HEATING CONTRACTOR



VOL. 3. No. 1.

APRIL, 1963

The way we make heating and cooling coils is unconventional. The tubes pass through a series of perforated plates mechanically bonded by a special tube expansion process. Result—a perfect metal to metal contact that no amount of expansion or contraction can affect. Also, a more than usually efficient and uniform distribution of heat from a more durable unit.

The choice of tube metal, of size and capacity, is up to you. There is, of course, a standard range and it is a very extensive one. For details please write or 'phone any of the addresses below, Dept. I.P.1,

COIL FINNS THAT DON'T SPIRAL & ARE ALL THE BETTER FOR IT!..

BIDDLE COILS

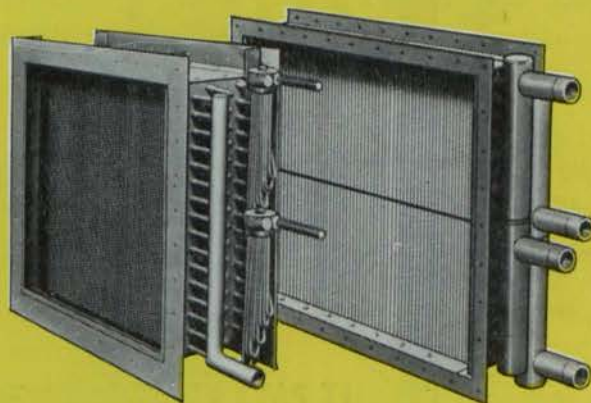

BIDDLE Quality controlled products



F H BIDDLE LIMITED (British Trane Co Ltd—Manufacturing Division)
16 Upper Grosvenor Street, London W1 Hyde Park 0532

TECHNICAL REPRESENTATIVES
D. H. BUTLER, 7 Blackwood Crescent, Helen's Bay, Belfast
Telephone: Helen's Bay 2119
QUADRANT ENGINEERS, 167 Strand Road, Sandymount,
Dublin 4. Telephone: Dublin 693940

BIG 4 FOR ALL PLUMBING & HEATING CHOSEN BY CRAFTSMEN

1 INSTANTOR the most efficient joints in the world
for copper tubing. Equally reliable
for use with plastic pipes.

2 ENDEX capillary fittings for small-bore central
heating—efficient, unobtrusive and cheaper
to install.

3 CONEOR go underground with safety. Coneor couplings
are zinc-free gunmetal castings specifically
chosen for use with soft copper tubing.

4 FYFFE'S up-to-date range of *PLUMBERS' BRASS
WARE* is at your stockist's now. All patterns
can be supplied—polished or chromium-plated.

ADD THEM UP TO A FIRST CLASS JOB

IT PAYS TO KEEP TO THE FYFFE LINES

Sanbra Fyffe Limited.

Instantor Works, James's Street, Dublin, 8.

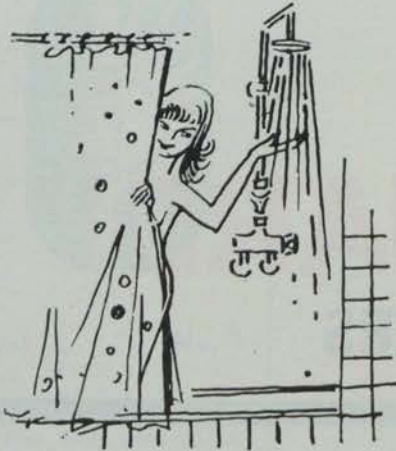

GROHE *Thermostat* with Temperature Gauge

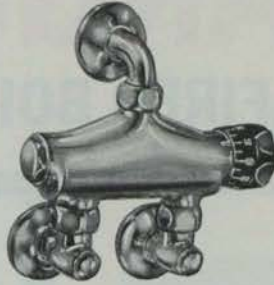

Automatically Controlled Thermostatic Mixing Valves

Turn the gauge to the temperature required. Mixed Hot and Cold water of any temperature between 50° F. and 160° F. will be delivered automatically. The chosen temperature remains constant and no further adjustment is required. Detailed information is available from our Irish representatives.

Friedrich Grohe. Hemer.
Grohe Thermostat. Lahr.
Hans Grohe. Schiltach.

Agents
in
Ireland: **Norman Stewart Ltd.,
Central Hotel Chambers,
Dame Court, Dublin.**
Telephone: Dublin 73086.



SANITARY WARE IN WHITE AND COLOUR

(Colours to match Irish Foundries Ltd.)

Agent:
C. B. SHERIDAN
10 HERBERT PLACE
DUBLIN.
Phone 66283.

Illustrating
"THE WALDORF SUITE"

JOHNSON AND SLATER (VITREOUS CHINA)

ALFRED JOHNSON & SON LTD.,
QUEENBOROUGH, KENT.

JOHN SLATER (STOKE) LTD., (SANITARY FIRECLAY)

BERRY HILL, STOKE-ON-TRENT.

**EASIER
TO
INSTALL**

NEW "IDEAL VANGUARD" OIL-FIRED BOILERS

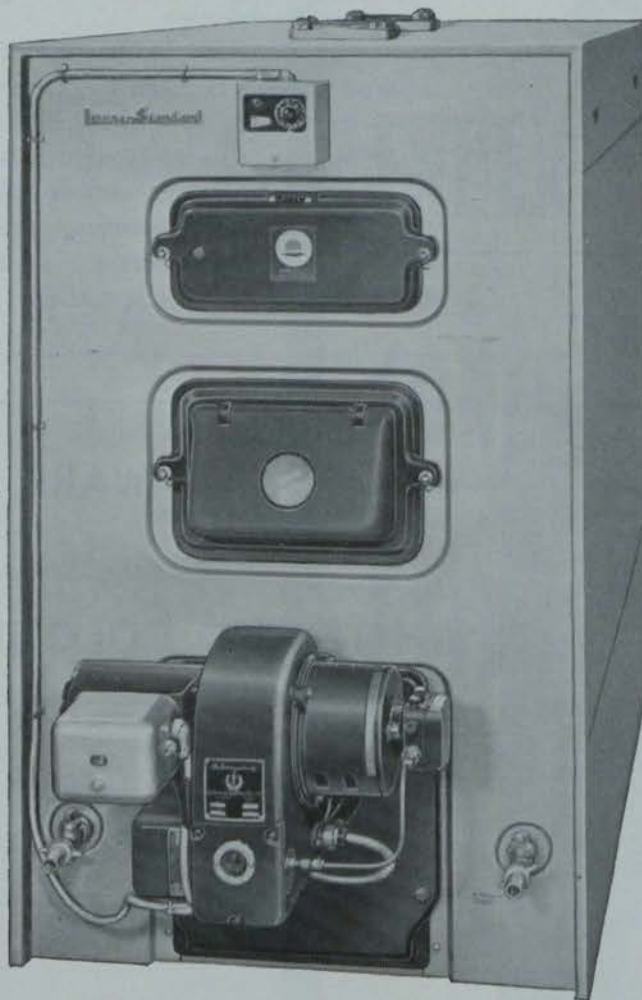

- * Matched boiler/burner unit
- * Pre-set air/fuel ratio
- * Integral draught stabiliser
- * New high efficiency cast-iron sections*
- * Easy servicing and maintenance

The "Vanguard" is supplied as a matched boiler/burner unit, in a range of seven sizes, giving outputs from 175,000 to 385,000 BTU's per hour, and is available with a choice of either "Camron" or "Selectos" oil burners, which have been specially developed for use with this boiler.

The "Vanguard" is designed for speedy installation, easy servicing and maintenance. These features, combined with the pre-set air and fuel control, smart appearance, and many other advantages, make the "Vanguard" an important addition to the "Ideal" range of boilers.

* Patent applied for No. 27603

THE "IDEAL VANGUARD" is available now

Contact your "Ideal" representative for full details or write to:

IDEAL - Standard LIMITED IDEAL HOUSE · GREAT MARLBOROUGH STREET · LONDON W1



THE IRISH PLUMBER & HEATING CONTRACTOR



Vol. 3. No. 1

The only publication in Ireland for the craftsman plumber and contractor, the heating, ventilation, insulation, air conditioning and refrigeration engineer and contractor, the electrical contractor, supplier, manufacturer and wholesaler of fittings and equipment for the trades.

Published monthly by Irish Trade & Technical Publications Ltd. Annual subscription, 21/-, post free. Single copies, 1/9, post free.

Editorial and advertising offices:

Callaghan Chambers,
13/15 Dame Street,
Dublin, 2. Tel. 56465-6,
London: J. T. Robson
& Son Ltd., 30 Fleet
Street, London, E.C.4.
Tel.: Fleet Street 4438.

APRIL, 1963.

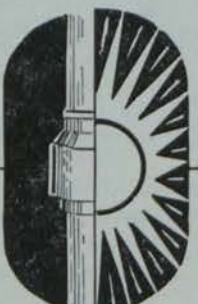

IN THIS ISSUE

A Contractor reporter gauges trade reaction to the recent Dail statement that central heating installation will increase rateable valuations	4
A. L. Townsend, M.R.S.H., M.I.P., this month deals with joints for pipework ...	7
A new contributor joins the Contractor panel—W. J. Woolgar, F.R.S.H., A.M.I.P.H.E., F.I.O.P. This month we begin the serialisation of his important, just published work, <i>Plastics In Plumbing</i>	16
Northern Notes, on clean air control, are on page.. .. .	24
Corrosion in metal tubes and fittings is John G. Bolton's topic	27
Continuing last month's Special Survey article on industrial, commercial and hospital sanitary ware	31
Mr. Derry McCaffrey, M.A., A.M.I.C.E., A.M.I.C.E.I., suggests special legislation to beat heat losses	34
Trade Topics begin on page six.	
SPECIAL SURVEY: Review of water circulators and pumps, water pumping and storage equipment beginning page eleven.	
SPECIAL SURVEY: Review of water treatment chemicals and softening plants beginning page twenty.	

INDEX TO ADVERTISERS

Biddle, F. H., Ltd.	Cover i	Johnson & Slater Ltd.	1
Boylan, M. A., Ltd.	23	John Thompson Group	18
Carthorn (1949) Ltd.	15	Leinster Engineering Co. Ltd. ..	5
Clyde Fuel Systems Ltd.	19	M.A.B. Insulations Ltd.	33
Dockrell, Thos., Sons & Co., Ltd. ..	19	Manotherm Ltd.	13
Du Bois Co. Ltd., The	30	McMullans Kosangas Ltd.	30
Grohe, Friedrich	1	Monsell, Mitchell & Co. Ltd. ..	15
Halpin & Hayward Ltd.	22	O.B.C. Ltd.	10
Hendren Bros. (Dublin) Ltd.	14	Pickup, H. (Scarborough), Ltd. ..	26
Holden & Brooke Ltd.	12	Proops Bros., Ltd.	6
Holfeld, H. R., Ltd.	25	Sanbra-Fyffe Ltd.	Cover ii
Ideal-Standard Ltd.	2	Unidare Ltd.	Cover iv
Industrial Gases (I.F.S.) Ltd.	36	Wavin Pipes Ltd.	33
Irish Feedwater Specialists Co. Ltd. ..	22	Welding Services Ltd.	35
		Willis, Wm. & Co., Ltd.	24

The Irish Plumber and Heating Contractor.

Reporting

The background and trade reaction to the recent Dail statement that central heating installation would result in rateable valuation increases

DISMAY AND INDIGNATION FOLLOW DAIL STATEMENT

WHAT a wave of incredulous dismay and indignation followed the statement of Mr. Donough O'Malley, Parliamentary Secretary to the Minister for Finance in the Dail on March 20, that the Commissioner of Valuations regards central heating as a cause for higher valuations on houses in which it is installed! Of the 170 odd pages of closely packed script which go to make up the catalogue of the Dail debates for that one day probably no single item has created more discussion than the two brief paragraphs in which the whole subject was dismissed.

For thousands of householders throughout the country—those already in centrally heated new houses and those about to purchase—Mr. O'Malley's statement has turned the clock back many years. People who thought of rack rents and the penal laws only as words in the history books have been rudely awakened to the fact that there are some aspects of property ownership which have not changed a bit since the "bad old days." The one basic fact is that if you carry out improvements to your property, be it land or buildings, your valuation will, sooner or later, be increased.

Have suffered

Down the years farmers, shopkeepers and plain ordinary householders have suffered, sometimes silently, sometimes volubly but almost always ineffectively as their valuations soared following some improvement to their properties and because they were individuals and their cause none but their own, their protests died quietly in the inexorable march of officialdom and red tape.

by _____
A Contractor
Reporter

bleats drowned in the roar of legislative machinery.

Central heating is but one form of improvement which can lead to higher valuation but because it is the form which has affected the community collectively it is the issue on which the whole injustice of the valuation laws is now being brought home to the houseowner.

To put the whole subject in its original perspective we must go back to March 20 in the Dail, when Mr. R. Ryan, T.D., asked the Minister for Finance whether it was the practice of the Valuation Commissioners to increase the valuation of a house which has central heating installed; if so, if he would indicate why, and under what authority; and whether he would introduce legislation to prevent such increases being made, having regard to the fact that they discourage modernisation.

Parliamentary Secretary Mr. O'Malley replied that it was the duty of the Commissioner of Valuation to ensure that the valuation in regard to buildings was made on an estimate of their net annual value, as stipulated in Section II., Valuation (Ireland) Act, 1852.

He added: "I am informed by the Commissioner that he would regard the installation of central heating as a factor enhancing the value of a building, so that the valuation made

would normally be higher by reason of the central heating.

"I do not propose to introduce legislation as suggested by the Deputy, nor do I accept that such valuation increases discourage modernisation any more than increases arising from other improvements which must be taken account of in a system of taxation on property values."

Another airing

In the first week of April the matter got another airing and this time no less a person than the Minister for Local Government, Mr. Neil Blaney, gave his views. The discussion arose out of the debate on the Local Government (Temporary Reduction of Valuation) Bill, 1963, in the Senate. The Bill incidentally proposes to continue for three further years, from last April 1, the period in which buildings may be erected, enlarged or reconstructed in order to qualify for the rates of remission under the Local Government (Temporary Reduction of Valuation) Act, 1954.

Mr. Blaney, referring to the central heating announcement by Mr. O'Malley in the Dail, said that central heating increased the valuation of a house. He added that people who could afford central heating were, perhaps, better able to bear the burden of the additional rates than the general ratepayer or taxpayer. The Commissioner of Valuations was quite entitled to take it into account in determining the valuation of the houses.

"But," added the Minister, "I am not saying that I agree with that, but it is not really within my authority." Never before has there been such a

from previous page

"A change in legislation is the only solution"

—Heating Manager

demand for central heating. Hand in hand with the building boom, the central heating trade is making phenomenal progress and what was generally regarded as a luxury has in a very short time come to be regarded as a necessity by more and more people.

What views?

With a view to finding just what the thinking on the subject is among the people most vitally concerned, along with the general public, we interviewed the Managers of home heating departments of a number of firms whose business is the installation of central heating, either by oil, solid fuel, gas or electricity.

Mr. T. P. Hayes, B.E., of the Esso Home Heating department, said: "When we first read Mr. O'Malley's statement our first reaction here was one of outrageous indignation. But on thinking over it we find that it may not be as serious as it at first seems. Even in some ways it might not be regarded as a bad thing at all—central heating undoubtedly does add greatly to the value of a house and we learn that the valuation increase is relatively slight.

"In Britain the valuation laws are similar and there have been cases in which the valuation was increased following the installation of central heating. In this country there have been such cases too. In fact one case was contested and the valuation was reduced because of the fact that the particular installation was regarded as essential.

Enhances value

"One of the things which Mr. O'Malley's announcement has proved and which we have always endeavoured to point out to house purchasers is that central heating does enhance the value of a house. Within ten years it will hardly be possible to sell a house in which there is no central heating. Anyone who has lived in a house with central heating

Continued page twenty-three

COMBATS ATMOSPHERIC POLLUTION

with guaranteed 95%
efficiency at minimum cost



VOKES

Super-Vee*

Vokes Super-Vee is an inexpensive, expendable air filter which, because of its unique medium, can offer up to 25% greater capacity compared with similar filters of the same size. This medium, impregnated with a specially developed adhesive, combines high filtration efficiency (guaranteed 96% against Aloxite 50 Test Dust) with long life. Unaffected by moisture, non-cracking, and resistant to fungal growth, it is ideal for the collection of sooty or tarry deposits, without any danger of fiber migration. Vokes Super-Vee, which is fully interchangeable with other filters of its type, is already widely used in applications such as paint finishing plant, chemical laboratories, textile plant, distilleries and heating and ventilation installations. Write for details of how it can give you high filtration efficiency at lowest possible cost.

THE
LEINSTER ENGINEERING CO.
LIMITED
158-159 CHURCH STREET, DUBLIN

Big turnout for Potez Demonstration

MORE THAN 300 people, including many architects and builders, went to see the Potez central heating system installed by the Potez Heating Division of M. Rowan & Co., Ltd., 51/2 Capel Street and 1/2 Westmoreland Street, Dublin, in the Springfield Park (Templeogue) Showhouse.

The house was open for inspection for two days last month and Messrs. Rowan were very pleased with the response, said a company official. Their enterprise resulted in "a shower of inquiries."

This is a four-bedroomed house and the total cost of supplying and installing the Potez unit, a 250-gallon fuel storage tank, ducting and grills, was £150.

POTTERTONS ENTER THE RAD FIELD

THOMAS POTTERTON, makers of the well-known Diplomat boilers, are entering the radiator field.

They will be made by Fisher-Ludlow, of Birmingham, to Potterton specifications, whose name they will carry. The new radiator, of pressed steel panel design, was introduced at a reception in London.

They will be available there from May, in three heights—18, 24 and 30 inch—priced at 7s. a square foot for the smaller size and 6s. 6d. for the two larger sizes.

Heat emission is quoted at 182 B.t.u./hr. per sq. ft. for single panels and 155 B.t.u./hr. for double panels, outputs being based on 100 deg. F. differential between mean radiator and ambient temperatures.

NEW RANGE FROM WARMAC

WARMAC LTD., manufacturers of pressure units for high temperature hot water heating systems, of Salford, Lancs., have now developed a new range of standard high pressure units

TRADE

TOPICS

PLUMBERS DREAM OR NIGHTMARE!

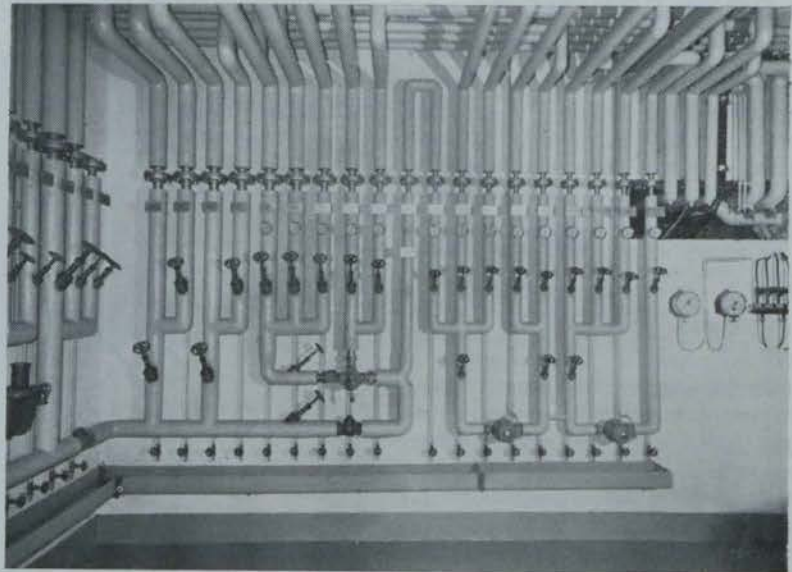

This photograph, supplied to us by Walker Crowweller & Co., Ltd., water temperature control specialists, is typical of the precision and neatness of

installers in many European countries. Taken at a private medical clinic in Switzerland, it shows the terminations of all the hot and cold water circuits which serve the building.

in addition to those units manufactured to clients' specific requirements.

The range is based on the highly successful P.4 series, and comprising 21 units. The standard range will cover H.P.H.W. installations up to 46,000,000 B.t.u. per hour load with system contents up to 18,000 Imperial gallons. The operating conditions of temperature and pressure will rise in four stages from a maximum 300°F. and 90 p.s.i.g. to a maximum 360°F. and 190 p.s.i.g.

Irish agent: Hugh C. Maguire, Esq., 37 Blackheath Park, Clontarf, Dublin.

ASCOT ISSUE A NEW BROADSHEET

A COLOURFUL new broadsheet has been issued by Ascot Gas Water Heaters Ltd., featuring their range of sink water heaters.

The broadsheet has been published to further the Company's policy of reducing to a minimum the number of sales leaflets on the Ascot range and the water heaters described in it are the G525/1, the G510/1 and the G515/1.

Walker Crowweller's interest in this installation is the Leonard T.202 steam/water thermostatic mixing valve (just discernable near the centre of the picture) used to control the temperature of the domestic hot water.

Exclusive Opportunity For Plumbing & Heating Engineers

Thousands of feet of standard tinned copper tubing to BS.659:1955, huge quantities of "Yorkshire" capillary fittings of many types, Saunders diaphragm valves, galvanised tanks with lids and stands, motor-driven water circulating pumps, fan cooled heat exchangers and many other heating and plumbing fittings. Also standard type domestic refrigerator replacement sealed units. ALL BRAND NEW and offered at WELL BELOW WHOLE-SALE PRICE. Send for illustrated list today.

Proops Bros. Ltd.

52 Tottenham Court Road, London, W.1. Tel.: LANGham 0141.

domestic water supply

JOINTS FOR PIPEWORK

Required

THE plumber often faces requirements that demand that joints in lead pipes shall be of the kind known as the wiped soldered joint, or some other joint equally good. The wiped joint is the most common, but the soldered spigot joint, which is very economical on solder, is accepted by many Water Undertakings for use above ground. It is very useful for bath and basin tap connections to lead pipe.

The wiped soldered joint is made by preparing the ends of the pipe, fitting them carefully together, fluxing the prepared joint area with tallow, and heating it with a blowlamp until it will accept solder, and "tin". Sufficient solder is then added to make the joint. This solder mass is heated until it melts and runs off into a "catch cloth" of moleskin held underneath the joint. The molten solder is then quickly transferred to the pipe joint area, and a moleskin "wiping cloth" is used to shape and wipe the joint to the proper shape while it is still a pasty mass.

Skilled

THIS is a skilled operation, and can be learned only with practice.

Our illustration shows two applications of a plumber's wiped soldered joint.



A. L. TOWNSEND
M.R.P., M.R.S.H.

The author, a lecturer at Oxford College of Technology, continues the first part of a four stage course on plumbing.

1. Mandrel. A cylindrical boxwood tool used to restore the cylindrical bore of the larger thin-walled lead waste pipes. The mandrel is given a light smear of tallow to lubricate its passage through the pipe. It is inserted into the pipe and driven through with a drive stick. The drive stick might be of wood or it might be a piece of gas barrel one end of which is threaded. On this end is screwed a socket filled and headed with lead; this will protect the wooden mandrel from damage.

Alternatively, a cap could be used in place of the lead filled socket and a piece of rag or cotton waste placed just behind the mandrel so as to protect it from the blows of the metal cap. A mandrel is not necessary for lead pipes used for water services as the wall thickness of these is such that the bore seldom becomes flattened or distorted.

2. Dresser. This would be used in conjunction with the mandrel to dress the external wall surfaces of the pipes.

3. Saw. To cut the pipe to length.

4. Rasp. To square the pipe end, and to taper the spigot end so that it fits snugly into the "bell" made by the tanpin in the end of the socket pipe.

5. Tanpin or Turnpin. This is a boxwood tool used to make a "bell" on the socket end of the pipe. It is a simple cone-shaped tool, and is

available in a wide variety of sizes to suit the many different sizes of lead pipe used in plumbing.

6. Cardwire. This is used to scratch clean the surface of the lead pipe before plumber's black is applied. Lead is a naturally greasy material, and the plumber's black, which is a water mixture, will not readily take to greasy surfaces.

7. Chalk or powdered chalk. This is applied to the cardwire surfaces in order to absorb any traces of grease that might be left.

8. Plumber's black, soil, or tarnish. This is painted on to the pipe over and well beyond the joint area. Solder will not stick to these blacked or "soiled" areas and so when the actual joint area has been cleaned of plumber's black, the edge of that which is left defines the joint area.

9. Shavehook. This is used to shave clean the areas to be soldered. The prepared "bell" end of the pipe and the rasped tapered end are carefully fitted together and the length of the wiped joint is marked. The ends are then dismantled and a pair of dividers or a pair of compasses are used to mark the length to be shaved on each pipe end. This is done by rotating the pipe and allowing the point of the adjusted compasses to mark round the pipe wall.

10. Dividers or Compasses are needed for the process just described.

11. Small bossing mallet or hammer. When the joint has been prepared and shaved ready for wiping, the two ends can be finally mated together. The "bell" of the socket pipe is dressed neatly and tightly to the wall of the spigot pipe so as to prevent solder

Continued overleaf

The Irish Plumber and Heating Contractor.

from previous page

JOINTS FOR PIPEWORK

from entering the pipe bore during the joint wiping operation.

12. Pipe Fixings. These may be special devices purchased from the tool stockists for the purpose, or they may be an ordinary sort of fixing. It is important that adequate fixing be provided before, during, and after the joint has been wiped, and until it is finally set solid.

13. Moleskin wiping cloths. These cloths are made of a tough material with "ribs" not unlike the "ribs" in corduroy, and are used to manipulate the molten solder. They can be made from moleskin cloth bought by the yard or they can be bought ready-made from tool stockists. Moleskin cloths should be taken great care of, and are best kept in a tin or bag, not thrown carelessly into the tool bag along with all the other pieces of equipment. When a wiper is getting nicely "broken in" it is also getting worn out. It is a good idea to have several wipers in different stages of breaking in. It is best to have a new one which you can start breaking in on less important work, and one well broken in ready to replace the wiper which is best at the moment but will soon become hopelessly worn out.

14. Blowlamp. Generally these are of the type which use paraffin fuel, but butane gas blowlamps are now becoming popular since they are easier to light, and are clean to use.

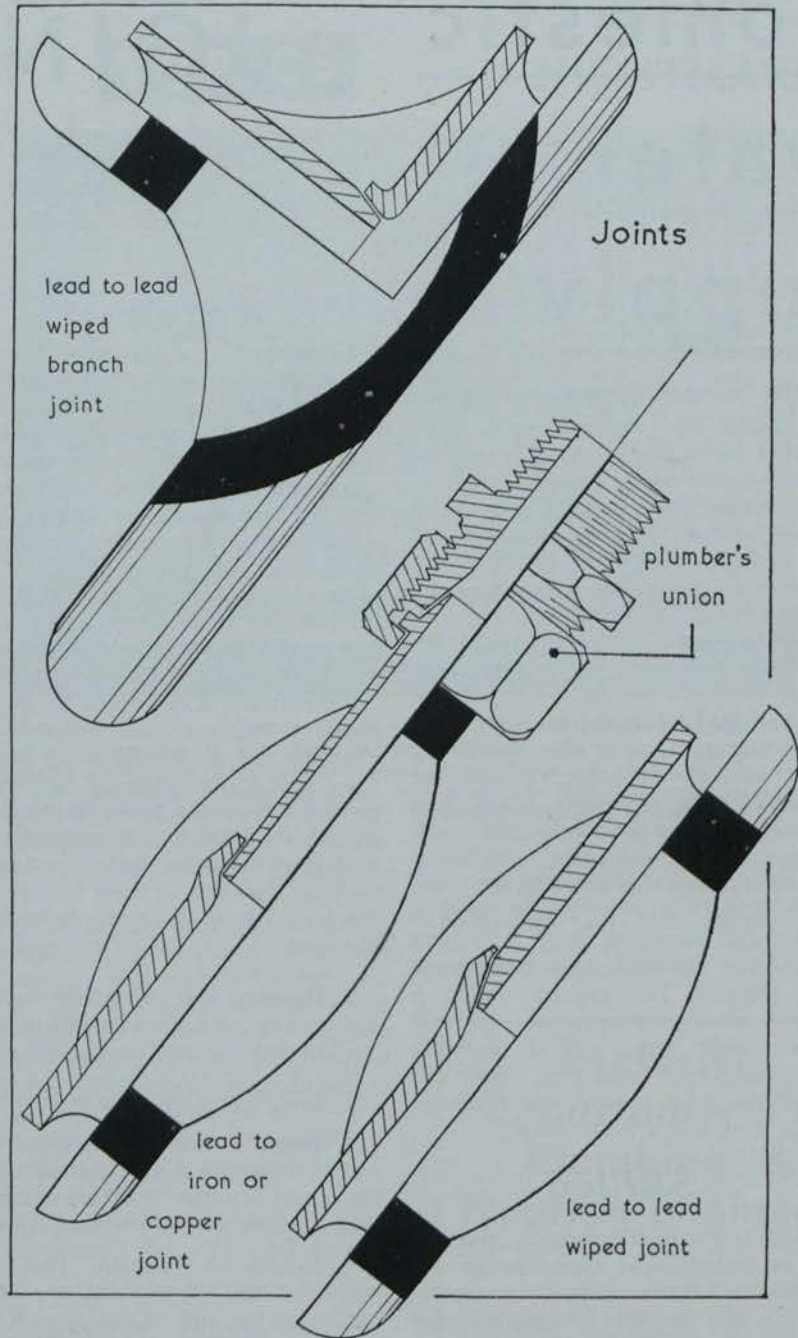

Joint lengths—wiped soldered joints

Internal pipe diameter	Joint length	Wiping cloth width
½" and ¾"	2½"	3"
1" and 1¼"	3"	3½"
1½" and 2"	3½"	3½" or 4"

solder joints which joint lead pipes end to end. (See illustrations).

Again, practice in preparation and wiping is the only way to gain the necessary skill, but our illustration shows the important features of a branch joint. They are as follows:

- (1) The bossed branch opening in the main pipe is carefully worked so as to avoid obstruction in the main pipeline;
- (2) the branch entry does not enter or obstruct the main pipeline;
- (3) the "cup" to receive the branch is

worked well up to ensure a good entry for the branch pipe.

Tools required

ALL the tools listed for the preparation and wiping of the underhand or the upright wiped plumber's joint will also be used for branch joints. The following additional tools will be needed.

- 1. Pipe opening tool.** This is some-

Text continued page twenty-eight

April, 1963.

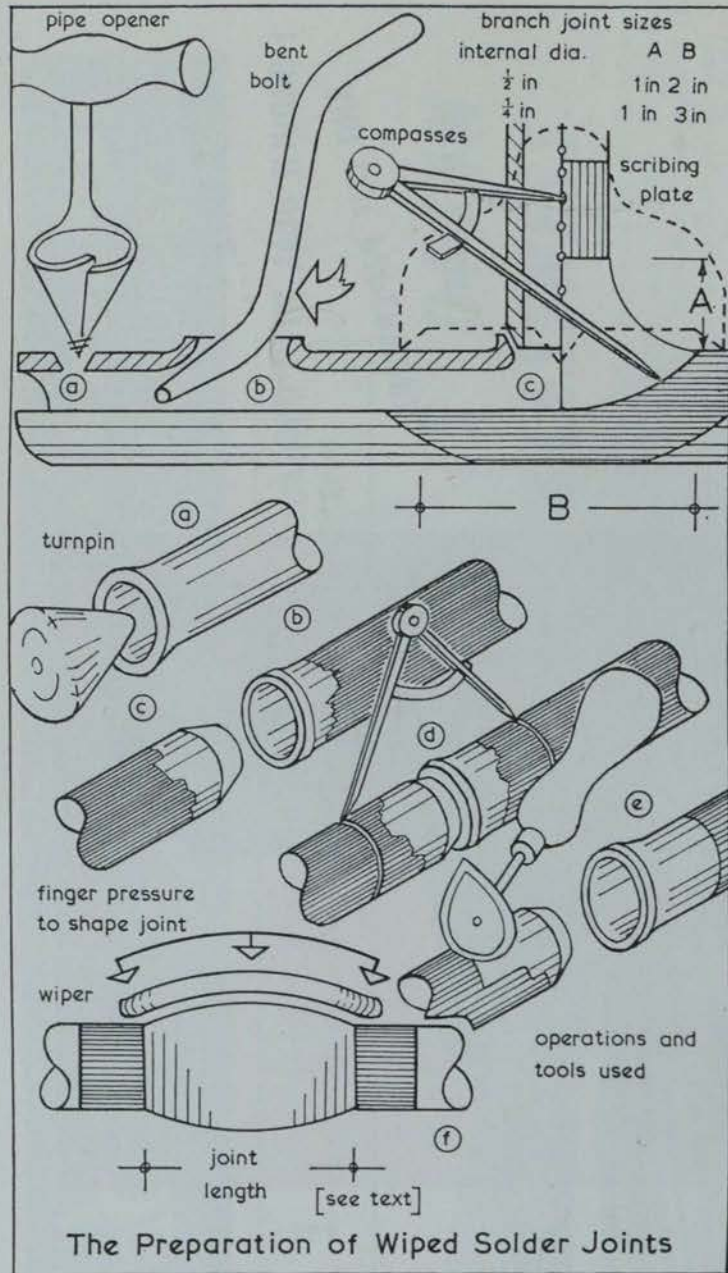

Joints for pipework

See text on
opposite page

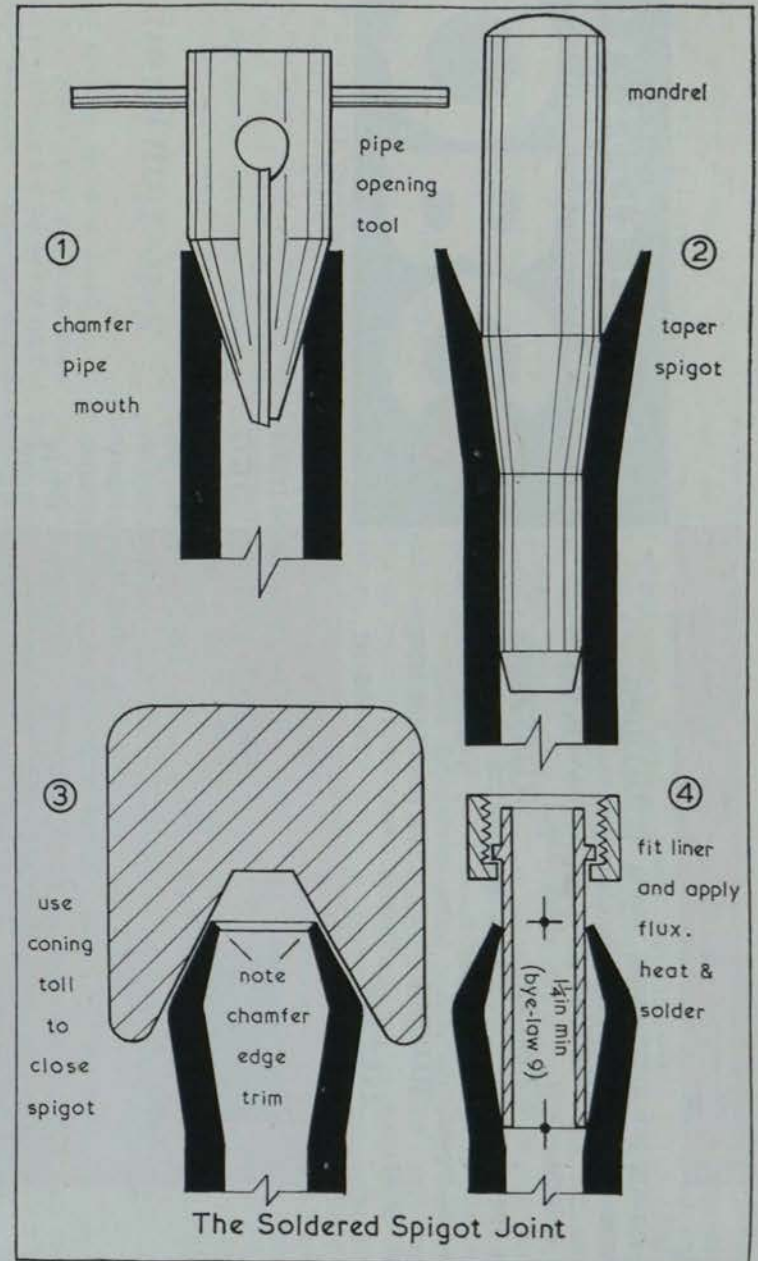

Nine

**BERT SAYS...
I SHOULD DEAL WITH OBC
AND CUT PAPERWORK...
BERT KNOWS!**



Seems that when you go to O.B.C. there's such a heck of a big stock . . . Bert says they've got the lot—everything you're ever likely to want—so, you don't have to write to half a dozen or more different firms—just buy it all at O.B.C. Makes a difference! Means only one lot of invoicing. It's something I've always wanted—to cut down the paper work. And another thing, Bert says their delivery service is right on the ball! It all adds up to something well worth finding out about. Quick, too. What about you? First thing—send for the new O.B.C. illustrated Catalogue. Do that right away.



OBC  LTD.

Largest Heating Equipment Merchants
G A S - S O L I D F U E L - O I L

DUBLIN
Phone: 61653 & 63061.

BOURNEMOUTH
Phone: Christchurch 1522/3

LONDON
Phone: RELiance 7971/2/3.

NEWCASTLE
Phone: 810857.

MANCHESTER
Phone: Oldham Main 9488/9/90.

DROITWICH, Worcs. (Head Office and Works)
Phone: 2551 (10 lines).

BELFAST
Phone: 31576.

BRISTOL
Phone: 293774/5/6

LEICESTER
Phone: 74908.

GLASGOW
Phone: DOUglas 5115.

CARDIFF
Phone: 28613/4/5.



AN IRISH PLUMBER & HEATING CONTRACTOR SPECIAL SURVEY

1 REVIEW OF WATER CIRCULATORS AND PUMPS, WATER PUMPING AND STORAGE EQUIPMENT.

PUMP TROUBLE IS OFTEN CAUSED BY CARELESSNESS

WITH the winter of 1962-'63 behind us, leaving a record as one of the coldest and severest for years, many people are now considering the installation of a central heating system before next year's recurrence.

Naturally, small bore or forced circulation will be the system chosen in many cases, although if the house is only being built, warm air systems may also be considered.

It is not intended in this short article to deal with design of heating systems; however, it may be interesting to mention to the readers of "The Contractor" some of the fundamental points to be observed in the installation of the circulating pump, which may well be classed the "heart" of the forced circulation system.

Complaints

Very often indeed complaints are voiced in the trade condemning manufacturers of pumps for faulty products. In actual fact the cause of the trouble is often the lack of care taken, in sizing the pump to the system, or more often still, the inefficiency or pure carelessness of the operative in fitting the pump. Manufacturers have gone to endless trouble to provide very descriptive literature giving full and detailed instructions for the installation of pumps. However, it is found when investigating a complaint that the pump was fitted upside down, even though there is a well defined arrow indicating the direction of flow.

For many years it has been accepted that a small bore pipe using a forced circulation would be just as

effective as a larger pipe, using the Gravity system, but until recent years heating engineers had not really considered installing circulation pumps in the smaller type house, due, mainly, to the excessive cost of a pump in proportion to the total cost of the installation.

The noise factor was another reason, which certainly meant that the pump could not be fitted anywhere inside the house.

Advantages

With the advent of such a wonderful array of small pumps, the heating designer was able to turn his attention to the small bore pipe, thereby giving a remarkably neater appearance than the large and heavy pipes necessary in other days. As the heating mains are so small in diameter, usually half inch, it is unnecessary to conceal them, provided they are neatly clipped to the skirting boards.

Again, the use of a circulation pump allows a greater flexibility in lay-out, the actual cost is reduced, and costly structural work is eliminated. Another great advantage is the quick heating up from cold, due to rapid velocity of water through the pipes.

Type of pump

From this development of systems calling for a small, efficient circulation pump, manufacturers, induced by keen competition from each other, put on the market a very comprehensive range of small pumps suitable for all domestic systems.

The majority are all of the "Canned Rotor Type." This means

that they have no gland between the motor and impeller, so eliminating water leaks from loose packing glands—a common fault on the early types of pumps. The major advantage of these pumps is that the bearings are water lubricated—no oiling or greasing is required. The motor is of the squirrel caged induction type, and gives running costs that are negligible (about the same as those of the average 60 watt lamp).

The pumps are super-silent in operation. So silent, in fact, that it is difficult to discern if they are, in fact, running. Certainly the advent of these pumps eliminates the noise factor, which could be a constant source of annoyance in a small house. In fact, if the pump is noisy, it needs repair.

Selecting pump

In forced circulation systems having more than one circuit, the total head of the index circuit only, and the volume of water which has to be circulated to satisfy all heating circuits are considered, to determine the duty of the pump. It must be remembered "Total length" = length of circuit plus necessary allowance for fittings.

The index circuit is taken because it offers the greatest resistance to the flow of water, so if the pump head is sufficient for this circuit it is suitable for all circuits.

When the necessary calculations have been made, regarding loss of head and quantity of water circulated,

Continued overleaf



This special survey—another in a series on important aspects of the plumbing and heating trades—has been compiled by technical expert Brendan Rooney.

from previous page

Many advantages with pumped circulation

WHAT MORE DO YOU WANT...

in a heating circuit than a SELFLO accelerator and a WYTHON calorifier? Silence, elimination of pump maintenance (it's glandless), and storage calorifiers built to BSS 853. These are the qual-

ities which have already made them popular with Heating Engineers. Do they solve your problems.

More information on these pumps and calorifiers is available on request.



HOLDEN AND BROOKE LTD
SIRIUS WORKS
MANCHESTER 12



REPRESENTED BY:

Irish Republic
G. C. Pillinger & Co.
(Ireland) Ltd
20 Sycamore Street
Dublin
Telephone: Dublin 77007
also 35 South Terrace
Cork
Telephone: Cork 23055

Northern Ireland
J. Hind & Sons Ltd
Rowan Engineering
Works, Prince Regent
Road Castlereagh
Belfast. Telephone:
Belfast 59365

an addition of 20% should be added to the calculated pump duty. It is not recommended to select a pump that has a head capacity much greater than is required by the system, otherwise there is the possibility of noisy operation.

Pump installation

The pump may be fitted in either flow or return mains, according to circumstances, but whenever possible it should be located on the return main, so that it operates at a lower temperature; again it is an advantage to have the pump at the lower level, for ease of inspection.

In certain circumstances, such as in bungalows, where the heating mains are just below the expansion tank, it may be necessary to fit it in the flow main so as to avoid the likelihood of sub-atmospheric pressure in the high level mains.

With the correct size pump selected for the job, it is now only a matter of following the maker's instructions; they are brief and simple. Sometimes it is advisable to give the pump a run of a few seconds to check for direction of rotation, although it is emphasised that this should be only for a few seconds, as there will be no lubrication of the bearings.

Essential

Again, it is essential to ensure that a system is free from all grit, metal filings, etc., which could affect the operation of the pump, and cause the bearings to wear excessively. It is advisable, therefore, that a thorough flushing of the system be carried out before fitting the pump. It is also sensible to instal the pump in such a position that the working parts can be withdrawn without the need for complete removal of the unit from the pipe line.

In discussing pumps for heating systems one could go on and on, such is the variety, the simplicity of design, and the ingenuity of the manufacturer in introducing unusual metals to eliminate corrosion. It can be truthfully said, however, that the pump in

Continued page fourteen

THE MOST COMPLETE LINE OF PUMP AND AIR VOLUME CONTROLS

Type 160 pressure switch, range 15 to 65 lbs., for all types of domestic water systems. Available in convenient Twin-Pak... 2 switches individually packed in one carton.

Series 158 sump pump switch... single pole with dust-proof, tamper-proof switching unit. Operated by "weights"... no troublesome floats, rods or guides... better performance.

Series 190 air volume controls for shallow and deep wells. Models are available with or without built-in pressure gauge or gauge tapping.

Type 196 air volume control for vertical tanks, both buried and surface types, of deep well water systems. Models with or without minimum pressure release valves.

Type 194R Supercharger gives positive air charging with all jet and centrifugal pumps... ideal for submersibles.

IF you install, service, distribute or manufacture water system equipment... it simplifies your job to buy all your pump and air volume controls from one experienced and dependable source...

MANOTHERM LTD.,

14 CORN EXCHANGE BUILDINGS, BURGH QUAY, DUBLIN. Tel. 73913.

The Irish Plumber and Heating Contractor.

SPECIAL SURVEY

from page twelve

a heating system can be truly compared to the human heart—it has to work perfectly, with no leaking, or sticky valves, otherwise if it fails the whole plant is out of commission.

While, so far, we have considered pumps in relation to central heating systems, it is obvious that there is ever a larger field for the use of cold water pumping units.

It is regrettable that more publicity is not given to the fact that substantial grants are available from Government Departments to people who provide water supplies for their own homes. Even without grants, many people are willing to invest capital for a good supply of water.

With automatic pressure pumps, copper pipes and plastic pipe in "mile" long runs, manufactured in this country, it would need no great effort to emphasise the need for a city type water service in rural homes.

This subject of cold water pumping has been dealt with in great detail in recent issues of the "Contractor" and interested readers could, with profit, examine some of the suggestions put forward then.

In connection with this Special Survey we review here products from the leading manufacturers' ranges. All claims are those of the manufacturer.

AQUADARE JET PUMPS and Automatic Pressure Systems are designed for the handling of clean cold water and may be used to pump from deep or shallow wells, boreholes, lakes, rivers, streams, etc., for domestic, agricultural, industrial or horticultural water supply. They may also be used for the boosting of mains pressure.

All pumps are available with optional electric motor or separate 4-stroke petrol engine. Five models are available, which can be arranged to operate from shallow or deep wells, boreholes or other sources.

The smallest model is capable of providing adequate water for a cottage, house or small establishment, and arranged for deep well operation, is capable of a total lift of 45 feet. The larger units have a greater output and can operate from deeper boreholes, down to a suction lift of 160 feet.

An electrically driven pump raises

water and delivers it into the galvanised tank which has a cushion of air automatically maintained by the air volume control, operating in conjunction with the pump. As water is drawn from the tank, the water level and pressure drop until a point where the pressure switch automatically restarts the motor. When the tank is replenished, a switch cuts out the motor. A reasonable amount of water may be drawn before the switch operates.

The systems are simple, trouble-free, quiet running and built to give long service at low cost.

★ ★ ★

WORTHINGTON - SIMPSON introduce a range of hot water circulators for use in the heating systems of factories, hospitals, office blocks and other large commercial and public buildings.

These pumps will be offered at very competitive prices and installation and

Continued page twenty-five

What's Our Line?

... a good question to ask the largest machinery stockists in Ireland. In actual fact, we have literally hundreds of lines but here are a few that we think will be of interest to you.

INDUSTRIAL & DOMESTIC PUMPS - BOILER FEED PUMPS - CIRCULATORS - TUBING & FITTINGS VALVES - PIPE BENDING MACHINES - PIPE TOOLS - GAS & ELECTRIC WELDING PLANT AND ACCESSORIES - ELECTRODES - SPOT WELDING EQUIPMENT - HAND TOOLS.



RIDGID
WORKSAVER PIPE TOOLS

Used by leading firms and public authorities everywhere. A comprehensive range of Ridgid tools is always available from stock and every sale is backed by efficient after sales service and complete stocks of spare parts.

MUREX WELDING EQUIPMENT

Over 100 different Murex electrodes are available for welding steel and non-ferrous metals. Murex electrodes were exclusively used for the construction of Britain's first nuclear submarine—the "Dreadnought".



CIRCULATING PUMPS



Noiseless circulators for central heating installations by the famous Dutch pump manufacturers—Stork of Hengelo. Ratings from 1/50 h.p. to 2/3 h.p. Enquiries invited.

**S
T
O
R
K**

HENDRON BROS. (DUBLIN) LTD.

BROADSTONE DUBLIN, 7.

PHONE 41116-7-8-9.

UNIVERSAL FABRICATORS LIMITED

STORAGE TANKS UNLIMITED

for fuel oil
kerosene
petrol
also

PRESSURE VESSELS
PIPELINES
WELDED PLATE
STRUCTURES
to
A.P.I. & ASME
specifications

Sales Distributors
Carthorn (1949) Ltd

Commercial Buildings, Dame St., Dublin 2



When a plumber is looking for a



pump...

... for CENTRAL HEATING

he cannot buy better
than the

SIGMUND THERMOPAK or SILENTFLO

and the prices are very competitive. Why not buy the best at practically
no extra cost?

SPECIAL FEATURES:

- Super Silent and self-lubricating.
- Being glandless, is free from leaks and needs absolutely no attention whilst operating.
- Special silicon-impregnated winding—no starter protection needed.
- Precision-ground sleeve bearings—for long life.

PRICES AND ILLUSTRATED LITERATURE SENT ON APPLICATION.

ONLY AVAILABLE FROM THE SOLE AGENTS FOR REPUBLIC
OF IRELAND:

MONSELL, MITCHELL & CO. LTD.

67-73 TOWNSEND STREET, DUBLIN 2.

Phone 76282



FULLY GUARANTEED
AND COMPLETE AFTER
SALES SERVICE AVAIL-
ABLE.

The Irish Plumber and Heating Contractor.

PLASTICS IN PLUMBING



WE HAVE SECURED SERIALISATION
RIGHTS OF THIS IMPORTANT WORK BY
W. J. WOOLGAR
F.R.S.H., A.M.I.P.H.E., F.I.O.P., R.P.,
a former lecturer in charge of sanitation and
plumbing courses at the Northern Polytechnic.

Plastics and their make-up

IT is most essential in the study of any craft or trade, or indeed of any profession, that one should thoroughly understand one's materials and the principles of applying them. The plumber has for many years had to study the chemical and physical properties of the traditional materials of his trade in order to appreciate the ways in which they may most appropriately be used.

For example, it is virtually impossible to boss sheet lead or bend lead pipe without an understanding of the physical characteristics and properties of the metal; and these certainly have a bearing on the kind of jobs for which lead would be chosen. Similarly, in order to understand the properties of plastic materials, one must be aware of some of the chemical bases which underlie their structure.

Plastics represent a departure from the age-old practice of using materials more or less as they have been provided by nature. A modern chemical industry has changed this pattern by making available a whole range of new products, among which plastics form a distinct group.

"Plastic"

THE word "plastic" came into being as a general description for many materials of a like nature, such as celluloid, casein, and bakelite. The adjective merely signifies that the material is capable of being moulded into shape, as plasticine is moulded by children. In this sense the word is not a suitable description for the many materials that have since been evolved, and as such it has

industry. Various titles have been suggested to overcome the difficulty, but now the industry has agreed that the word "plastic" shall be used, as the most logical name for the very wide range of materials that it has to cover.

The term describes a group of man-made, organic chemical compounds which can broadly be divided into two types—"thermoplastics" and "thermosetting plastics." Thermoplastics soften when heated and harden on cooling; they can afterwards be softened again provided that the heat applied is not sufficient to cause them to decompose. Among the thermoplastic materials used in plumbing work are polythene, polyvinyl chloride (P.V.C.), polystyrene, polypropylene, acrylics (perspex), nylon, and fluorocarbons. Thermosetting plastics are those which soften when first heated for moulding, and which then set or harden into a permanent shape which cannot afterwards be altered by the application of further heat. These are frequently called thermosetting resins, and the most important of them are formaldehyde, phenol formaldehyde, and polyester resins.

Flow freely

GENERALLY, plastics under heat and pressure act like liquids and flow freely, but they always retain the structural character of solids. This is because they are composed of giant molecules; that is to say, of molecular chains of great length, made up of many atoms, which under heat and pressure simply slide over one another, so that the mass changes shape. In order to appreciate this

it is necessary to understand the chemical structure of matter.

All matter is made up from atoms, the smallest units that can exist in a stable state. Normally, atoms are joined together in numbers varying according to the substance, and form units called molecules. Molecules may contain atoms all of one type, in which case the material they make up will be an element, such as lead. If molecules contain atoms of more than one sort—that is, if they contain a mixture of elements—the substance they make up will be a compound, a more complex structure. For example, a molecule of water is made up of the elements hydrogen and oxygen. The elements combine in this case in a proportion of two to one, and the chemical formula for water may be written:



THE fact that water is made up of hydrogen and oxygen in the proportion of two to one is immediately obvious to the chemist from this formula, which represents one molecule.

The combining power or valency of the atoms which unite to form a molecule are represented by lines. Hydrogen has a combining power of one (H-) and oxygen of two (-O-). The equation for the formation of water therefore reads:

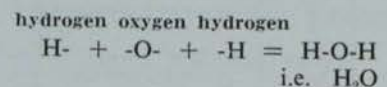

THE elements are known by symbols—usually the initial letter of their name. Thus carbon is represented as C, nitrogen as N,

AUTHOR'S NOTE

THE introduction of certain plastics materials into plumbing, to supplement and take the place of the older and more established materials, has been inevitable because of their eminent suitability for plumbing purposes. The plumbing industry will inevitably have to accustom itself to the idea of using plastics, and must recognize that they are here to stay.

It should be appreciated that we owe our present knowledge of this application of plastics materials to the plastics industry, which has accumulated in the past few years a vast knowledge of polymerization and copolymerization.

Because so many combina-

tions of so many materials are possible, an enormous variety of plastics can be produced, all with different properties and characteristics. Indeed, it seems certain that we are only beginning to grasp their potentialities, and that as further research and experiment is carried out, and more knowledge becomes available, new and exciting applications of plastics to plumbing will be found.

BASIC KNOWLEDGE

IT is well known that the skill with which a craftsman can handle his material is largely dependent on his having an intimate knowledge of its properties. While the plumber is in no way

expected to be a chemist, he should have at least a basic knowledge of the chemistry of the material with which he is dealing. Hence I have introduced this monograph on plastics in plumbing with a simple explanation of the structure of plastics as it is generally understood, together with the necessary chemical details.

I am indebted to the following firms, who have been kind enough to provide me with information and illustrations: Yorkshire Imperial Metals Ltd.; Messrs. Folkard Ltd.; Formica Ltd.; Ekco Plastics Ltd.; Kay & Co. Ltd.; Greenwood & Hughes Ltd.; The Marley Tile Co. Ltd.; Burn Brothers (London) Ltd.

from previous page

oxygen as O, and hydrogen as H. Since calcium and carbon both begin with C, calcium is known as Ca, and there are other small variations of this sort.

Each element has an atomic weight, based on a system which has hydrogen as unity.

Molecular weight is simply the sum of the weights of the atoms contained in a molecule. As has already been said, molecules of plastics are particularly large, and are made up of large numbers of atoms.

The basic constituent of plastics is carbon, and chemically it has four lines with which it can combine with other elements. For example, one atom of carbon can combine with four atoms of hydrogen:

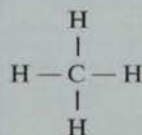

producing methane gas, which is written CH₄. The gas ethane (C₂H₆) is a combination of two atoms of carbon and six atoms of hydrogen:

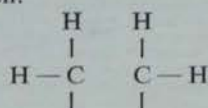

while ethylene (C₂H₄) is arranged:

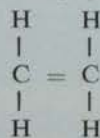

Each carbon atom can combine with four other atoms, and hydrogen with one. In the case of ethylene, therefore, the capacity of each hydrogen atom is satisfied, but only three of the four hooks of the carbon atom are used up, as it were, in connecting with each of the two hydrogen atoms and the other carbon atom. The fourth hook of the carbon atom makes a double bond with the other carbon.

Double bond

IN suitable conditions this double bond can be opened out and the carbon atoms used to join ethylene molecules together like this:

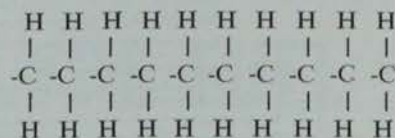

In this way atoms of the gas ethylene can form a chain. This shows the characteristic of plastics as a group; that they form long

chains, made up of large molecules. In this case ethylene is the monomer forming a chain or polymer. The process is called polymerization, and during it a change in properties also occurs. In the example chosen the change is from the gas, ethylene, to a polymer consisting of wax-like granules. The polymer is polyethylene, which is usually abbreviated to "polythene."

By changing the starting material—that is, by substituting other atoms for certain of the hydrogen atoms—a different monomer result can be obtained. For example, if a chlorine atom is substituted for a hydrogen atom, the chloroethylene or vinyl chloride monomer is obtained:

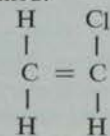

The vinyl chloride polymerizes as follows:

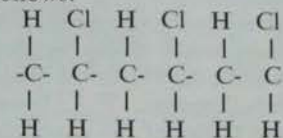

Continued overleaf

The Irish Plumber and Heating Contractor.

LAUNCHING DOMESTIC SHOWER PROMOTION CAMPAIGN

FOLLOWING their successful introduction to the trade last year of the "Mira" dual control, shower mixing tap, Walker Crowweller & Co. Ltd. are now launching a large-scale consumer promotion campaign for domestic showers.

The firm, noted for many years as one of the world's leading specialists in water temperature control, has deliberately withheld fostering the domestic shower market until it had a product which, it felt, not only pro-

vided the ideal form of control, but also was suitable for use under most of the varying plumbing conditions likely to be encountered in this field, said a spokesman.

At about the same time, Walker Crowweller also introduced the "Leonard 72" thermostatic mixing valve, which also combines flow and temperature control in one unit and is ideal for showers and similar purposes in larger dwellings, industrial, commercial and institutional build-

ings, where the advantage of thermostatic control is essential. The Leonard 72 requires a minimum head of five feet and generally a higher standard of installation conditions.

With the Mira and the Leonard 72 as basic forms of control, the firm has devised five different combinations of controller, risers and shower roses which it is now offering to the general public as complete shower "packages," necessitating only installation and connection to the hot and cold supplies.

Irish agents: Modern Plant Ltd., Crumlin Road, Dublin.

from previous page

PLASTICS IN PLUMBING

THERE are many possible variations on the theme of substituting different monomers, and these produce a large range of materials. Furthermore, different monomer units can be combined, producing "copolymers." This process is called "addition polymerization," and is one way of forming large molecules for use as plastics. Other methods are available for building polymers, and are used, for example, in the manufacture of "bakelite" and nylon. However, since polythene and P.V.C. are the most interesting to the plumber, I have concentrated on the process which underlies their manufacture.

Extracts from British Standards 1972: 1961 Polythene Pipe (Type 425) for Cold Water Services, 3284. 1961 Polythene Pipe (Type 710) for Cold Water Services, 3505 : 1962 Unplasticized P.V.C. (Type 1140) for Cold Water Supply, 3506. . 1962 Unplasticized P.V.C. for Industrial Uses, are reproduced by permission of the British Standards Institution, 2 Park Street, London, W.1, from whom copies of the complete Standards may be purchased.

<https://arrow.tudublin.ie/bsn/Vol3/Iss1/1>
DOI: 10.21427/D7BQ42
Eighteen

Your Boiler Engineer visits us — and we return the compliment

Why should your boiler engineer visit us? Perhaps to take advantage of the unique service offered by John Thompson (Wilson Boilers) Ltd., manufacturers of the famous MULTIPAC Wet Back Package Boiler: a free two day course at our Glasgow training school on the best methods of operating and maintaining your MULTIPAC Boiler to obtain maximum efficiency and trouble-free usage.



Why does our boiler engineer visit you? Because John Thompson are the only boilermakers who operate a genuine 24 hour maintenance service in the United

Kingdom and Eire for all boiler ancillaries—including burner replacements. In addition to answering emergency calls, our teams of specialist engineers at



Glasgow, London, Manchester, Birmingham and Belfast, make three annual visits to your premises to carry out a rigorous inspection of all working parts, controls and burner units.

If you would like more proof of the sound economic value of the MULTIPAC Maintenance Service, please contact us at any of the following branches:—

BELFAST: 16/20 Rosemary Street, Belfast.
BIRMINGHAM: 2 Greenfield Crescent, Edgbaston, Birmingham 15.
GLASGOW: 79 West Regent Street, Glasgow.
LONDON: Tavistock House East, Woburn Walk, Tavistock Square, W.C.1.
MANCHESTER: Sunlight House, Quay Street, Manchester 3.

- Is of the well proved 3 pass design.
- Has dished wet back combustion chamber, (no refractory troubles).
- Easy access to all parts of boiler for maintenance.
- Uses patented Primary Split Burner Quarl for ease of replacement.
- Only boiler with burner panel overriding control (i.e. Boiler can be kept steaming on hand control though panel "Automatics" are unserviceable).
- Ladder & gangway is fitted as standard.
- Sequence slowdown controls fitted for safety in operation.
- No need for costly pumping and heating sets (if O.S. tank is local to boilerhouse).
- Boiler accessories are of uniform manufacture and only the finest are fitted.
- Boilers are rigorously tested under all operating conditions before despatch.



There's a 'MULTIPAC' installation in your area — contact our nearest branch office and we will arrange for you to see it in action.

JOHN THOMPSON PACKAGE BOILER DIVISION LILYBANK WORKS LONDON ROAD GLASGOW E 1



INVITATION . . .

We extend a hearty invitation to our many friends in the plumbing trade and all those interested in modern kitchen and bathroom furniture and fittings to visit our extensive showrooms.

Compression Joint Fittings - Copper Piping - Pipe Wrap - Copper Cylinders - Open Top Tanks - Pressed Steel and Cast Iron Radiators - Oil Fired and Solid Fuel Boilers - Baths, Basins, Toilet Sets, Shower Fittings - Mixer Fittings - Stainless Steel, Enamel Steel, Fire Clay Sinks - Blow Lamps, Solder - Eathroom and Kitchen Furniture - Double Compartment Tanks. For a full comprehensive supply of plumbing materials:

DOCKRELLS of Georges St., Dublin

TRADE ENQUIRIES INVITED.

CLYDE

GEN-O-THERM OIL-FIRED AIR HEATERS

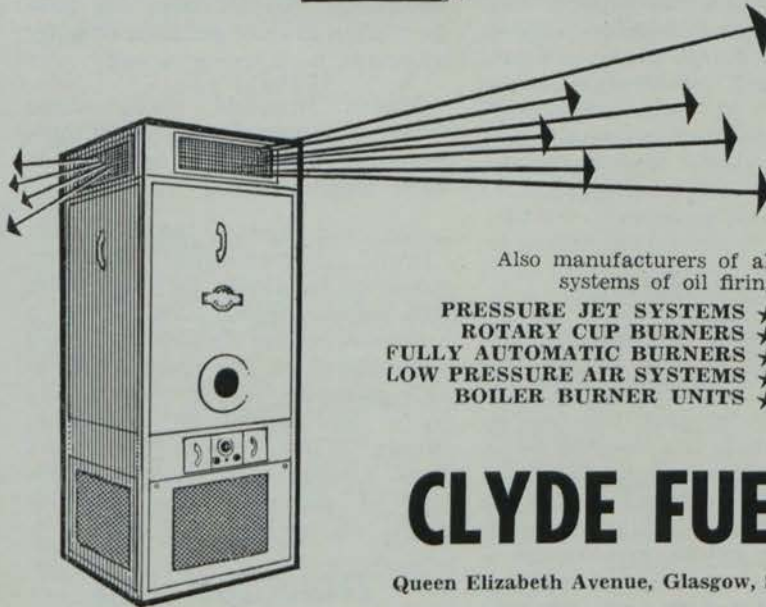

VERTICAL UNITS

These free-standing units (illustrated) are ideally suited for large buildings. Occupying small floor space and being self-contained, installation costs are very low. Using light diesel or gas oils, these units can be arranged with either independent or fully ducted systems.

HORIZONTAL UNITS

Designed for fully ducted systems with independent air circulating fan and burner, these units are supplied for ratings of 450,000 units to 4,500,000 B.T.U.'s per hour. The units are generally supplied for heavy fuel oils, but the smaller models are available for light diesel or gas oil.

Also manufacturers of all systems of oil firing

- PRESSURE JET SYSTEMS ★
- ROTARY CUP BURNERS ★
- FULLY AUTOMATIC BURNERS ★
- LOW PRESSURE AIR SYSTEMS ★
- BOILER BURNER UNITS ★

Write for full details to:

CLYDE FUEL SYSTEMS LTD.

Queen Elizabeth Avenue, Glasgow, S.W.2. - 6 Mount Street Crescent, DUBLIN 2. Tel. 66489.
80 Holywood Road, BELFAST 4. Tel.: 656365 - Hardcock House, 30/31 Marlboro Street, CORK. Tel.: 21729.

Service Centres: Londonderry, Armagh and Limerick.



REVIEW OF WATER TREATMENT CHEMICALS AND SOFTENING PLANTS

WATER TREATMENT NECESSARY

NATURALLY occurring waters are never pure. Even rainfall absorbs gases and dust from the atmosphere through which it falls. Thus, rainfall, the prime source of all natural waters, is not pure H₂O but H₂O + other substances which it dissolves or takes up in suspension as added impurities. The nature and extent of impurities in water will be influenced by the kind of ground on which rainfall is collected, or through which it percolates before collection and subsequent withdrawal for use.

Impurities in water fall into two groups, namely, matter in solution and matter in suspension. These are further divisible into organic and inorganic substances.

Water treatment is necessary to render a raw natural supply potable, or fit for human consumption.

In public, and privately operated, water undertakings, such treatment will usually include filtration to remove suspended matter, both organic and non-organic, and, in later stages, to provide a large measure of bacteriological purification. It has been shown that something like 25% of pathogenic organisms are removed by well operated sand filtration.

Settlement

SETTLEMENT will assist precipitation of suspended matters and thus reduce load on sand filter plant. The addition of chemical coagulants—sulphate of aluminum is commonly used—will assist the "floc" formation of

minute particles to larger ones more likely to precipitate.

Chlorination by automatic dosing plant will generally be used as final bactericide. Chlorinators permit of remarkably fine adjustment of dosage and used in conjunction with Chloroscope examination at frequent intervals, ensures adequacy of dose without inherent taste nuisance from over-dosing.

Paterson Engineering Co. Ltd., of Windsor House, Kingsway, London, are well known in this important field of water treatment. They produce all kinds of equipment, from rapid gravity filter installations, pressure filters, lime-soda softening plants, base-exchange softening plant, chlorinators, ozonisers (another form of bacteriological treatment employing electrical energy to create oxidising conditions in water), activated carbon filters (for taste control), and swimming pool waste treatment plant. They will gladly send descriptive literature and advice on problems of water treatment generally.

Drinking

GENERALLY, dissolved inorganic substances in water do not affect its potability or fitness for drinking. The water undertakings therefore are more concerned with removal of organic impurities which could be harmful to man if taken into the digestive system. Those inorganic substances in solution, troublesome as they may be either as corrosion or "furring" potentials, are therefore generally not removed by public utility treatment. If any particular

consumer wishes to remove these impurities for industrial or enhanced domestic comfort purposes, then a wide range of waste treatment equipment is available.

Private bacteriological treatment of water should be undertaken only after seeking informed opinion as to how it be done and how frequently tests for purity should be undertaken.

Such private water supply treatment, well waters for example, might employ the self sterilizing candle type filter as made by Berkefeld Filters Ltd., Tonbridge, Kent. These filters will correct turbidity due to matters in suspension in water and produce a clear water supply. Bacteriological purification is also effected, it being understood that all steps will have been taken to avoid pollution of water at source, be it spring or well.

Messrs. Berkefeld gladly advise those who might have need of such treatment equipment for small private water supplies.

An alternative, though more "fussy," bacteriological treatment would be by dosing the raw water with sodium hypochloride. This is a chlorine bearing chemical compound administered to the water in carefully graduated, regular doses, usually by a feed pump of some kind. Messrs. Wallace Tiernan of Power Road, London, W.4, specialise in this kind of treatment plant and will gladly advise prospective users.

Discolouring

MINERALS in solution affect the suitability of water for different



This special survey—another in a series on important aspects of the plumbing and heating trades—has been compiled by technical expert A. L. Townsend, M.R.S.H., M.I.P.

from previous page

uses and materials used to store or convey it. Iron in solution, for example, will discolour water and interfere with the working of base exchange water softeners unless these have been designed for use on such water. Aeration of the supply will usually precipitate the iron content. "Deminevalit" pre-softening plant equipment by the Permutit Company of Gunnersbury Ave., London, W.4, may be used either to reduce mineral exchange in the softener or to provide iron free water whether softeners are in use or not.

The **ph value** of water is an indication of its acidity or alkalinity. A ph value of 7 indicates a neutral water in this respect. 7 + ph values indicate alkalinity which will not have corrosive effect but may produce a hard water, i.e., one with which it is difficult to form a lather with soaps. Ph values of less than 7 indicate acidity in water and, according to lowness of the figure, suggest corrosive tendencies especially of ferrous materials in pipes, cisterns, etc. Such waters would also be more likely to give rise to electrodytic corrosion and to dezincification of brass ware.

Acidity

ACIDITY can be reduced by lime dosage, whilst hardness can be removed by base exchange water softeners.

Bare Exchange water softening plant for domestic or industrial use is available from several firms specialising in this and other water treatment plant.

The latest domestic Permutit model is square on plan and of kitchen unit standard working top height. The casings are wholly in glass fibre—a completely corrosion free material—and contain not only the softener itself, but also a supply of brine for the essential periodic regenerations of the base exchange material. This process of regeneration, not a difficult business but obviously requiring some

time and attention with ordinary domestic softeners, is automatically attended to in this particular model. The housewife merely keeps the brine tank replenished with salt and the electrically generated programming device operates the entire sequence of regeneration as soon as it senses that this is necessary.

Not necessary

WATER SOFTENERS are generally regarded as luxury items of kitchen equipment. In hard water districts this is far from true, and doubters would do well to find out just what comfort and economic advantages a suitable water softener offers. Stockists will gladly demonstrate and doubts are soon dispelled. One quickly recognises that the troubles associated with hard water usage need not be endured. More important still, it becomes clear that, far from being a luxury, a water softener is really an economically essential item of kitchen equipment.

The forward looking plumber with an eye to business, will thoroughly investigate the principles of softener operation and the advantages they offer the harassed hard water user. Thus armed, they are better able to talk "water softeners" to clients and perhaps make a sale. The discount is well worth while and the installation job likewise. Clients will long remember the wisdom of that plumber who introduced them to the delights of a softened water supply. Models are available to suit all waters, all quantities of water to be treated, and all pockets. Extended payment plans operate so that one can enjoy the benefits of soft water whilst paying for some out of income.

The "**Aquastat**" water treatment plant by Aquastat Ltd., Romney House, Tufton St., London, S.W.1, "softens" water by quite a different principle than that of the base-exchange plant.

The hard water is allowed to flow

through the Aquastat appliance, where it is subjected to very tiny but carefully pre-set electrical discharges. The effect of this upon the scale forming salts in solution is a physical one and not electro-chemical as in base-exchange water softening. The physical effect is an interference of the normal crystallization of the salt on precipitation. The result, simply expressed, is that instead of the precipitated scale being crystalline and interlocking into solid mass, each precipitate is rounded and will not therefore interlock into a solid immovable scale deposit. Instead the "mobile" precipitates settle and can be washed out of the system. In most cases the precipitates, in minute quantities, pass off to service with the water as it is drawn.

Electric current

IT would be true to say that such equipment is designed to prevent hard scale accumulations in boilers and pipelines, rather than that it softens water. The equipment does not reduce hardness in water, as base-exchange softeners do, but it does so change the physical character of the dissolved hardness, forming salts so that no scale encrustations, so costly to remove, occur.

The equipment uses ordinary electric current in minute amounts, takes up very little space, and is inexpensive to buy and operate. It is ideally suited to the treatment of boiler feed waters, domestic hot water calorifiers, bottle washing plant and like applications.

Aquastat Ltd. will gladly furnish details of dimensions, capacities and prices, together with illustrations of several large and small installations benefitting from this modern form of water treatment plant.

Aqua-Clear, by Kinnis & Brown Ltd., 54/62 New Broad St., London, E.C.2, is another form of scale and corrosion inhibition water treatment.

Continued overleaf

The Irish Plumber and Heating Contractor.

This uses a secret chemical compound of twelve active elements dosed to the water usually at the rate of one part chemical to one million parts water. The chemical is available in liquid and crystal forms. The liquid is for use in closed water systems, i.e., where little or no make up water is used. The crystals are used in washing water installations, i.e., where continual fresh make up water is introduced to the system, and the make up water is directed to flow through a suitably sized crystal container. Replenishment of crystals is easily made from time to time.

Central heating

APPPLICATIONS of the liquid "Aqua-clear" are increasingly being used in central heating systems employing a great deal of M.S. tube and ferrous equipment. In such cases the corrosion inhibiting value of the treatment is used to good advantage. Other examples would be in re-

SPECIAL SURVEY

from previous page

circulated water cooling systems to engines or plant motors.

In extensive domestic hot water systems (wasting systems) the crystal "Aqua-Clear" is used and in this case both its corrosion protection and scale formation preventive properties are well used.

The chemical is non-toxic and has the approval of all important water undertakings. It also has approval as being fit for use in drinking water supplies.

Kinnis & Brown will gladly provide free descriptive literature explaining the function and effectiveness of this well tried and valuable water treatment method.

Chemical Descaling becomes a somewhat expensive and sometimes messy necessity as a result of neglect

to treat water prior to use. However, chemical descaling is sometimes a very necessary service; it may be used perhaps in descaling an existing plant prior to installing water treatment equipment, or it may be used in economic clearance of choked equipment, pipelines, etc., in cases where renewal would be costly, if at all practicable.

Chemical descaling of small domestic hot water system can be undertaken by plumbers informed in the use of the chemicals involved, and in the effect of these when liberated to a "furred" up system.

Considerable effervescence and gas generations must be expected and escape routes allowed for same

Effective

INFORMED application of chemical descalents will reduce the possibly damaging effects of too rapid a treatment and will ensure that the treatment is complete and effective.

Continued opposite page

ARE YOU LOSING HEAT THROUGH POOR BOILER BRICKWORK ?

We offer a complete engineering and installation service for Plibrico Monolithic Refractories.

Call on us for full details.

Fitting advice and delivery from stock of Lancaster and Tonge Steam Traps and Separators; Trent Valves and Steam Fittings, Pipe Flanges; Mark IV B.C.U.R.A. Furnace Baffles; Cory Grit Arresters; Dribore Insulated Steel Stacks; Schumacher Filters for all liquids and air Cox steam and water mixers; Calorifiers; Bolton-Gray Superheaters and Ash Blowers.

Consultants

on

Domestic

water problems,

Softening

and

Filtration

Plants

HALPIN & HAYWARD LTD.

16/17 Lr. O'Connell St., 7 Bedford St., Belfast, 2.
Dublin, 1. Tel. 48638. Tel. 26343.

Irish Feedwater Specialists Co. Ltd.

OFFER A SERVICE TO INDUSTRY
IN WATER TREATMENT

Surveys made and proposals submitted for treatment of water used in Boiler, Cooling Plants, Laundries, etc.

- ★ Base Exchange Softeners
- ★ "Pluvite" fully automatic Lime-Soda Softeners
- ★ Batch Type Lime-Soda Plants
- ★ Sludge Separators
- ★ Chemical Dosage Apparatus

Complete Internal Chemical Conditioning

PYRALGOR FUEL ADDITIVES

16/17 Lr. O'Connell St., 7 Bedford St., Belfast, 2.
Dublin, 1. Tel. 48638/9. Tel. 26343.

SPECIAL SURVEY

from page five

from previous page

with no danger of ill effects afterwards.

In all cases, great care must be taken in chemical descaling work and users must be sure they know what they are handling, what the chemicals are expected to do, and how they do it.

In large jobs it is best left to trained men and generally such work is left to specialists like the General Descaling Company Ltd., of Worksops, Notts, who will look over a scheme, price its descaling, and send its own operatives to produce a quick, sound job.

This company does produce a most informative free booklet entitled "Chemical Descaling," and all interested are advised to write for a copy.

INCREASED VALUATION FOR CENTRAL HEATING

Mr. E. W. Piggott, Manager of the Irish Shell and BP Home Heating Department, had this to say about the issue: "The valuation commissioners increase valuation of houses for such improvements as parquet flooring, tiling of bathrooms and a score of such works. Central heating is just another one which gives rise to complaint by the house owner. They are all efforts at improvement of the home and appropriate to the modern way of living. I feel very strongly about the fact that people who are endeavouring to improve their way of life should be penalised in this way.

"Valuation should be based on the area which the house occupies. What is done inside the house should be of no concern to the valuation commissioner. It's a setback to some people but I am afraid the authorities will do nothing about it."

Mr. N. W. Robertson, Managing Director of the Alliance and Dublin Consumers Gas Company, said: "Surely when people improve their living standards they should not be penalised for doing so. The increase of valuation because of the installation of central heating is a retrograde step which is indeed to be regretted. It's a question of general economics. In 80 per cent. of new houses central heating is being installed. It is a deterrent in the case of owners of an old house who are thinking of putting in central heating. In their case the house would be liable to revaluation leading to an increased valuation."

Just how much will the increase in valuation be? General opinion is that it will work out at about 30/- for the average house or a minimum of £1 to a maximum of £3.

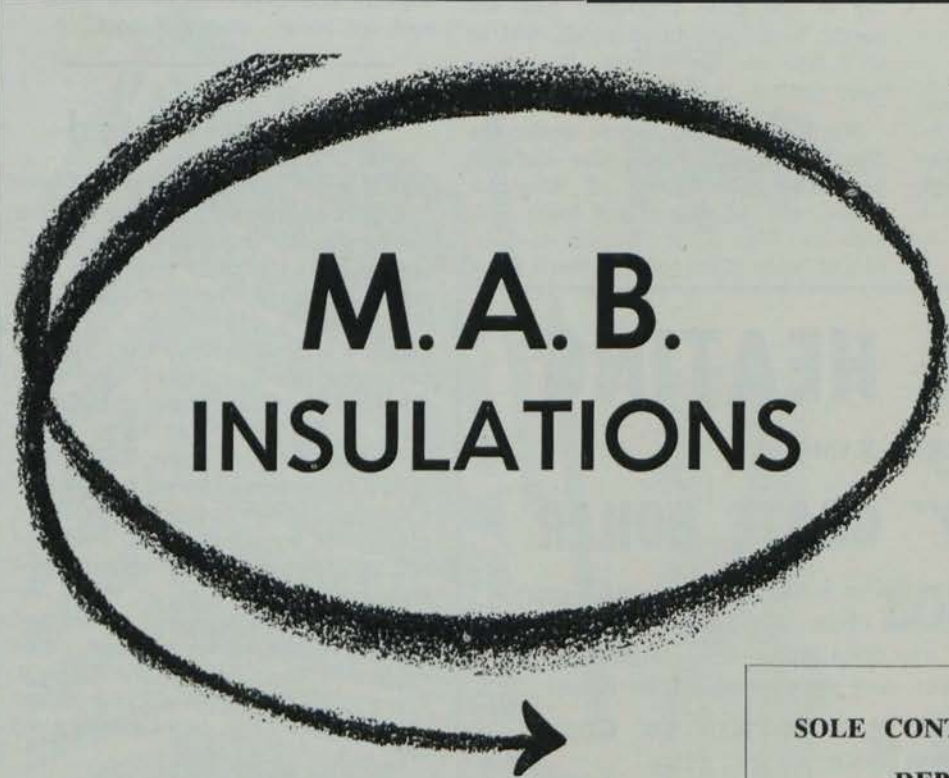

**M.A.B.
INSULATIONS**

*Specialists
In Sound
Attenuation
and Thermal
Insulation
of Ducting*

Estimates and Specifications Free on request.
**45, WATERLOO ROAD, BALLSBRIDGE,
DUBLIN. Telephone: 684017.**

**SOLE CONTRACTORS IN IRISH
REPUBLIC FOR—
THE FAMCLAD SYSTEM**

The Irish Plumber and Heating Contractor.

NORTHERN NOTES

Clean air control in North is inadequate—Minister

MR. W. J. MORGAN, M.P., Northern Ireland Minister for Health and Local Government, stated in the Northern Ireland Parliament recently that the Government had come to the conclusion that existing clean air legislation was inadequate and that nothing less than a measure with the scope and aims of the Great Britain Act would suffice, involving inter alia progressively more stringent control of smoke, grit, dust and fumes and providing machinery for the virtual elimination of domestic smoke.

He explained that present legislation governing smoke abatement gave sanitary authorities only limited control over industrial smoke and did not deal at all with domestic smoke. Domestic sources were generally reckoned to account for at least 50% of pollution from smoke.

LONG TERM

If the House in due course approved a Clean Air measure, overnight transformation of the situation must not be expected. This, said the Minister, was a long term project aimed at a steady reduction of the nuisance in the areas worst affected.

On the domestic side, progress would depend on the solution of the problem of a suitable fuel, to which it was not yet possible to see a complete answer. The availability of more abundant local supplies of coke at appropriate price and quality could be an important element in implementing the domestic programme. Substantial progress had already been made in the industrial field.

Sales change

CARRON Company of Falkirk (Scotland), continuing their sales re-organisation programme, announce that their Foundries Group, comprising in the main rainwater and soil goods, baths, and fitted goods, will be split into two areas of Divisional sales control.

Northern Ireland comes under the Northern area, which also includes Scotland and North of England. These will be controlled from Falkirk by Mr. S. R. Rogers as Divisional Sales Manager, Northern Area.

in brief...

Appointed agents

MESSRS. Peter Macfarlane & Son Ltd., engineers' agents and distributors, 23/27 Cupar Street, Belfast 13, have been appointed as official agents for Northern Ireland of Waterloo Grille Co. (Great Britain) Ltd.

Building work at the Macfarlane offices is now completed, with the entrance opening direct on to Cupar St. This entrance is also used for access to the O.B.C. despatch counter, and small parts store. Off street parking is provided in the yard for customers' loading and collecting heavy articles such as boilers and radiators.

Tender invited

NEWTOWNABBEY Urban District Council—Tenders are invited for the supply and installation of the following in connection with the proposed Sewerage Pumping Station at Whiteabbey: (1) Sewage Pumping Plant (viz., two electrically driven horizontal, direct coupled centrifugal pumps. (2) Flow Measuring Equipment. Tender documents may be obtained at the Town Hall, Shore Road, Newtownabbey, on payment of a deposit of £3 (which will be returned provided a bona-fide tender is lodged and not subsequently withdrawn), and each completed tender, in sealed envelope endorsed with the name and address of the tenderer, must reach A. R. Martin, Clerk of the Council, Town Hall, Shore Road, Newtownabbey, by 12 noon on Monday, April 29, 1963.

CENTRAL HEATING

WITH THE FAMOUS

"ALL-AROUND" GRATE BOILER

The Willis "All-Around" grate boiler is the most powerful grate boiler on the market—proof of this claim is to examine the design—the boiler fits "All-Around" any open fire, giving a larger heating surface than any 'Back' boiler—ask your merchant, he knows.

HEATS 3-4 RADIATORS PLUS PLENTY OF HOT WATER — FROM ONE OPEN FIRE

Made in Belfast by WILLIS, the Name Famous for 40 years in Open Fire Heating.

Write now for details to: Wm. Willis & Co. Ltd., 23/9 Dublin
Belfast, 2.

Items for inclusion in Northern Notes should reach us by the fifteenth of the month for publication in the following month's issue.

maintenance requirements are reduced to a minimum.

The present range covers capacities from 5 to 200 g.p.m. and heads up to 60 feet depending upon capacity. Motors supplied are from ½ to 5 B.H.P. single and three phase. These pumps are available as compact "Monobloc" units or in driving head construction for separate motor or V-belt drive. Sleeve bearings are used throughout to ensure quietness in operation.

Irish office: 20 Herbert Place, Dublin.

★ ★ ★

INTERNATIONAL BOILERS and Radiators Ltd. advise that their new Silentflo, Multiflo, and ThermoFlo domestic control heating accelerators will become generally available in June-July next. Technical production difficulties have delayed the launch date until then.

The Silentflo is a fixed head accelerator which runs in any position. The Multiflo unit combines all the

SPECIAL SURVEY

from page fourteen

advantages of the new Silentflo with an infinitely variable quantity characteristic. The Multiflo adjusts the quantity of water circulating.

Completing the new International trio is the ThermoFlo, with variable head and mixing valve, which delivers the exact amount of water needed from full boiler temperature to 50 degrees F. below.

Until the new range becomes generally available full production is continuing with the well-tried Sigmund ThermoPak and Silentflo pumps. Irish agents are Monsell, Mitchell & Co. Limited.

★ ★ ★

THE LOEWE FLYGT arrangement consists of two vertical volute centrifugal pumps mounted on a common cast iron base which incorporates the diffuser inlets and outlets for both pumps. Either pump can be switched

into operation as required and an automatic valve fitted to the discharge inlet closes off the pump casing not in use. If it is required to use both pumps together the valves take up a central position allowing full flow and pressure to the discharge line.

The pump and motor on either side can be dismantled for repair, overhaul or replacement without interfering in any way with the operation of the remaining unit. All the advantages therefore of the older type arrangement with two separate pumps in parallel are maintained with the added reduction in capital outlay and considerable saving in space.

There has also been introduced during the past year the "Silenta" hot water accelerator. The Silenta has already established itself as a robust and reliable unit in service. H. R. Holfeld Ltd., 2/4 Merville Road, Stillorgan, Dublin, also announce that they will display on Stand No. 377 at the R.D.S. Spring Show a selection of piston, centrifugal, volute centrifugal, contractors', sewer-

Continued overleaf

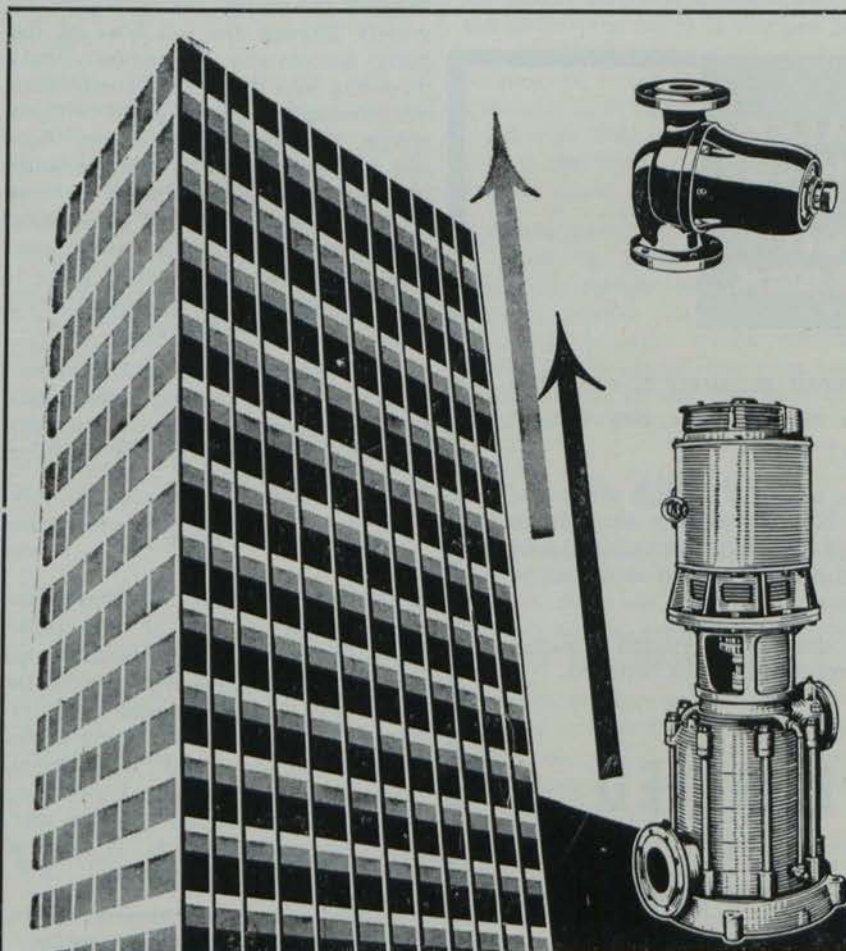

**SILENTA
HOT WATER
ACCELERATORS**

•
**LOEWE FLYGT
TWIN PUMP
CIRCULATORS**

•
BOOSTER PUMPS

•
**H. R. HOLFELD. Ltd.
STILLORGAN**

Phone 881603 (5 lines).

The Irish Plumber and Heating Contractor.

age, boiler feed and submersible pumps and a large variety of coloured and black and white photographs illustrating these units in service.

★ ★ ★

WATER SYSTEM air problems can be cured by using the Penn Air Volume control kit. Penn's WC-98 air volume control kit consists of a Type 195 air charger and Type 191 tank unloader.

The "195" provides positive air charging at relatively high rates directly to the storage tank **without** passing through the pump. Flow requirement for air charging is from 5 to 30 gallons a minute at 20 psig. cut-in pressure. Then, the "191" bleeds off excess air and maintains proper air volume.

Used on any type of system—deep, shallow or flowing wells—air problems will be eliminated, say the manufacturers.

Irish agents: Manotherm Ltd., Corn Exchange Buildings, Dublin 2.

SPECIAL SURVEY

from previous page

★ ★ ★

IN THE PAST 12 months Holden & Brooke Ltd. have introduced three new products covered by this Review. They are a glandless accelerator, storage calorifiers and non-storage calorifiers.

The Selflo Heating Accelerator is completely silent, and by incorporating a wet rotor maintenance has been virtually eliminated. Four sizes are available, with maximum head and flow limits of 15 ft. and 64 g.p.m., respectively. The wet rotor design has made it possible to offer a unit which is not only functional, but which also presents a pleasing appearance.

A range of storage calorifiers manufactured in accordance with B.S.S. 853, designated Wython, was intro-

duced at the beginning of the year. Storage capacities of up to 600 gallons can be offered with transfer duties up to 2 Mill B.t.u.'s/hr. Calorifiers with shells in either copper or mild steel are available.

The Braddon range of non-storage calorifiers is also manufactured to BSS.853, but whereas the Wython works on a steam to water principle, these calorifiers use water as the heating medium. The maximum transfer duty is 10 Mill B.t.u.'s/hr. and 16 sizes are available.

Irish agents: G. C. Pillinger & Co. (Ireland) Ltd., 20, Sycamore St., Dublin 2, and 35 South Terrace, Cork; J. Hind & Sons, Ltd., Lowan Engineering Works, Prince Regent Road, Castlereagh, Belfast.

★ ★ ★

THE NEW Criton NC range of heating pumps has been evolved from the well-known Criton accelerators. The new Criton pump provides full bore gravity flow—(when the pump is stopped the water can circulate by gravity through the full bore of the pump without any obstruction); direct mounting into the heating main; easy maintenance of pump gland without system drainage; variation of flow rate by changing pulley sizes; ease of installation, the main pipe of the unit forming a continuation of the heating main; sleeve bearings for silent running and simple maintenance, and adjustable studs providing a tensioning device for the vee-belt drive.

A special feature of the Criton NC design is that motor and drive alteration can be carried out without any disturbance of pipework or draining of the heating system.

★ ★ ★

STUART-TURNER LTD. have introduced a range of new cellar pumps. The Stuart float switch stops and starts the cellar-pump as the water levels falls or rises—quite automatically. It is designed to stand up to damp conditions and requires no maintenance. The actual switching on and off is through a sealed mercury tube. The switch is supplied complete and ready to instal.

Irish agents: D. P. Engert & Co., 5 Ardee Road, Rathmines, Dublin.



Pour OXYPIC, the **guaranteed** leak repair preparation, into a hot water installation and seal leaks, no matter where they are, in **30 minutes!**

Faulty fittings, bad threads, sand holes, any leak through any cause is sealed economically and quickly. No dismantling needed; no patches or welding; no need to even **find** the leak; no trouble at all! *Oxyptic prevents rust and scale. It can also be used as an active leak preventive.

N.B.—Unsuitable for domestic or draw off systems. Retail Price £1 per tin C.O.D., money refunded if not satisfied.

Full details from:

H. PICKUP LIMITED

(SOLE MANUFACTURERS)

DEPT. IP.3, ROSCOE WORKS, SCARBOROUGH, YORKS.

the
author

John G. Bolton

Lecturer in Plumbing and Heating at the College of Technology, Bolton Street, Dublin.

CORROSION IN METAL TUBES AND FITTINGS

WHEN the vast wrought-iron roof of Cannon Street Station, London, was erected almost 100 years ago, it required 2,200 tons of iron-work. When, however, it was decided to dismantle it some five years ago, it weighed only 1,825 tons! Some 375 tons of iron had vanished, notwithstanding regular painting and maintenance.

Again, in America, the cost of corrosion to the nation has been put at more than £6,000 million!—a fantastic figure, especially when one thinks of the millions of gallons of paint used in an effort to prevent it!

Facts like these give one food for thought, and we, in the plumbing and heating industry do not, perhaps, give sufficient attention to the problems of corrosion which we meet in our everyday work.

This slow, continuous eating away of a metal is, of course, nature's own way of trying to re-convert or transform the metal back to its original state.

The agencies which cause this corrosion are many, and their results are to be seen under such forms as erosion, tuberculation, deposit attack, galvanic action, chemical and electrochemical attack, graphitisation, dezincification, etc.

Protection

WE are all familiar with the sight of rust-covered iron, green sulphate or patina on copper, and lead with traces of white lead formation, especially when removed from old

gutters with oak sole boards, but we must not, of course, condemn all forms of corrosion as bad. Indeed, it may, in some cases act as a form of protection!

For instance, in copper roofing, once the green patina forms on the surface, all further corrosive action ceases and the underlying metal is shielded from attack. If, however, the patina is scraped or brushed off, the attack continues until the metal is destroyed.

Likewise lead, once the oxide skin forms, the metal is sealed off from further action.

In the past, the study of corrosion in plumbing metals was, in general, neglected, perhaps because the metals then in general use were basic or elemental, in other words, not much different in structure from their native form, so that serious corrosion problems did not exist.

In waters

TODAY, we face a different situation, due to the combinations and multiplicity of metals and alloys used in the trade, and the increasing use of waters treated with chlorine, flourides and other chemicals.

A typical everyday example of this increase in corrosion is the dezincification of hot pressed brass fittings—the 'meringue' type of dezincification in which the corrosive products are deposited in a bulky insoluble form on the surface of the brass so eventually producing a blockage. This action on the brass has been shown

Continued page thirty-five

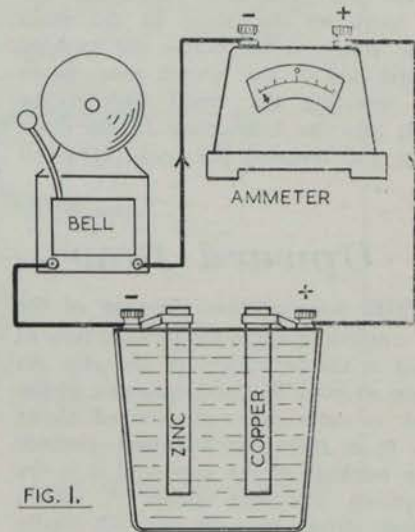

A SIMPLE VOLTAIC CELL

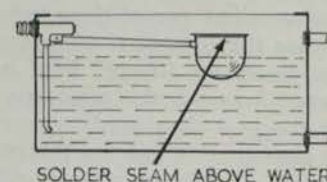
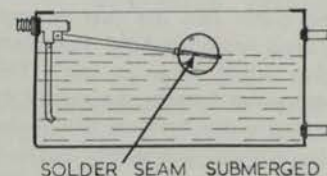

FIG. 2

times called a "scallop". It resembles a gimlet used for boring holes, in wood except that its end flares out to form a wide cutting edge and it is worked by hand. The leading "gimlet" screw enters the wall of the lead pipe followed by the flared part of the tool, which scoops out a hole large enough for the next operation. If a pipe opening tool is not quickly available, then a hole drilled in the pipe wall with a 5/16th" bit in an ordinary engineer's drill will serve the purpose quite well. Take care not to let the bit ride right through the pipe wall so that it cuts the inside of the pipe wall opposite.

(2) **Bent bolt.** This is a short, round steel bar about $\frac{1}{2}$ " in diameter. One end of the bent bolt is tapered down to a diameter of about $\frac{1}{4}$ ". Both ends are bent a little—hence the name "bent bolt". It is used with a hammer to work up the "cup" in the main pipe which is to receive the tapered spigot end of the branch pipe. Begin by inserting the small end of the bolt into the hole made in the main pipe and levering the lead pipe wall up.

Upward flow

THIS will increase the size of the hole and begin the upward flow of lead in the formation of the cup. As soon as possible the larger end of the bolt is used and well directed blows on to it from the hammer continue the working of the cup until it is the required size and shape. A tanpin lightly driven into the cup will finally true up any slight irregularities and ensure a good fit for the circular branch pipe entry.

(3) **Scribing Plate.** This is a metal plate with three points on its bottom edge. The outer two dig just enough into the lead main to hold the plate in position while it is in use. The centre point locates the centre of the plate with the hole in the main. Vertically up from this centre point is a series of small holes. Using the compasses, adjusted for the required size of joint, select one of these holes so that when the compasses are swung the point traces the line of joint on the blacked area of the main pipe. The shavehook is then used to shave clean all lead areas within the marked joint line. If a scribing plate is not handy, the handle of a hammer can be placed over the branch opening,

from page eight

Joints for pipework

and will receive one point of the compass.

Spigot joint

THE soldered spigot joint may be used to join "cap and lining" connections to bath or basin taps; for joining brass or copper trap unions to lead waste pipes, or for joining brass overflow connections to lead warning pipes.

The joint is easily prepared and needs a special tool kit which will suit $\frac{1}{2}$ " to $1\frac{1}{4}$ " lead pipes and costs about £3. Tinman's solder, Grade A to B.S. 219, is used. About an inch length of this solder will be enough to make a good joint.

It is the fact that this joint needs so little solder that makes it so economical; about 40 one inch joints can be made with 1 lb. of tinman's solder, whereas 1 inch wiped soldered joint requires 1 lb. of plumber's solder.

The preparation of this joint and the tools used in the process are shown in illustration.

Unites the two

IT is important that the whole space between the brass or copper liner and the inside of the prepared lead pipe should be filled with solder which "tins" and unites the two. A ring of solder will appear at the top of the joint when it is correctly made, but one must be careful, for sometimes the solder ring will appear before the air has escaped from the space below. This will prevent the solder from completely filling the space and the result will be a poor joint. The blowlamp should be kept moving up and down the joint area to keep the solder molten and to expand the air, forcing it out so that the solder can run down and take its place.

Copper tubes

COPPER tubes may be jointed by compression fittings or by solder capillary fittings.

Compression fittings fall into two distinct groups—Type A and Type B.

1. **Type A** fittings are known as non-manipulating fittings and require only that the tube end should be cut square and to length. Fig. 36. They require only a soft copper ring or other device which is compressed, between the inside of the fitting and the outside wall of the tube, and there is little or no deformation of the tube wall.

2. **Type B** fittings are known as manipulative fittings. They are designed in such a way that during the making of the joint the tube end is shaped or worked so that in the final operation it is "squeezed" and securely held between the various components of the fitting. (See illustration here). This manipulation of the tube end ensures that the fitting cannot pull off the tube, and for this reason most water authorities insist upon Type B fittings being used for copper water services which are to be buried underground.

Soft tube

COPPER services underground are generally in B.S. 1386 tube because this soft tube is made in longer lengths, needs fewer joints, and is therefore economical. It is clear that the relatively soft tube would "give" to Type A compression fittings, but equally, since it is soft and easy to work, it is very suitable for the Type B joint which guarantees a sound joint—an important matter for pipework laid under the ground where an undetected leak could cause a considerable loss of water.

Gunmetal is an alloy of copper and tin. You will remember in a previous chapter that it has a very high copper content—much greater than that of brass, of which these fittings are normally made for work above ground. Gunmetal is more resistant to corrosion than brass, and for this reason fittings of gunmetal might well be used for copper services underground where the soil is known to have corrosive tendencies.

Underground copper tubes to B.S. 1386 may be jointed by solder capillary fittings where the local Water Undertaking permits.

Solder Capillary fittings are made of good quality brass, or of copper. The choice of material depends upon the importance of appearance or cost,

from previous page

Joint for pipework

and whether the fitting is for use underground or above ground (illustrated).

Current

YOU are perhaps aware that two dissimilar metals in contact in a substance which can conduct an electric current, will work like the two plates of a Voltaic electric cell, producing very small amounts of electric current. The flow is created at the expense of one of the plates, which is electro-chemically corroded away. (See illustrations).

Unlikely

A MOIST, acid soil could form such an electrolyte or conductor of electricity; and the copper tube with brass fittings could provide the dissimilar metals. Hence, while brass fittings are quite satisfactory for all work above ground, and for underground work where the soil is known not to be electrolytically corrosive; where there is evidence of acidic tendencies it is best to use copper fittings in order not to introduce a second metal.

Solder capillary fittings admittedly introduce tin-lead solder alloy, which is a dissimilar metal, but this alloy has so nearly the same electro-chemical properties as the copper tube that serious electrolytic action between the two is very unlikely.

Solder capillary fittings (illustration 38) may have a ring of solder already inserted in their sockets, in which case the copper tube end is cleaned with fine steel wool, fluxed, and inserted into the socket of the fitting until it hits the tube stop in the fitting. Heat is then applied, usually from a blow-lamp, until the solder melts and flows by capillary attraction all around the closely fitting outer wall of the tube and the inner wall of the fitting. This is just one example of the way in which capillary may be useful to the plumber.

From outside

SOME of these fittings will have no solder ring insert, and solder will have to be fed from outside to make the joint. Most of these solderless capillary fittings are "pre-tipped" in-

side. They need to be carefully examined and some will perhaps have to be cleaned before the joint is assembled for soldering.

Fine sandpaper wrapped round a pencil provides an easy way of cleaning inside a fitting, but do not overdo this or you may so increase the capillary gap between tube and fitting that it will not work as it should. In most cases, one or two brisk twists with the sandpaper or fine wire wool will be sufficient. In some cases "active" fluxes are used, and mechanical cleaning is reduced to a minimum; but do take care to wash off all surplus flux after the joint is made or it will continue to act on the tube face, leaving unsightly corrosion marks.

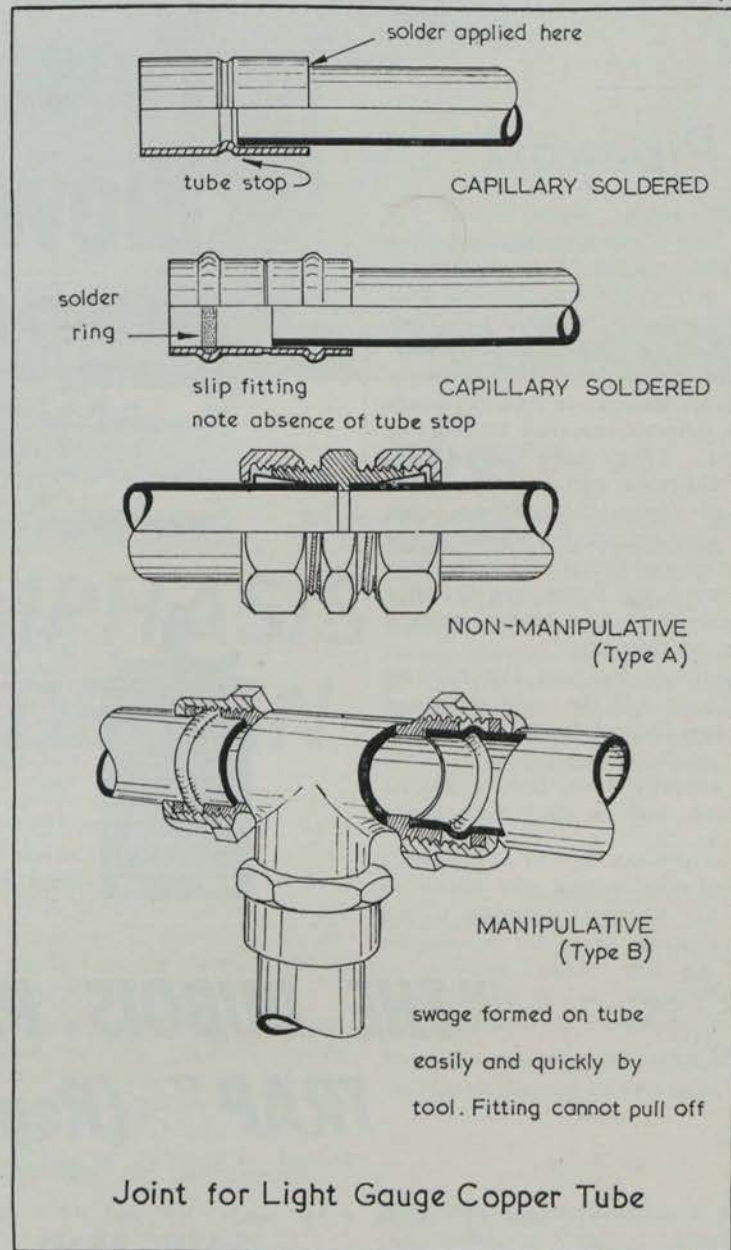

Joint for Light Gauge Copper Tube

Equal gap

CAPILLARY action draws the solder into the joint, and it is necessary that there should be a fine and equal gap all round between the tube and the fitting. Soft B.S. 1386 tube might accidentally lose its true cylindrical bore and this could prevent, or make difficult, its entry into the socket of the fitting. A special steel tool, resembling an inside and outside drift, is obtainable to restore the inside and outside cylindrical shape of copper tube to be used underground, and this should be employed where the tube is to be jointed by solder capillary fittings.

Continued overleaf

The Irish Plumber and Heating Contractor.

from previous page

Pipework

Bronze welded joints, which are made with oxy-acetylene welding equipment, special bronze welding fluxes, and copper-zinc alloy filler rods, are generally accepted by Water Undertakings for use in copper water services.

Weldable fittings are specially made for this purpose and may be brass or gunmetal. They have sockets to receive the tube end just like other forms of copper tube fittings, but there is also an annular groove at the top end of the socket which forms a gap between the fitting and the tube wall into which the bronze welding rod can be introduced.

Alternatively the tube end may be "belled" out and the weld deposited in the cup formed in this way. This method is cheaper and quite satisfactory if expertly done. Bronze welded pipe joints will be dealt with more fully later on.

To be continued

Kosangas Blow-Torches

for every plumbing job!

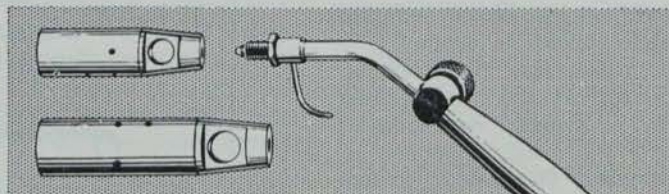

There's a wide range of Kosangas blow-torches, for all types of plumbing work. They're far more efficient than the conventional types.

The Kosangas TH3 and TH4 high pressure blow-torches are specially designed for *paint-burning, pre-heating and soldering*.

The Bullfinch Mark II has a full range of heads, including soldering attachment. Use Kosangas blow-torches, with the small Kosangas portable cylinder, also for *roof-felting, jointing of plastic pipes, and other heating needs*.

A plumber's portable furnace with wind protected burner is available.

Send for details to: McMullans Kosangas Ltd., 1 Upper O'Connell St., Dublin. Tel: Dublin 40761-4.

A NEW
PRODUCT

"THE DUBOIS PLASTIC TRAP" (Regd.)

A NEW
PRODUCT

Provn. Pat. No. 38070/60.

1½" and 1¼" diam. x 1½" seal "S" and "P" BLACK HIGH DENSITY PLASTIC TRAPS

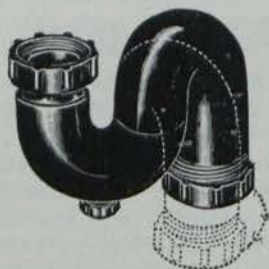

Orthodox Shape!
Smooth Bore Tubular construction.
Outlets can be turned through 220°.
A two-piece trap at a one-piece price.
Outlet on 'S' trap turned to inlet forms a through-bore bottle trap.
Frost and damage resisting.
Light weight = lower transportation costs.



Manufactured by:—

THE DU BOIS COMPANY LIMITED
15 Britannia Street, London, W.C.1

Telephone No.: TERminus 6624-5.

Telegraphic Address: "Bleitrap, London."



INDUSTRIAL, COMMERCIAL AND HOSPITAL SANITARYWARE—CONT.

CURRENT EMPHASIS ON GOOD DESIGN

WASH basins for hospital use are produced in wide variety and are freely adapted for ward or theatre use. In the latter case, there is ample choice of fixtures without tap-holes to be used in conjunction with wall-mounted fittings. Generally these are equipped with standing wastes but without overflow.

There is, too, an equally wide range of w.c.'s, many of which are of the corbel type—some with supporting chair concealed in wall and floor—leaving the floor space clear for cleaning. Most makers have w.c.'s of varying heights from 12" to 16". Many of the w.c.'s mentioned earlier in this article are just as suitable for hospital use as they are in industry, each embodying every facility for easy cleaning under arduous conditions.

Dual-purpose

Some items have a dual-purpose facility, like the baby's bath which, because of its flat underside and its controls mounted on the front face, could readily serve as a washbasin for wheel-chair patients. Another dual-purpose item is a new bath of small dimensions in which the patient sits across the bath with feet on the floor. Intended as a "special treatment" bath, because of its shallow depth, it

serves quite well also as a hip bath which can be used easily by aged, infirm or physically disabled people. For that reason alone, this bath is likely to be much in demand in geriatric wards, or in maternity or surgical wards for the application of special immersion treatment.

It could serve a most useful purpose, too, in old people's homes, where the residents, because of their age, are often afraid to risk full immersion in a normal bath because of the difficulty of entering or leaving one.

Special-purpose

Special-purpose equipment, such as bed-pan washers, macintosh slabs and slophoppers, are made in a variety wide enough to meet every requirement. Here, too, there is constant improvement—mostly in detail. If such an item can be improved either in design or function, that improvement is made.

In thinking of the more obvious items of sanitaryware for hospital or industrial use, the provision of cleaning and kitchen equipment is apt to be overlooked. In every works wash-room, for instance, there should be sinks—and possibly a slop-hopper—for the cleaners to use; sinks which

above...

LEFT—The new "Glacier" industrial washing trough in ceramic glazed fire-clay is shown here in 'island' installation. The spacings arising from the indentations of the front faces are clearly shown. Reduced pipework together with the enormous strength of Fireclay and the lasting impermeability of vitreously fired glaze virtually eliminate maintenance costs.

★ ★ ★

CENTRE—A new special-treatment bath in which the patient sits across the bath. Although designed for medical purposes, it can serve equally efficiently in geriatric wards and old people's homes where age or infirmity rendered normal bathing a difficult process.

The attachment of a grab-bar greatly facilitates the use of the bath in such cases.

★ ★ ★

RIGHT—Complete isolation of the mixing chamber is a special feature of this new babies' bath from the Niddrie fire-clay works of Messrs. Steele Brothers & Sons Ltd., at Portobello, Edinburgh, 15. So, too, is the ample dimension of the soap sinking—more than 46 sq. ins.—in the back ledge.

are strong enough to withstand contact with metal pails and mop-buckets. Indeed, there should be such provision in every washroom and toilet for public or employees use.

Continued overleaf

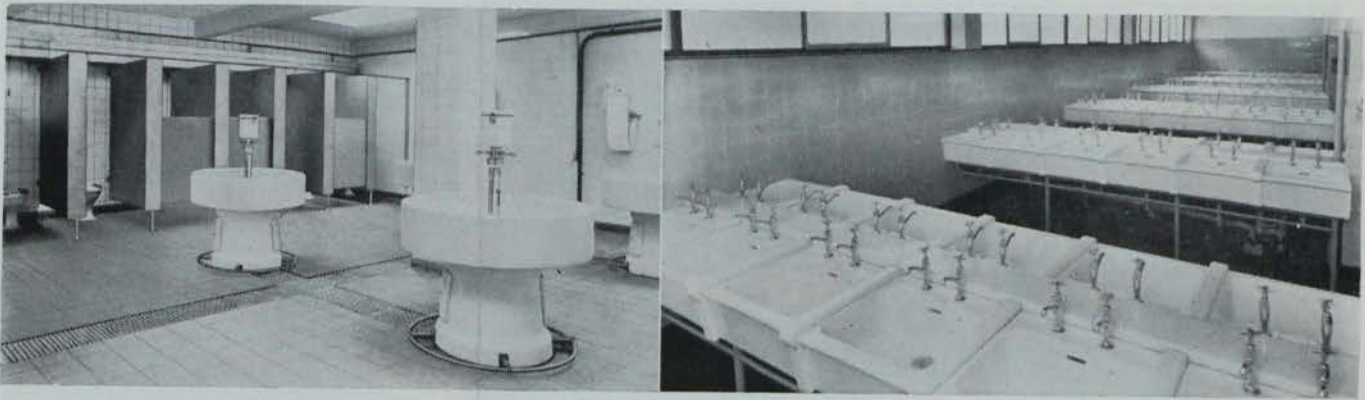

from previous page

Plastics have their part to play

Finally, a word about plastics. Undoubtedly, plastics have a part to play in plumbing and sanitation. The plumber must remember, however, that the word "plastics" covers

Above . . .

LEFT—These w.c.'s and circular ablution fountains ensure hygienic efficiency and permanent resistance to heavy and continuous use in this modern installation. RIGHT—Ceramic glazed fireclay back-to-back ablutions tubs at a power station afford ample 'peak-period' capacity.

many different substances. Perspex is one, resin-bonded glass fibre is another, with polypropylene adding to the range used for making certain types of sanitaryware. Each has its

own special qualities, and obviously, therefore, the wise plumber will take the trouble to gain all the knowledge he can about these different materials.

NEW REDUCING VALVES RANGE

A NEW range of general purpose reducing valves has been introduced by Sir W. H. Bailey & Co. Ltd. (Albion Works, Patricroft, Manchester), for use mainly with steam, water and air lines.

Known as the Class "H" range, the new valves supersede the present Class "A" range, and are available in six sizes from $\frac{1}{2}$ inch to 2 inches with B.S.P. end connections. The design allows a maximum inlet pressure of 250 p.s.i. and a minimum reduced pressure of 5 p.s.i.

ABOUT THERMOSTATIC MIXING VALVES

WITH REFERENCE to certain comments in the February issue concerning bi-metal strip normally found in thermostatic mixing valves, Modern Plant, Ltd., Crumlin Road, Dublin, write stating that from personal experience they had found that in colour

TRADE

TOPICS

development of films that they can hold hot and cold water to a blended temperature of $68\frac{1}{2}^{\circ}$.

Again, on the very delicate kidney operation they can hold the same degree of accuracy to within 64° . In the salic-blanket operation on the heart they can again hold to within plus or minus $\frac{1}{2}^{\circ}$.

The comments in the February issue report with regard to "furring-up," they said, gave one a completely wrong impression.

Any type of water fitting would furr-up under certain conditions. It was not common to bi-metal strips. This furring-up, the firm adds, has in their experience rarely had any bearing upon the accuracy of temperature control since the furring-up generally occurs on the outside of the coil and does not affect its contraction or expansion.

ATTENTION!

THE JUNE 1963 Register of Manufacturers, Agents, Representatives and Distributors of Plumbing, Heating, Air Conditioning, Ventilation and Insulation materials and equipment available in the Republic of Ireland and Northern Ireland is now being prepared. The Directory this year will be greatly enlarged to accommodate the considerable number of additional entries which have been submitted for inclusion.

★ ★ ★

IF YOU come under the heading of any of the categories listed in this and other issues you are invited to submit details without delay.

Please Note Closing Date — Saturday, 4th May.

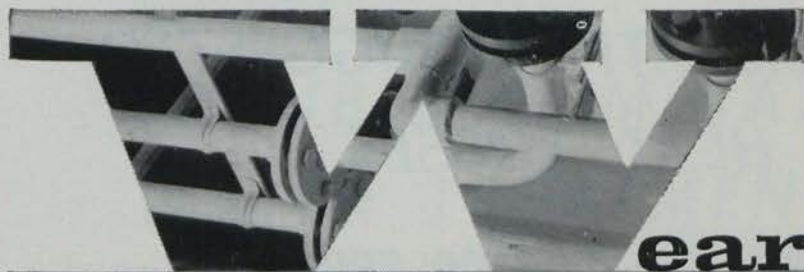

ear and wavin

wavin

PIPES LIMITED
Balbriggan, Co., Dublin.
Telephone: Balbriggan 160,

Defeat the corrosive menace of chemicals and acids! No loss of production or dangerous bursts. Wavin P.V.C. pipes wear wonderfully because they do not wear at all. Wavin pipes are non corrosive, immune to all chemical attacks, light, inexpensive and easy to install. Where there's wear use Wavin. That's sense.

Thermal Insulation

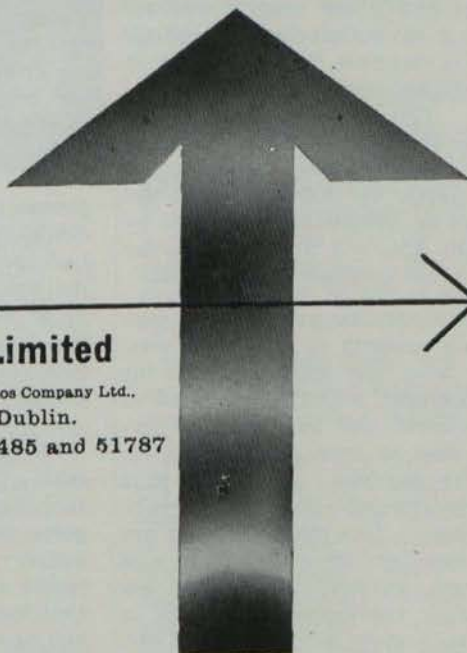

M. A. Boylan Limited

A subsidiary of The Cape Asbestos Company Ltd.,
50a Harcourt Street, Dublin.
Telephone: 52397, 54485 and 51787



We are the foremost insulation specialists in the country with many important insulation contracts to our credit. The huge Oil Refinery at Whitegate and the Derrinlough Briquette factory are recent examples. If you have any heat-loss problem, discuss it with our highly experienced technical staff. Our recommendations are offered free and without obligation.

Sole agents and stockists for:

- 'Rocksil' rock wool
- Rigid Sections
- Flexible Sections
- Blankets
- Mattresses (wire-mesh-backed)
- Loose Wool
- 'Caposite' amosite asbestos moulded blocks and pipe sections
- Also full range of plastic materials and hard-setting compositions.

The Irish Plumber and Heating Contractor.

COMPULSORY LEGISLATION SUGGESTED TO BEAT HEAT LOSSES

MR. DERRY McCaffrey, M.A., M.A.I., A.M.I.C.E., A.M.I.C.E.I., managing director, W. H. Heywood & Co. (Ireland) Ltd., who read a paper to the members by the Dublin Rotary Club at their luncheon meeting in the Royal Hibernian Hotel in March, said that an appalling amount of fuel was wasted every year by firms because of heat losses through their factory roofs.

In Britain, he said, this assumed such serious proportions that an Act was passed in 1958 which compelled owners of all industrial buildings to conform to certain standards of insulation. He would like to suggest that legislation on the same lines would be beneficial to this country, too.

Besides decreasing the fuel bills of individual concerns, it would benefit the country's overall economy by lowering the amount spent in the industrial sector on fuel to produce wasted heat.

Welcomed

"The building industry welcomes Mr. Domough O'Malley's announcement recently of the proposed National Building Council whose recommendations we hope will ensure a planned steady expansion of the volume of work. I would suggest, too, that legislation regarding the standard of insulation in factories would be a factor which would allow a definite planned amount of work to be provided for in this sector for many years to come," he said.

"Political considerations apart, the help that Mr. O'Malley is giving to the building industry, which is second only to agriculture in importance, shows the wisdom of the Government's appointment of a young man to this post, a man who, being also a professional engineer, is fully alive to the problems of the industry."

Depending on the amount of insulation required and on the type of premises, different insulation board would be used such as fibreboard, plasterboard, aeroboard, fibreglass, etc. Those boards were generally two feet wide and carried an alumin-



MR. DERRY McCaffrey

**"An appalling
amount of fuel
is wasted
every year"**

ium tee section suspended from the steel roof trusses.

"The importance of insulation in a factory will be brought home to you when I say that in a recent small installation, entailing a capital cost of £900, there was a fuel saving of £548 annually thereafter."

"You might ask, what are our main problems. We have the normal ones of making sales, keeping costs down in order to be competitive, but the two primary ones are: (1) organising jobs when they have such a varying material and labour content and are so spread out geographically, and (2) obtaining payment for work done in a reasonable period after its completion. This is due to the system whereby the subcontractor, being responsible to the main contractor, is paid directly by him. He will not pay until he himself has been paid by the client who will not pay until the architect has certified the payment.

"This means the subcontractor presents his account to the main contractor, who may include it with his own statement, which is presented to the architect and his quantity surveyor, who in turn passes it to the client for payment. The client pays the contractor, who then pays the subcontractor. This means that we are three steps away from the person who pays and, as you can imagine, we have often considerable difficulty in obtaining prompt payment," said Mr. McCaffrey.

When asked how he came to be in

his present job. Mr. McCaffrey said that he is a civil engineer by profession but became more interested in the practical and business side than the academic. Soon after qualifying he decided to obtain as wide and as varied a practical experience as possible by travelling and working abroad before finally settling down in his home country.

Returned

"I went abroad to the South Pacific, Australia and New Zealand first for three years and returned here for two, then off to the Middle East for two years, then to the United States for a year; back to Ireland again; a period in England and back here at last. I would recommend the same course to anyone starting out and I don't think I would change it if I had to do it again. Though I miss the sun and the heat, I am delighted to be back and to be taking part in the development of my own country with the help of knowledge I have gained in my travels," he said.

Mr. D. McGreevy, managing director of the Building Centre, Dublin, said that at long last something was going to be done about the building industry, and he imagined that this would not only help to stop emigration, but that skilled craftsmen who had been forced to leave home would be able to return to a more secure future in Ireland.

CORROSION—from page twenty-seven

TROUBLE ELIMINATED BY SMALL WATER TREATMENT VARIATIONS

by the British Non-Ferrous Metals Research Association to depend on the composition of the water supply to the fittings, being prevalent with some waters and entirely absent with others. As a result of research it has been

found that this trouble can be eliminated by small variations in water treatment.

Again, we all have experience of the increase in recent years of ballvalve failure, perhaps, after it has only been a short period in use. This is due, in many cases, to a type of dezincification by the selective solution of the zinc from the brass so leaving a spongy copper remainder through which leakage can penetrate.

ordinary tap water (not distilled water) an elective current will flow if the circuit is completed by a short piece of wire from the zinc to the copper. This results in the positive copper plate, which is called the **cathode**, attracting electrons from the negative zinc plate which is called the **anode**, but in giving up the electrons, the zinc gradually becomes eaten away or disintegrates into zinc sulphate, the copper plate being, of course, unaffected.

This was the basis on which the first electric cell was constructed by an Italian scientist, Alessandro Volta (1745-1827).

Electric current

YOU may say "how does all this enter into plumbing and heating installations?" Well, after the original discovery, it was soon proved that any two metals in close contact and surrounded by a conducting liquid will produce an electric current. This current, of course, will vary in potential (voltage) depending on the metals and the conducting solution. In the example of the copper and zinc plates, the difference in potential is about 1.1 volts regardless of the size of the plates. However, the larger the plates, the greater the amount of current (amps) that will flow. In this respect it is interesting to note that the weight of metal transformed into ions, or, in other words, the amount of corrosion which will take place under such conditions, will depend on the quantity of electricity generated, and the time it is flowing for. It has been calculated that a current of 1 ampere flowing for one year can corrode about 20 lbs. of iron, or about 70 lbs. of lead.

Earlier, it was pointed out that, in electrolysis, one metal was corroded, while the other was relatively unaffected so that the next point of interest to us is to note the reaction of metals to each other. What metals

Continued overleaf

WELDING TECHNIQUES



In no other branch of Engineering do so many individual problems arise as they do in Welding. We are equipped to give you a first-class Service on all your Welding problems. We supply and service the best equipment in this ever-widening field. We offer you the most up-to-date plant from the leading manufacturers in many countries.

WELDING SERVICES LTD.

14-16 Amiens St., Dublin. Ph. 47051-2-3

Charcoal

WHERE iron is concerned, we have, of course, always been faced with corrosion problems of one sort or other, but there seems no doubt that iron produced in the last century was more corrosion resistant than many of our present day products. An explanation of this may lie in the fact that the charcoal used for the reduction of the metal contained less sulphur, and that the atmosphere in those days was almost completely free of deleterious compounds of a corrosive nature which have a great influence upon the life of a metal, particularly in early life.

Electrolytic Corrosion

PERHAPS one of the most common causes of corrosion among metals in general use by the plumbing and heating engineer, is that caused by electrolysis, also spoken of as galvanic action, electro chemical action, etc.

To understand how this type of corrosion is set up a knowledge of the simple voltaic cell is helpful (Fig. 1).

Here we have two plates of metal, say copper and zinc. These, if placed together when dry will have no visible re-action (although scientists tell us that some slight interchange of electrons may occur) but if the copper and zinc are placed in a solution of dilute sulphuric acid, or alternately a simple salt water solution, or even

The Irish Plumber and Heating Contractor.

are likely to corrode each other, and what is the best combinations to prevent corrosion?

Scientists again have helped us out by publishing a table for the common trade metals as follows:

**ELECTROMOTIVE SERIES
OF METALS**

"BASE" END	ALUMINIUM
	ZINC
	CHROMIUM
	IRON
	NICKEL
	TIN
	LEAD
"NOBLE" END	COPPER

When any two of these metals are used in making a voltaic cell, the one higher in the table has the lower potential. The metal that is lower in the table is positive with respect to the one that is higher.

An important aspect of this electromotive series which should be noted is the fact that the further apart metals are in this table, the more severe will be the reaction if they should come in contact under suitable conditions.

Example

A GOOD illustration of this would be an aluminium valley gutter clinked to a copper gutter. Here the conducting liquid would be the rain-water, and the result, a violent eating away of the aluminium at the joint. If, however, a zinc gutter and an aluminium gutter should be clinked together under the same conditions, no significant action will take place.

Again the use of zinc or heavily galvanised nails to hold aluminium roofing is quite in order, but to use copper nails for the same purpose would cause the aluminium to corrode at each nail hole. The reverse holds good with the copper nailing of lead when no action will be noted, but

from previous page

**CORROSION OF
METAL TUBES,
FITTINGS**

try galvanised or zinc nails and the trouble at once takes place with the nails being eaten away.

We are all familiar, of course, with the steady deterioration of a copper ball or float in a store tank in consequence of the solder seam being eaten away. This again is a sure indication of electrolysis between the solder seam and the copper in the presence of moisture.

Many varieties of copper floats have been devised to overcome this—a typical design having the seam above water level (Fig. 2). Other floats have the seams brazed to prevent corrosion.

Same trouble

THE same trouble occurs with copper hot-water cylinders where the seams are riveted and soldered. A green stain and a drip is the result. The advantages of brazed copper cylinders are obvious in this case.

An axiom in copper roofwork is the necessity to prevent iron nails and screws in the sole boards or rolls, coming in contact with the copper sheet—brass screws and copper nails being essential if there is the slightest possibility of the copper coming into contact with them.

Another everyday example of electrolytic corrosion is, of course,

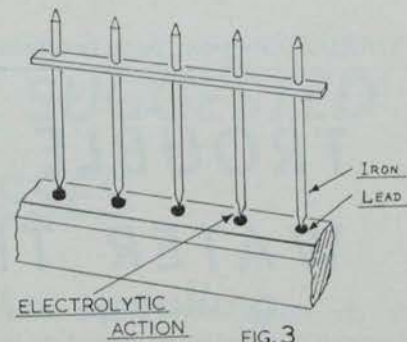

the eating away of an iron railings at the point where it is leaded into a stone base. Here, the iron, if not constantly painted, will be found to be eaten to a pin point just at the juncture with the lead (Fig. 3). The iron in this case is subject to anodic attack from the lead, rain again acting as the conducting solution. While on this point, I would mention that some authorities recommended the use of melted sulphur instead of molten lead for holding the railings.

I happened to mention this on a Building Course held in Co. Kerry some years ago and immediately some students told me that they had often seen this done by blacksmiths and others when erecting iron gates, etc. Cement can, of course, be used, but it takes time to set, during which the railings must be supported.

Many other examples of electrolysis will, no doubt, come to mind, but from those already mentioned, it can be seen that the problems of corrosion caused in this way present a very difficult situation where plumbing and heating work is involved. In our daily work we often have to "mix" metals and it is therefore important to understand the principle involved in order to prevent trouble later.

In next month's issue, other aspects of corrosion will be considered particularly with regard to the development of anodic and cathodic reaction in pipelines.



GAS OR ELECTRIC?

WELDING OF COURSE!



But we also have a wide range of cutting and heating equipment, accessories and safety equipment. Delivery services everywhere.

CONTACT INDUSTRIAL GASES (I.F.S.) LTD., DUBLIN

1963 Directory of Manufacturers, Agents, Representatives and Distributors

★ The June 1963 Register of Manufacturers, Agents, Representatives and Distributors of Plumbing, Heating, Air Conditioning, Ventilation and Insulation materials and equipment available in the Republic of Ireland and Northern Ireland is now being completed. The Directory this year will be greatly enlarged to accommodate the considerable number of additional entries which have been submitted for inclusion.

If you come under the heading of any of the categories listed in this, or the last three issues, and have not sent in details, we would ask you to do so without delay. **A limited number of copies of last year's Directory is available should you wish to make alterations or amendments.** Names and addresses of Agents and/or Representatives should be included with all entries. If you require an agent, please indicate accordingly.

NOTE CLOSING DATE — SATURDAY, 4th MAY, 1963

FINAL LIST OF CATEGORIES

- Thermometers, Temperature Indicators, etc.
- Thermostatic Controls
- Time Switches
- Tools
- Unit Heaters
- Valves
- Valves, Reducing
- Ventilating Panels
- Ventilators
- Waste Disposal Units
- Water Treatment Equipment and Processes
- W.C.'s and Urinals
- Welding Plant and Equipment

READERS ENQUIRY SERVICE AND SUBSCRIPTION FORM

POST TO: IRISH TRADE AND TECHNICAL PUBLICATIONS LTD., CALLAGHAN CHAMBERS, 13/15 DAME STREET, DUBLIN, 2. TELEPHONE 56465/6.

Please send me particulars of the following, as seen in the pages of this Journal.

Name and Address.....
.....

SUBSCRIPTION FORM

Please send me "The Irish Plumber and Heating Contractor" every month until further notice.
I enclose subscription of One Guinea.

Signed
Name of Firm
Address
.....
.....
.....
Date.....

RURAL WATER SUPPLIES

PRIVATE SCHEMES - GROUP SCHEMES - REGIONAL SCHEMES

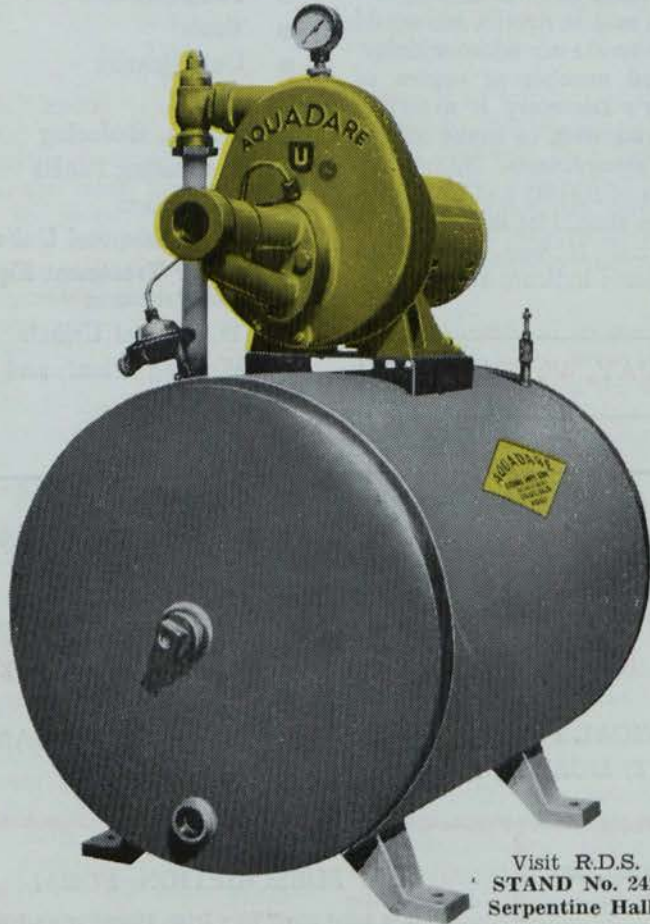

Visit R.D.S.
STAND No. 242
Serpentine Hall

AQUADARE PUMPS

100% Irish design and manufacture.
Water under pressure at all outlets.
Satisfaction guaranteed.

HYDRODARE POLYTHENE TUBING

Manufactured to B.S. 1972/1953
(amended '61) and thus approved
for all Grant-aided water supplies.



* HYDRODARE H.D.

High density polythene tubing to
B.S. 3284/1961 in classes B, C and D.

* UNIDARE HARD P.V.C. PIPE

2"—6" in classes B, C and D.

AQUADARE PUMPS * HYDRODARE POLYTHENE TUBING * UNIDARE Hard P.V.C. Pipe

Completely manufactured by



UNIDARE LIMITED

UNIDARE LIMITED, UNIDARE WORKS, FINGLAS, DUBLIN, IRELAND. TELEPHONE 71801 (13 LINES)