

2012

The 2012 SLL Code for Lighting: the Impact on Design and Commissioning

James Thomas Duff
jimiduff@gmail.com

Follow this and additional works at: <https://arrow.tudublin.ie/sdar>

Recommended Citation

Duff, James Thomas (2012) "The 2012 SLL Code for Lighting: the Impact on Design and Commissioning," *SDAR* Journal of Sustainable Design & Applied Research*: Vol. 1: Iss. 2, Article 4.

doi:<https://doi.org/10.21427/D7FJ0R>

Available at: <https://arrow.tudublin.ie/sdar/vol1/iss2/4>

Creative Commons License



This work is licensed under a [Creative Commons Attribution-Noncommercial 4.0 License](https://creativecommons.org/licenses/by-nc/4.0/)

The 2012 SLL Code for Lighting: The impact on design and commissioning



James Thomas Duff

BENG TECH, BSc

jimiduff@gmail.com

Arup and DIT Research Student



Abstract

In March 2012, the Society of Light and Lighting (SLL) published a new edition of the Code for Lighting. This revision includes a number of changes, which are discussed in detail. Among these changes are a recommendation for mean cylindrical illuminance within enclosed spaces and increased room surface reflectances. A method has been proposed by others to perform in-field measurement of cylindrical illuminance without a dedicated meter. Research in a small test space is undertaken to validate this proposed methodology and comment on its accuracy and practicality. Using the same test space, room surface reflectances are altered to demonstrate their impact on the visual environment. The proposed method for recording cylindrical illuminance is found to be accurate, but tedious and time-consuming to implement. Room surface reflectances were increased and the effect on illuminance on surfaces, luminance, horizontal illuminance, cylindrical illuminance and modelling index was significant for the test room used.

Key Words:

Code for Lighting, cylindrical illuminance, room surface reflectance, visual environment.

Symbols:

E	Illuminance
L	Luminance
ρ	Reflectance
E_m	Maintained illuminance
U_o	Illuminance uniformity
$E_{(\alpha,y,z)}$	Illuminating vector specified by the vector components and x , y and z axes, so that $E_{(\alpha,y,z)} = (E_{(\alpha)}, E_{(y)}, E_{(z)})$
$E_{(\alpha,y)}$	Illuminating vector component on horizontal plane, so that $E_{(\alpha,y)} = (E_{(\alpha)}, E_{(y)})$
E_x	Illuminating vector component on x axis
$ E $	Illumination vector magnitude (lm/m^2). Note that this is a scalar, not a vector. Suffixes are as for E
e	Illumination unit vector, defining the direction of the illumination vector and specified by components on the x , y and z axes.
$E_{(\alpha)}, E_{(-x)}$	Opposed pair of cubic illuminances on the x axis
E_h	Horizontal illuminance
E_{cyl}	Cylindrical illuminance
$'E_{(\alpha)}$	Illuminance due to the illumination vector on a plane normal to the x axis (lm/m^2). $'E_{(\alpha)} = E_{(\alpha)} - E_{(-x)}$ and may be positive or negative depending on the direction of the vector.
$\sim E_{(\alpha)}$	Symmetric illuminance on a plane normal to the x axis (lm/m^2). If $E_{(\alpha)} < E_{(-x)}$ then $\sim E_{(\alpha)} = E_{(\alpha)}$ else $\sim E_{(\alpha)} = E_{(-x)}$
$x, y, z,$	Three mutually perpendicular axes intersecting at a point
$xx/yy/zz$	The percentage reflectance of room surfaces, where xx is the reflectance of the ceiling, yy is the reflectance of the walls and zz is the reflectance of the floor.

Introduction

The Society of Light and Lighting (SLL) and its predecessors, The Lighting Division of the Chartered Institute of Building Services Engineers (CIBSE) and the Illuminating Engineering Society (IES), have published guidance and recommendations on lighting practice since 1936^{[1][2]}. From the beginning, these guidance documents, known as Codes for Lighting, have all contained details of illuminances required for different applications and further qualitative guidance on how to best implement these recommendations^[2]. In 2002, the Committee for European Standardisation (CEN) began providing lighting recommendations and, since then, the Code for Lighting has taken a somewhat different role. The 2012 Code for Lighting draws its quantitative guidance and recommendations directly from the new CEN standards and now acts as a guide on how to interpret these standards and how to implement them in practice.

This paper sets out to identify the changes in the CEN standard EN 12464-1:2011, the resulting changes to the 2012 Code for Lighting, and how these will impact on illumination engineers. Research is conducted to validate a methodology for measuring cylindrical illuminance in-field without a dedicated cylindrical illuminance meter. The impacts of room surface reflectances on the visual environment are demonstrated and the benefits of this highlighted. It is split into three sections as indicated below:

1. Changes to the 2012 edition of the SLL Code for Lighting;
2. In-field measurement of cylindrical illuminance;
3. Effects of increased surface reflectances.

1. Changes to the 2012 edition of the SLL Code for Lighting

1.1 Reflectance of surfaces

The reflectance of room surfaces is usually a parameter that is outside the control of illumination engineers and designers. However, where possible, the designer should try persuading those responsible to aim for reflectances in the range quoted in Table 1^[2]. It is also noted that where possible, the reflectance of major objects should be in the range of 20% – 70%^{[2][3]}. Current recommendations for reflectances have increased the lower limits for walls and ceilings^{[2][3]}. This will increase luminance, help create lighter spaces and reduce energy consumption as the amount of inter reflected illuminance will increase.

1.2 Illuminance on surfaces

In all enclosed spaces, there is now a recommendation for all major surfaces to have the maintained illuminances indicated in Table 2. In some enclosed spaces, such as offices, education, health care, general areas of entrance, stairs, corridors, etc, the walls and ceiling will need to be brighter. In previous SLL recommendations, requirements for illuminances on room surfaces were given as a fraction of the working plane illuminance^{[4][5][6]}. As a rule of thumb,

Table 1 – New and old SLL recommendations for room surface reflectances^{[2][3]}

2012 Ed SLL Code		2009 Ed SLL Code	
Ceiling	70%–90%	Ceiling	60%–90%
Walls	50%–80%	Walls	30%–80%
		Working Plane	20%–60%
Floor	20%–40%	Floor	10%–50%

Table 2 – Illuminances on room surfaces specified in the SLL Code for Lighting 2012 edition^{[2][3]}

Illuminances in enclosed spaces	
Walls	$E_m > 50 \text{ lx with } U_o \geq 0.10$
Ceiling	$E_m > 30 \text{ lx with } U_o \geq 0.10$
Illuminances in enclosed spaces where visual communication is important	
Walls	$E_m > 75 \text{ lx with } U_o \geq 0.10$
Ceiling	$E_m > 50 \text{ lx with } U_o \geq 0.10$

Table 3 – SLL Code for Lighting recommendations for immediate surrounding area illuminances and related task area illuminances^{[2][3]}

Task Area	Immediate surrounding area
>750	500
500	300
300	200
200	E_{task}
150	E_{task}
100	E_{task}
50	E_{task}

these ratios will deliver higher illuminance values on walls and ceilings, and hence a better visual environment^{[2][4][5][6]}. These ratios are not required by EN 12464-1:2011, but the Code recommends their use as best practice^[2].

1.3 Illuminance on the task area

Values detailed in the schedule of lighting criteria in the 2012 edition of the Code now refer to the maintained illuminance over the task area of a reference surface, which can be horizontal, vertical or inclined^[2]. This is a major change from previous editions of the Code. *It is no longer recommended to provide task illuminance for the entire space.* Where the location of a task is unknown, EN 12464-1:2011 recommends that the entire space be uniformly illuminated to a level chosen by the designer^[3] (Fig 1). However, the current Code recommends that where the location of the task is unknown, it is still very wasteful to illuminate the entire space for one particular task carried out in a small area^[2]. Possible solutions would be the provision of task lighting or individually

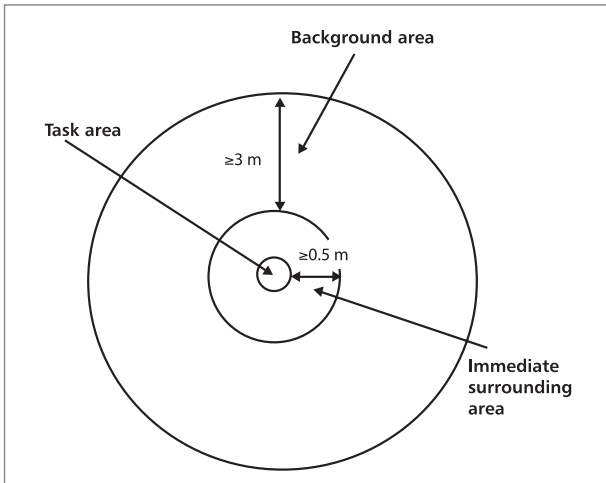

Fig 1 – Task, immediate surrounding and background area dimensions^{[2][3]}.

dimnable luminaires that give added flexibility to a lighting control system.

1.4 Illuminance on the immediate surrounding area

Large spatial variations in the illuminances surrounding the task area can lead to visual stress and discomfort^[7]. EN 12464-1:2011 defines the immediate surrounding area as a band with a width of at least 0.5m around the task area in the visual field^[3]. Values of illuminance in the immediate surrounding area can be less than that of the task area, but should not be less than the values indicated in Table 3.

1.5 Illuminance on the background area

In indoor workspaces, a large part of the area surrounding an active task needs to be illuminated. EN 12464-1:2011 defines the background area as a border at least 3m wide adjacent to the immediate surrounding area within the limits of the space^[3]. This area should have a maintained illuminance not less than one third of the immediate surrounding area^{[2][3]}.

1.6 Mean cylindrical illuminance in the activity space

In addition to lighting the task, the volume of space that is occupied by people should be lit. This illumination is required to

highlight objects, reveal texture, improve the appearance of people within the space and aid with the integration of daylight and electric lighting^{[2][3][8]}. This is satisfied by providing an adequate level of mean cylindrical illuminance in the activity space. The use of mean cylindrical illuminance in the Code is new and is stated as a *big step forward in recognising the importance of the visibility of objects, particularly peoples' faces, within a space*^[2]. Values of cylindrical illuminance should be taken at 1.2m or 1.6m, dependent upon whether people might be sitting or standing in the space^{[2][3]}. Values of maintained cylindrical illuminance recommended in the Code are not less than 50 lx with $U_0 \geq 0.10$ ^{[2][3]} and for areas where visual communication is important (office meeting rooms, teaching spaces, etc), maintained cylindrical illuminance should be not less than 150 lx with $U_0 \geq 0.10$ ^{[2][3]}.

1.7 Modelling

The architectural details of an interior can be enhanced when its structural features, the people and objects within it are lit so that form and texture are revealed pleasingly. Lighting should not be too diffuse or it will appear bland and may not reveal necessary detail, nor should it be too directional or it will produce harsh shadows^{[2][3]} (Fig 2). Modelling describes the balance between diffuse light and direct light. The ratio of cylindrical to horizontal illuminance at a point is an indicator of modelling and known as the modelling index^[3]. EN 12464-1:2011 suggests that a good indicator of modelling is a modelling index between 0.3 and 0.6^[3].

Research

Of the changes outlined, a major addition is the introduction of cylindrical illuminance. Some short research is carried out to investigate how this will affect illumination engineers when taking in-field measurements. A second change is the recommendation of increased room surface reflectances. There is also a short demonstration of how altering room surface reflectances will impact the visual environment experienced by end users.



Fig 2 – Modelling of a bust by different light distributions. From left to right, lighting is completely diffuse, strong down-lighting and a combination of directional and diffuse lighting^[2].

2. In-field measurement of cylindrical illuminance

2.1 Introduction

Cylindrical illuminance is defined in the SLL Code for Lighting as the *total luminous flux falling on the curved surface of a very small cylinder located at a specified point, divided by the curved surface area of the cylinder*^[2]. Its introduction to the recommended lighting criteria in the SLL Code will provide a new challenge for illumination engineers as there will come a time when they must take in-field measurements to compare a design against an installation. Instruments exist for the direct measurement of cylindrical illumination, but their cost is high and probably unjustifiable for most consulting engineering companies or small lighting design firms. An alternate method for obtaining cylindrical illuminance does exist. It comprises of mounting a small, solid cube at the measurement point and measuring successively the illuminance on each of the faces of this cube. Rowlands and Loe^[9] have used this method previously. They did not comment on the difficulty of measurement, but others have suggested that it may be tedious and more difficult than it sounds^[10].

The premise of this research is that Dialux simulation software is accurate. This is based on previous research^{[11]-[18]}. The aim is to investigate if in-field measurements using the methodology described later will be accurate when compared to Dialux simulated values under closely-controlled parameters.

2.2 Background

In order for illumination engineers to take in-field measurements for cylindrical illuminance without a dedicated cylindrical illuminance meter, they must fully understand illumination vectors and in particular, cubic illumination^{[10][19]}. This is described in complete detail elsewhere^{[10][19]}, but a brief overview is given below.

2.2.1 The illumination vector

The illuminance received at a point may be considered a vector. Fig 3 shows the illuminance due to source S^{[10][19]}. The vector E is the

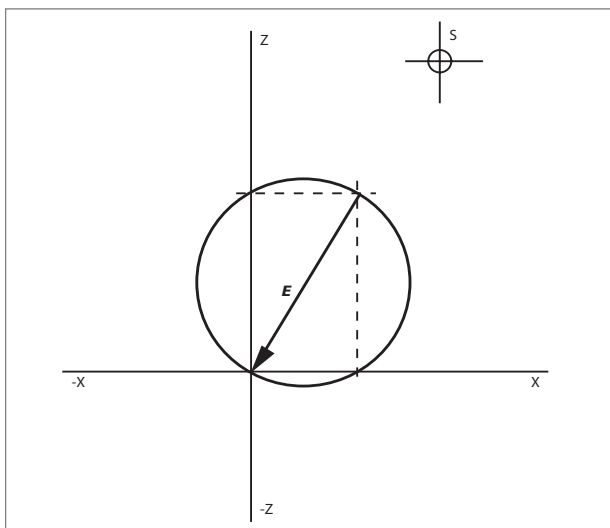

Fig 3 – The illumination vector.

illuminance vector and the distance from the origin of the axes and the circle is the relative illuminance falling on a plane, normal to the line joining the origin to the circle^{[10][19]}. The situation where there is only one light source illuminating a point is rare and in general, there is light falling from a number of different sources onto the point^{[10][19]}. If this is the case, then the illumination vector will become the sum of two or more vectors. As a vector may be the sum of more than one component, it is possible to analyse vectors into a series of components.

2.2.2 Cubic illuminance

Cubic illumination is *the specification of the directional distribution of incident luminous flux at a point in space, in terms of pairs of opposed planar illuminances, normal to three mutually-perpendicular axes intersecting a certain point*^[10]. Put more simply, it is the illuminance falling on the six faces of an indefinitely small cube, as indicated in Fig 4.

When taking in-field measurements, the six values obtained are $E_{(+x)}$, $E_{(-x)}$, $E_{(+y)}$, $E_{(-y)}$, $E_{(+z)}$ and $E_{(-z)}$. Using equations (1) - (8), it is possible to calculate the vector (E) and the symmetric ($\sim E$) components.

$$E_{(x,y,z)} = (E_{(x)}, E_{(y)}, E_{(z)}) \quad (1)$$

$$E_{(x)} = E_{(+x)} - E_{(-x)} \quad (2)$$

$$E_{(y)} = E_{(+y)} - E_{(-y)} \quad (3)$$

$$E_{(z)} = E_{(+z)} - E_{(-z)} \quad (4)$$

$$\sim E_{(x,y,z)} = (\sim E_x, \sim E_y, \sim E_z) \quad (5)$$

$$\sim E_{(x)} = \min (E_{(+x)}, E_{(-x)}) \quad (6)$$

$$\sim E_{(y)} = \min (E_{(+y)}, E_{(-y)}) \quad (7)$$

$$\sim E_{(z)} = \min (E_{(+z)}, E_{(-z)}) \quad (8)$$

The symmetric component of the vector is the quantity of light that is equally received on each side of the cube and the vector components are the differences between each pair of opposite sides of the cube^{[2][10][19]}. From the above values and using equations (9) - (13), it is possible to calculate the cylindrical illuminance at a point.

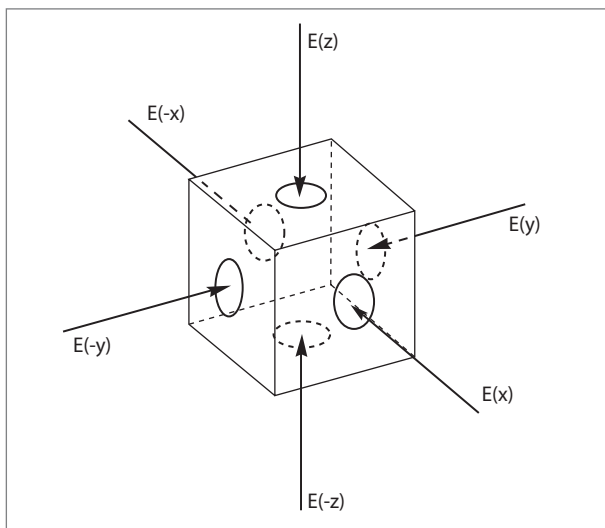

Fig 4 - The illuminances on the six faces of a cube.

$$|E_{(\alpha,y,z)}| = (E_{(\alpha)}^2 + E_{(y)}^2 + E_{(z)}^2)^{0.5} \quad (9)$$

$$e_{(\alpha)} = \frac{E_{(\alpha)}}{|E_{(\alpha,y,z)}|} \quad (10)$$

$$e_{(y)} = \frac{E_{(y)}}{|E_{(\alpha,y,z)}|} \quad (11)$$

$$e_{(z)} = \frac{E_{(z)}}{|E_{(\alpha,y,z)}|} \quad (12)$$

$$E_{cyl} = \frac{|E|e_{(\alpha,y)}}{\pi} + \frac{(\sim E_{(\alpha)} + \sim E_{(y)})}{2} \quad (13)$$

A sample calculation is carried out in Appendix 1.

2.3 Methodology

The room shown in Fig 5 was used for all testing. It is 6.1m long, 4.5m wide and 3.2m high, walls and ceiling are painted concrete and it has no windows, so daylight and stray light are excluded. There are four surface-mounted luminaires. Each luminaire contains one 35W T5 linear fluorescent lamp.

1. Room dimensions were measured.
2. A grid was marked on all room surfaces and reflectances were obtained using an illuminance meter, a luminance meter and equation (14).

3. New lamps were installed to give an accurate estimate of lumen output.
4. The light loss factor (LLF) in the Dialux model was set to 1.0 to best match the lumen output of the new lamps.
5. Lamp optics, luminaire optics and light output ratio (LOR) were verified by manufacturer.
6. A grid of nine points (Fig 5) was marked out on the floor.
7. A small cube was attached to a wooden pole, which was 1.6m in length and had a bracket fitted to its base to ensure that the cube remained in the correct location above measurement points.
8. The cube was always positioned with its sides parallel to major room surfaces.
9. On each face of the cube, a value ($E_{(+x)}$, $E_{(-y)}$, etc) was marked to allow ease of recording, excluding the face of the cube parallel with the floor ($E_{(-z)}$). This face of the cube was used to attach the pole.

Equation (14) was used for calculating room surface reflectances^[20]. It uses the assumption that the surface being measured is a perfect diffuser. This will not be definitively accurate, but it is a common pragmatic solution for in-field research measurements.

$$L = \frac{\rho E}{\pi} \quad (14)$$

2.4 Results

The reflectance of room surfaces are given in Table 4. In-field values and simulated values for cylindrical illuminance at each grid point are given in Table 5.

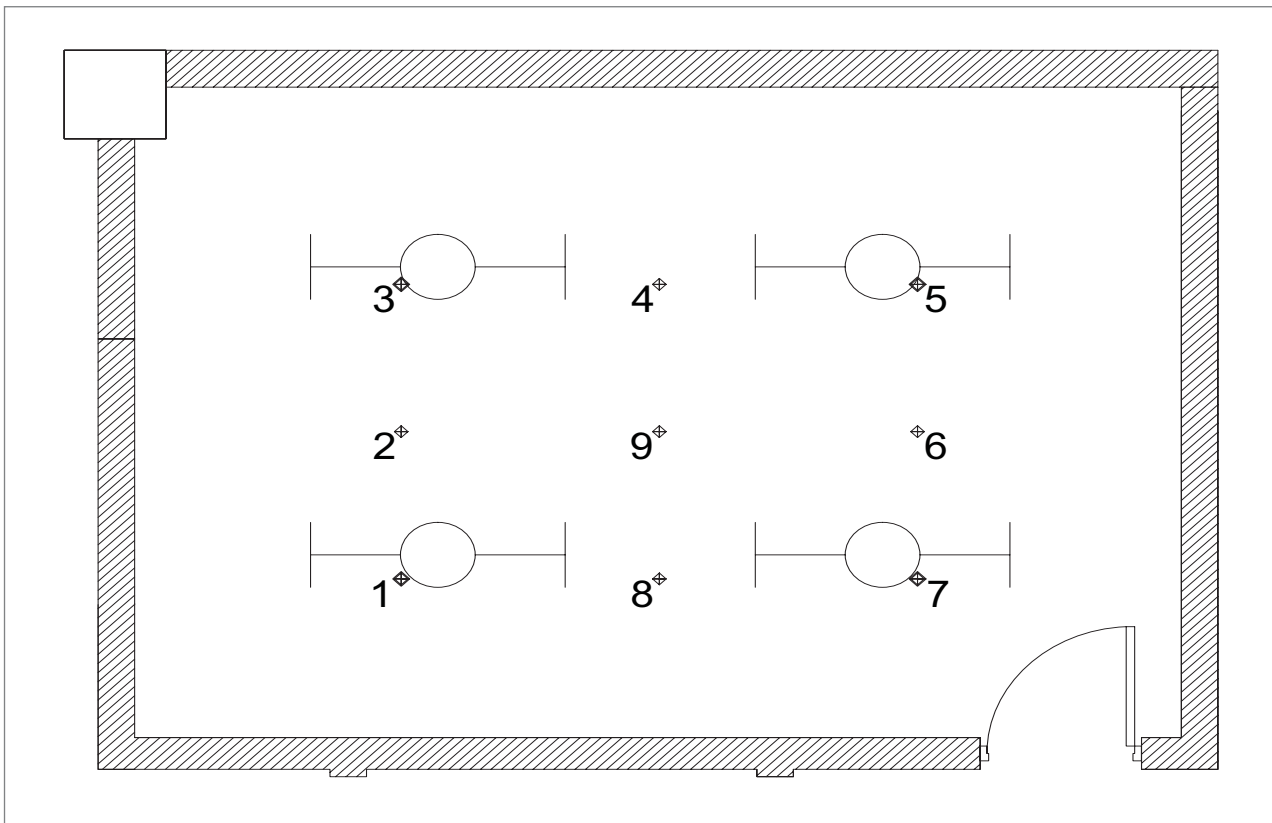

Fig 5 – Test room layout showing location of luminaires and grid or measurement point.

Table 4 – Reflectance values recorded for room surfaces

Room surface reflectances (%)	Ceiling	Walls	Floor
	44	31	14

2.5 Discussion and analysis

2.5.1 Cylindrical illuminance: in-field vs. simulated

Table 5 compares levels of cylindrical illuminance at each of the nine grid points. It is clear that measured in-field values were similar to that generated in Dialux simulation software, which is taken as an accurate reference base for this research. The average percentage error between measured values and simulated values was -2%. The small errors could be due to a number of variables. These slight inaccuracies in manufacturer lumen output; luminaire optical files or LOR; incorrect alignment of the cube used for measurements; inconsistent mounting of the illuminance meter to the faces of the cube; and possible discrepancies in calibration of instruments.

Despite the large number of variables, the results produced give a strong indication that by following the measurement procedure outlined, in-field measurement of cylindrical illuminance without a dedicated cylindrical illuminance meter can be carried out with an appropriate degree of accuracy for verifying an installation, compared to design data generated in Dialux simulation software.

2.5.2 Difficulties and nuances in measurement

The cube and the apparatus used to mount the cube were constructed from standard household items. Specifically, a small rubix cube and a wooden pole with a bracket attached to its base. This bracket had adjustable legs and was used to ensure that the cube remained at the correct height and parallel with room surfaces while the author recorded measurements. A spirit level was used to ensure that the measurement cube was at the desired, precise orientation each time it was moved to a new location. All of these actions were taken to ensure that variables were reduced and measured values would best reflect simulated values. The downsides to this are the extensive time taken and the tedious nature of recording results. An approximate timeframe for each grid point was about 15-20 minutes, a little over two and a half hours for nine grid points. When verifying a real world installation, measurement points must be used that match design software^{[2][3]}. This is important as for a room the size of the test room used, Dialux defaults to a total of 63 grid points, meaning that 63 grid points would have to be measured in-field. If each point took the same amount of time as experienced by the author, this would become an estimated two days of measurements.

As an aside and demonstrated in full in Appendix 1, the average of the four vertical sides of the cube ($E_{(+x)}$, $E_{(+y)}$, $E_{(-x)}$, $E_{(-y)}$) provides an indicator of levels of cylindrical illuminance, but the percentage error experienced is high enough that it should not be used to verify installations.

Table 5 – Comparison of cylindrical illuminance from in-field values against those generated in Dialux simulation software

Grid Point No.	E_{cyl} In-field (lx)	E_{cyl} Simulated (lx)
1	53	61
2	77	79
3	59	64
4	75	76
5	59	64
6	77	79
7	52	60
8	72	75
9	84	78
Average	68	71

Table 6 – Room surface reflectances before and after cleaning and painting

Before cleaning and painting (%)	Ceiling	Walls	Floor
	44	31	14
After cleaning and painting (%)	Ceiling	Walls	Floor
	81	64	14

3. Effects of increased surface reflectances

3.1 Introduction

In addition to illuminating a task, the space which houses the task should also be illuminated. As discussed in 1.6, this is satisfied by providing adequate levels of cylindrical illuminance. Cylindrical illuminance requires luminous flux from directions other than the vertical axis. Room surface reflectances have a direct impact on luminance from room surfaces (equation 14) and hence, luminous flux emanating from room surfaces, cylindrical illuminance and the visual environment.

3.2 Methodology

To demonstrate this, the test room was cleaned and then painted to increase reflectances. Colours used previously were dark yellow/browns and when cleaned and painted, the new colours chosen were bright white for the ceiling and light white/yellow for the walls.

By changing surface colours, reflectances were increased as indicated in Table 6. Once the new surface reflectances had been established, all necessary steps set out in the methodology were carried out again.

3.3 Results

Table 7 gives a summary of the effects that increasing surface

Table 7 – Effects of increased reflectances on illuminance on walls, luminance from walls, horizontal illuminance, cylindrical illuminance and modelling index

	Reflectances at 44/31/14	Reflectances at 84/65/14	Percentage increase (%)
Average illuminance on walls (lx)	43	84	95
Average luminance from walls (cd/m ²)	8.5	26	206
Average horizontal illuminance (lx)	223	276	24
Average cylindrical illuminance (lx)	68	115	69
Modelling Index	0.30	0.42	37

reflectances had on the illuminance on walls, luminance from walls, horizontal illuminance, cylindrical illuminance and modelling index. All values are the mean of measured values over nine grid points.

3.4 Discussion and analysis

3.4.1 Illuminance on walls

Increased surface reflectances will increase luminance within a space, as defined in equation (14). When surface reflectances were increased, the average illuminance on the walls of the test room moved from 43 lux to 84 lux, a 95% increase. The new edition of the SLL Code recommends that illuminance on walls should be greater than 50 lux. It can be seen that before reflectances were changed, the mean illuminance on the walls of the test room were below this value, but once reflectances were increased, the mean illuminance on the walls was in excess.

3.4.2 Luminance

Luminance is defined as *luminous flux per unit solid angle transmitted by an elementary beam passing through the given point and propagating in the given direction, divided by the area of a section of that beam normal to the direction of the beam and containing the given point*^[2]. More simply, it is the illuminance produced by the beam of light on a surface normal to its direction, divided by the solid angle of the source as seen from the illuminated surface. Luminance is used as it represents a measurable physical quantity that relates to the perceived sensations of brightness and lightness.

Increasing surface reflectances as indicated in Table 6 showed a resulting 206% increase in luminance measured on the walls of the test room. This would produce a visual environment that is perceived to be much brighter, despite having the same amount of luminous flux emitted from the luminaires.

3.4.3 Horizontal illuminance

Table 7 shows the increase in horizontal illuminance after room

surface reflectances were increased. Increasing reflectances as indicated in Table 6 produced a 24% increase in mean horizontal illuminance, from 223 lux to 276 lux.

3.4.4 Cylindrical illuminance

Mean cylindrical illuminance increased from 68 lux to 115 lux, an increase of 69%. As given in equation (14), room surface reflectance has a direct impact on the luminance of room surfaces. This in turn affects quantities of illuminance emitted from room surfaces and falling upon objects, peoples' faces and task surfaces within the space. It can be concluded from this that where a ceiling mounted luminaire arrangement or design cannot be changed, an alternative method of increasing cylindrical illuminance is to increase room surface reflectances by cleaning and painting.

3.4.5 Modelling index

Modelling is the ratio of diffuse light against the direct light at the same point. Modelling index provides an indicator of modelling within a space and is defined by the ratio of horizontal illuminance to cylindrical illuminance ($E_h:E_{cyl}$). EN 12464-1:2011 recommends that a good indicator of modelling is a modelling index between 0.3 and 0.6. It stands to reason that as levels of cylindrical illuminance experienced a larger percentage increase than horizontal illuminance, modelling index also increased. Values rose from 0.3 to 0.42, an increase of 37%. From results, it can be concluded that where luminaires are ceiling mounted, increasing room surface reflectances will generally increase modelling within a space.

Conclusions

Changes in the CEN standard EN 12464-1:2011 and the resultant changes to the SLL Code for Lighting have been discussed and the main impacts for illumination engineers have been examined.

Research conducted indicated that using the measurement procedure described, measured in-field values of cylindrical illuminance will produce a relatively small percentage error compared to those generated in Dialux simulation software. This would indicate that this method is acceptable for the verification of a design in Dialux software against a real-world installation. The tedious nature of recording results has been discussed and the time implications demonstrated. These were found to be problematic.

Room surface reflectances within a test room were increased from 44/31/14 to 81/65/14. This was done solely by cleaning and painting. Illuminance on walls increased by 95%, luminance emitted from walls increased by 206%, horizontal illuminance increased by 24%, cylindrical illuminance increased by 69% and hence, modelling index increased by 37%. Consequently, the impact of room surface reflectances on the visual environment of a small space has been shown to be very significant. As such, it is suggested that if it is within the scope of the illumination engineer to influence room surface reflectances and exact values are known at design stage, then there is potential for substantial energy reduction with nothing more costly than a coat of high reflectance paint.

Acknowledgements

The author acknowledges the MEP group at ARUP Dublin and staff at the School of Electrical Engineering Systems in the Dublin Institute of Technology.

References

[1] Loe, D.L. and McIntosh, R. 2009. *Reflections on the last One Hundred Years of Lighting in Great Britain*. The Society of Light and Lighting as part of CIBSE. Page Bros. Norwich

[2] Society of Light and Lighting. 2012. *The SLL Code for Lighting*. CIBSE. Page Bros. Norwich

[3] Committee of European Standards. 2011. EN 12464-1:2011. *Light and Lighting - Lighting of workplaces. Part 1: Indoor Workplaces*. London: CEN.

[4] The Society of Light and Lighting (SLL). 2009. *The SLL Code for Lighting*. ISBN-978-906846-07-7. London: SLL

[5] The Society of Light and Lighting (SLL) 2011. *SLL Lighting Guide 5: Lighting for education*. ISBN 978 1 906846 17 6, London: CIBSE

[6] Society of Light and Lighting (SLL) *Lighting Guide 7: Office lighting*, London: CIBSE

[7] Pellegrino, A. 1999. *Assessment of Artificial Lighting Parameters in a Visual Comfort Perspective*. *Lighting Research and Technology* 31:107. CIBSE: London

[8] A Nassar, MM El-Ganainy, FA Moktader, SM El-Kareem, and MA Haridi. *Cylindrical Illuminance and its Importance in Integrating Daylight with Electric Light*. *Lighting Research and Technology*, September 2003; vol. 35, 3: pp. 217-222

[9] Rowlands E and Loe D. 1975. *Preferred Illuminance Distribution in Interiors*. Proc 18th CIE Session, London P-75-17

[10] Cuttle, C. 1997. *Cubic Illumination. Lighting Research and Technology* 1997 29: 1

[11] Puech C, Sillion F and Vedel C. Prec of 1990 Symposium on interactive 3D graphics. P51-57 ISBN: 0-89971-351-5

[12] Maamari F, Fontoynt M and Andra N. Application of the CIE test cases to assess the accuracy of lighting computer programs. *Energy and Buildings*. Vol 38 Issue 7. July 2006. P 869-877

[13] L Bellia A Cesarano and S Sibilio. 1994. Daylighting contribution in interior lighting: Experimental verification of software simulation results. *Lighting Research and Technology*. Vol 26-2. P99-105

[14] DHW Li, CCS Lau and JC Lam. 2004. Predicting daylight illuminance using computer simulation techniques. *Lighting Research and Technology*. Vol 36-2. P113-128

[15] Geebelen B, Van Der Voorden M and Neuckermans H. 2005. Fast and accurate simulation of long term daylight availability using the radiosity method. *Lighting Research and Technology*. Vol 37-4. P295-310

[16] Mardaljevic J. 1995. Validation of a lighting simulation software program under real sky conditions. *Lighting Research and Technology*. Vol 27-4. P181-188

[17] Maamari and Fontoynt. 2003 Analytical tests for investigating the accuracy of lighting programs. *Lighting Research and Technology*. Vol 35-3. P225-239

[18] J Mardaljevic. 2000 Simulation of annual daylighting profiles for internal illuminance. *Lighting Research and Technology*. Vol 32-3. P111-118

[19] Cuttle, C. 2003. *Lighting by Design*. London: Architectural Press.

[20] The Society of Light and Lighting (SLL) (2001) *SLL Lighting Guide 11: Surface reflectance and colour*. ISBN 1 903287 14 6, London: CIBSE

Appendix 1

The example below demonstrates how to derive E_{cyl} from the illuminance measurements taken on the six faces of a small cube.

Measured in-field data

$E_{(+x)}$ 320	$E_{(-x)}$ 140
$E_{(+y)}$ 180	$E_{(-y)}$ 180
$E_{(+z)}$ 440	$E_{(-z)}$ 90

Resultant vector and symmetric components using equations (1) - (8)

$E_{(x)}$ 180	$\sim E_{(x)}$ 140
$E_{(y)}$ 0	$\sim E_{(y)}$ 180
$E_{(z)}$ 350	$\sim E_{(z)}$ 90

The magnitude of the illumination vector $E_{(x,y,z)}$:

$$|E_{(x,y,z)}| = (\sqrt{E_x^2 + E_y^2 + E_z^2})^{0.5} = (180^2 + 350^2)^{0.5} = 394 \text{ lx}$$

Then vector direction is defined by $e_{(x,y,z)}$, where:

$$e_{(x)} = \frac{E_{(x)}}{|E|} = \frac{180}{394} = 0.457$$

$$e_{(y)} = \frac{E_{(y)}}{|E|} = \frac{0}{394} = 0$$

$$e_{(z)} = \frac{E_{(z)}}{|E|} = \frac{350}{394} = 0.889$$

$$e_{(x,y,z)} = (0.457, 0, 0.889)$$

To find magnitude of the illumination vector $E_{(x,y)}$:

$$|E_{(x,y)}| = (\sqrt{E_x^2 + E_y^2})^{0.5} = (180^2 + 0^2)^{0.5} = 180 \text{ lx}$$

$$e_{(x)} = \frac{E_{(x)}}{|E|} = \frac{180}{180} = 1$$

$$e_{(y)} = \frac{E_{(y)}}{|E|} = \frac{0}{180} = 0$$

$e_{(x,y)}$ is the two dimensional unit vector $e_{(z)} = 0$

$$e_{(z)} = \frac{E_{(z)}}{|E|} = \frac{0}{180} = 0$$

$$e_{(x,y,z)} = (1, 0, 0)$$

Then, using equation (13):

$$E_{cyl} = 394 \times \frac{0.4555}{\pi} + 160 = 219 \text{ lx}$$

Using the average of the four sides of the cube:

$$E = \frac{E_{(+x)} + E_{(-x)} + E_{(+y)} + E_{(-y)}}{4} = 205 \text{ lx}$$