

2018

A Bioreactor for Conditioning Tissue Engineered Heart Valves

Claire M. Brougham

Technological University Dublin, claire.brougham@dit.ie

Francisco Almeida

Technological University Dublin

Fergal J O'Brien

Royal College of Surgeons in Ireland

Follow this and additional works at: <https://arrow.tudublin.ie/engschmecoht>



Part of the [Civil and Environmental Engineering Commons](#)

Recommended Citation

Almeida, F., O'Brien, FJ., Brougham, CM.(2018) A bioreactor for conditioning tissue engineered heart valves. *24th Annual Conference of the Section of Bioengineering of the Royal Academy of Medicine in Ireland*, Johnstown House Estate, Ireland, January 2018.

This Other is brought to you for free and open access by the School of Mechanical and Design Engineering at ARROW@TU Dublin. It has been accepted for inclusion in Other resources by an authorized administrator of ARROW@TU Dublin. For more information, please contact yvonne.desmond@tudublin.ie, arrow.admin@tudublin.ie, brian.widdis@tudublin.ie.



2018-1

A bioreactor for conditioning tissue engineered heart valves

Francisco Almeida

Fergal J. O'Brien

Claire M. Brougham

Follow this and additional works at: <https://arrow.dit.ie/engschmecon>

 Part of the [Engineering Commons](#)

This Conference Paper is brought to you for free and open access by the School of Mechanical and Design Engineering at ARROW@TU Dublin. It has been accepted for inclusion in Conference Papers by an authorized administrator of ARROW@TU Dublin. For more information, please contact yvonne.desmond@dit.ie, arrow.admin@dit.ie, brian.widdis@dit.ie.



Early Stage Researcher (PhD Year 1)?

Post-Doctoral Researcher/Senior Researcher/PI?

Entry for the Engineers Ireland Biomedical Research Medal?

Corresponding author has completed PhD and would like to review Binl abstract submissions?

Please place an X in any appropriate categories

A BIOREACTOR FOR CONDITIONING TISSUE ENGINEERED HEART VALVES

Almeida, F.^{1, 2}, O'Brien, F.J.^{2, 3, 4}, Brougham, C.M.^{1, 2}

¹ School of Mechanical and Design Engineering, Dublin Institute of Technology

² Tissue Engineering Research Group, Dept. of Anatomy, Royal College of Surgeons in Ireland

³ Advanced Materials and Bioengineering Research (AMBER) Centre, RCSI & TCD

⁴ Trinity Centre for Bioengineering, Trinity College Dublin

email: francisco.almeida@mydit.ie

INTRODUCTION

Globally over 100 million people are affected by heart valve (HV) related diseases and 300,000 HV replacements are required annually (Kheradvar et al., 2015). While HV replacement is a common procedure for adult patients, the inability of mechanical or bioprosthetic HVs to grow makes replacement surgery the final choice for paediatric patients, as multiple revision surgeries are often required. Tissue engineered heart valves (TEHVs) are the new paradigm and promise integration with the native vasculature, thereby facilitating growth and remodelling *in vivo*. This could eliminate paediatric patients' need for revision surgeries.

The TE approach we are interested in combines autologous cells with a fibrin-collagen-glycosaminoglycan scaffold (Brougham et al., 2017, 2015), and this construct is subsequently conditioned using a bioreactor. The bioreactor simulates the mechanical action of the heart, encouraging the directional proliferation of cells and the development of a biomimetic extracellular matrix. While many HV bioreactors have been developed, the ideal set up and conditioning regime to create a fully functional TEHV remains unknown. Therefore, the long term goal of this project is create a TEHV from the previously developed scaffolds (Brougham et al., 2017, 2015) suitable for *in vivo* trials. The initial project aim was to design a bioreactor that was capable of conditioning HVs using a range of parameters.

DESIGN REQUIREMENTS

The design requirements of the bioreactor included the ability to mimic both an adult and a neonate heart (heart rates 30 to 200 bpm, flow through the HV of 25 to 100 ml/beat and a pressure drop of 13 to 25 mmHg across the valve). The bioreactor must be fabricated from non-cytotoxic materials and be easy to sterilise (using ethylene oxide and/or autoclaving). It must facilitate gas exchange and media exchange while being housed inside an incubator and must remain sterile throughout the culture period. The delivery of the HV into the bioreactor must be accomplished using aseptic technique, the valve must be suitably fixed in place and be visible throughout the culture period. These design requirements were met in the proposed concept (Figure 1).

DESIGN CONCEPT

The bioreactor houses the HV in a central position between the pulmonary (3) and ventricular (2) chambers. Media is pumped through the valve by the displacement of a silicone membrane (f) and secured in a stainless steel

base (1). This is achieved using a magnetic actuator, controlled using Labview. Silicone tubing will allow displaced media to circulate between polypropylene connectors (a) and (b), while a peristaltic pump will pump media between connectors (c) and (d). The main body (2, 3) and lid (4) of the bioreactor will be fabricated from PMMA with the design of the lid allowing clear observation of the HV leaflets. A compliance chamber will be attached to connector (e) to simulate arterial expansion and a syringe filter to promote gas exchange.

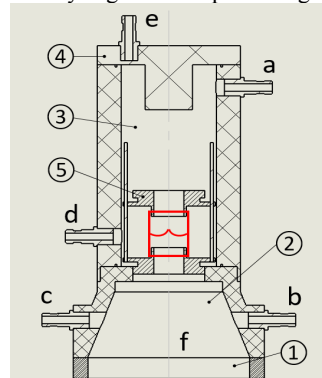

Figure 1 Bioreactor design showing a heart valve in red. Bioreactor contains a base (1), ventricular chamber (2), pulmonary chamber (3), lid (4), heart valve support (5), connectors (a, b, c, d, and e) and silicone membrane (f).

DISCUSSION

This bioreactor design is loosely based on the conceptual design proposed by Hoerstrup et al. (2000), and uses elements from the bioreactor designed by Moreira et al. (2014). However, unlike those designs, here the ventricular chamber acts as a nozzle to direct the flow towards the HV. Operating parameters will be validated using a mechanical HV and measuring the pressure drop across the valve using pressure transducers. A flow sensor will measure the shear flow through the HV. Additionally, cytotoxicity tests are required to validate the choice of materials while sterility tests are required to validate its operating conditions. In time, this bioreactor will be employed to condition TEHVs using a variety of conditioning regimes.

REFERENCES

- Brougham *et al.*, *Adv Healthcare Materials* 6:21 2017.
- Brougham *et al.*, *Acta Biomaterialia* 26: 205-214, 2015.
- Hoerstrup *et al.*, *Tissue Engineering* 6: 75-79, 2000.
- Kheradvar *et al.*, *Annals of Biomed Eng* 43:4 2015.
- Moreira *et al.*, *Tissue Engineering* 20: 741-748, 2014.

Funding: DIT Dean of Graduate Research School Award