

8-1-1962

The Irish Plumber and Heating Contractor, August 1962 (complete issue)

Follow this and additional works at: <https://arrow.tudublin.ie/bsn>



Part of the [Civil Engineering Commons](#), [Construction Engineering Commons](#), and the [Construction Engineering and Management Commons](#)

Recommended Citation

(1962) "The Irish Plumber and Heating Contractor, August 1962 (complete issue)," *Building Services Engineering*: Vol. 2: Iss. 5, Article 1.

doi:10.21427/D79T3D

Available at: <https://arrow.tudublin.ie/bsn/vol2/iss5/1>

This Article is brought to you for free and open access by the Journals at ARROW@TU Dublin. It has been accepted for inclusion in Building Services Engineering by an authorized editor of ARROW@TU Dublin. For more information, please contact arrow.admin@tudublin.ie, aisling.coyne@tudublin.ie, vera.kilshaw@tudublin.ie.

THE IRISH PLUMBER & HEATING CONTRACTOR



**MRS
1970
KNOWS WHAT
SHE WANTS**

And she knows just where to get it. Because the hard hitting advertising which first sells her on the idea of installing Shell and BP Housewarming also tells her of the superb service offered by her local Appointed Installer. The special Shell and BP Appointed Installer's sign is prominently featured in each advertisement to help her remember it.

There are hundreds of Mrs. 1970's. All looking for the Irish Shell and BP Limited Appointed Installer's sign — the sign which they know means prompt efficient service. Hundred's of Mrs. 1970's — hundreds of systems to install and service. It's obviously very good business to give Mrs. 1970 what she wants!

SHELL AND BP HOUSEWARMING

THE ORIGINAL SCHEME FOR OIL-FIRED CENTRAL HEATING IN THE HOME

IRISH SHELL AND BP LIMITED
SHELL-BP HOUSE,
13-16 FLEET ST., DUBLIN 2.

IRISH SHELL AND BP LIMITED



HOUSEWARMING PLAN

WATER ON TAP

ACT NOW— AND DISCOVER HOW LITTLE IT COSTS!

Aquadare Automatic Pumps are fully automatic and give water more pressure at all outlets. No attention or lubrication required. Satisfaction guaranteed. Hydrodare Polythene tubing is manufactured to B.S. 1972/1953 and is thus approved for all Grant-aided water schemes.



AQUADARE PUMPS HYDRODARE TUBING

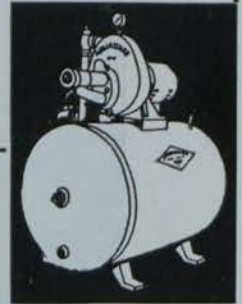

Low density Polythene. BS.1972/1953. 500 ft. coils.

HYDRODARE H.D. Classes B, C, & D.

High density Polythene. BS.3284/1961. 500 ft. coils.

UNIDARE HARD P.V.C. PIPE Classes B, C, & D.

Dept. Local Gov. prov. Spec. June '58. 2" to 6".

Without obligation, please send me illustrated Brochure/Price Lists on Aquadare Pumps, Hydrodare Tubing.

NAME

ADDRESS

 **POST
THIS COUPON
TO-DAY**



UNIDARE LIMITED, FINGLAS, DUBLIN 11

Telephone 71801 (13 lines)



We are pleased to have been associated for over 25 years with Plumbing and Central Heating Engineers throughout the country.

Deliveries Everywhere

**'Quasi-Arc' Electrodes And
Welding Plant**

**THE MOST OUTSTANDING NAME IN THE
FIELD OF ELECTRIC ARC WELDING**

**'British Oxygen' Equipment
Blowpipes & Cutters**

**FOR SAFETY, ECONOMY, DEPENDABILITY.
THE MOST POPULAR PRODUCTION AND
MAINTENANCE TOOL IN INDUSTRY.**

Why Not Consult Us? Phone 55471

**Industrial Gases (I.F.S.) Ltd.
BLUEBELL, INCHICORE, DUBLIN**

BUDERUS CAST IRON BOILERS

**From 46,000 B.T.U.s
to 3,000,000 B.T.U.s**

- Buderus boilers are gaining on others for high efficiency, pleasing appearance, competitive prices and especially quick delivery. (Many sizes now from Dublin stock).



***Write for our
stock price
list***

Sole Agents:

QUADRANT ENGINEERS

6 Mount St. Crescent, Dublin, 2.

Telephone 61492.

BUDERUS - QUADRANT - BUDERUS - QUADRANT - BUDERUS - QUADRANT - BUDERUS - QUADRANT



S & L new High Density Polyethylene pipe sets a new standard of efficiency and economy in handling and application. S & L High Density pipe is adaptable, durable and reliable; it is extremely tough but flexible and is the ideal pipe for cold water and air supply lines. Its resistance to corrosion makes this pipe the natural choice of the engineer when confronted with problems of conveying acids and chemical effluents in the works or in the laboratory. Round the clock quality control and intensive laboratory research combine to give a pipe of constant quality you will find completely reliable, which, need it be said, is made to British Standard specifications. Look for this mark S & L, it is your guarantee of quality and service.



New! High Density Polyethylene Pipe

Fully approved by Department of Local Government and
Dublin Corporation.

STEWART AND LLOYDS OF IRELAND, LTD.
EAST WALL ROAD, DUBLIN 3

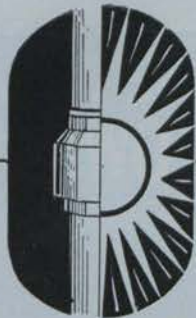

Vol. 2. No. 5.

The only publication in Ireland for the craftsman plumber and contractor, the heating, ventilation, insulation, air conditioning and refrigeration engineer and contractor, the electrical contractor, supplier, manufacturer and wholesaler of fittings and equipment for the trades.

Published monthly by Irish Trade & Technical Publications. Annual subscription, 21/-, post free. Single copies, 1/9, post free.

Editorial and advertising offices:

Callaghan Chambers, 13/15 Dame Street, Dublin, 2. Tel.: 56466, and 133 Royal Avenue, Belfast. Tel.: Belfast 22796.

AUGUST, 1962.



THE IRISH PLUMBER & HEATING CONTRACTOR

IN THIS ISSUE

The gas welding of aluminium and its alloys is the heading under which John G. Bolton, A.M.Inst. W., contributes	5
Trade Topics—the column that keeps you in touch—has a preview look at the second HEVAC	13
This month A. L. Townsend, M.R.S.H., M.I.P., deals with soft soldering. His illustrated contribution is on page	10
Some startling points were brought to light in a national survey on the market for domestic toilet fittings. See report page	16
Questions Answered are on pages eight, twenty-nine, and thirty-one this month ..	
Trade Topics—pages 13, 27, 28, 33, 35 and 36. Tenders—pages 35 and 36.	
SPECIAL SURVEY: Sanitary ware, on page fourteen.	

INDEX TO ADVERTISERS

British Steam Specialties Ltd. .. 34	M.A.B. Insulations Ltd. 30
Boylan, M. A. Ltd. 32	Monsell Mitchell & Co. Ltd. 32
E.S.B. 9	Newman Hender & Co. Ltd. 12
Fry's Metal Foundries Ltd. 11	Paul, W. H., Ltd. 18-19
Fordham Pressings Ltd. ... Cover iv	Quadrant Engineers 1
Fyffe Couplings (Ireland) Ltd. ... Cover iii	Rowan, M. & Co. Ltd. 36
Grohe, Friedrich 25	Sanbra-Conex (Ireland), Ltd. 7
Hammond Lane Industries Ltd. ... 25	Shires & Co. (Ireland) Ltd. 4
Irish Shell and B.P. Ltd. ... Cover i	Slater, John (Stoke), Ltd. 22
Industrial Gases (I.F.S.) Ltd. 1	Stewarts & Lloyds of Ireland Ltd. ... 2
Ideal-Standard Ltd. 17	Unidare Ltd. Cover ii
Irish Equipment Co. Ltd. 20	Walker, Crowweller & Co. Ltd. 22
Kelly, Dan, & Co. 34	Wavin Pipes Ltd. 12
Leinster Engineering Co. Ltd. ... 30	Welding Services Ltd. 28

**THOSE WHO
SPECIFY IT...**



THE ARCHITECT with an eye for efficiency also sees in the Lynx's clean-cut lines contemporary styling at its very best.

**THOSE WHO
INSTALL IT...**



THE PLUMBER finds it easiest of all to fit; the concealed fixing is neat and simple.

**THOSE WHO
OWN IT...**



THE CUSTOMER is delighted to discover that such a handsome cistern also has the most discreetly quiet and dependable mechanism she's ever encountered.

...All acclaim the

Shires **LYNX**
MADE IN IRELAND

Shires Lynx is today's most popular cistern, for replacements or new installations. Lynx high and low level cisterns are made of black Duranite — tough and durable, non-crazing, non-corrosive. The Kingfisher syphon mechanism gives a powerful flush: made of polythene — non-corrosive, non-ageing and unbreakable — it can be used in hard or soft water areas. It conforms to BSS 1125 and Water Works specifications. Capacities: 2, 2½ and 3 gallons.

**EVERY GENUINE LYNX HAS THE
NAME ENGRAVED ON THE CISTERN**

Other Shires' products are the Uni-Lynx close-coupled suite, cistern fittings and the Polyfloat cold water cistern float.



made by
Shires
for your convenience

<https://arrow.tudublin.ie/bsn/vol2/iss5/1> *Shires' providers in the Republic*
DOI: 10.21427/D79T3D

SHIRES (IRELAND) LIMITED, STANAWAY DRIVE, CRUMLIN, DUBLIN

GAS WELDING ALUMINIUM AND ITS ALLOYS

TO CONTINUE our series on gas welding techniques we now consider aluminium and aluminium alloys. These have entered the plumbing and heating field in recent years, and cases often arise in the course of work where welding is involved, either for new fabrications or in repair work.

Many craftsmen in the trade look on this technique as something new, whereas, in fact, aluminium was being gas welded at the beginning of this century.

One of the difficulties in welding this metal is that it does not give warning by changing colour when approaching welding heat, and so the welder may find that it will collapse suddenly. Support of the job is therefore very important so as to prevent this happenig. Another point is that aluminium conducts heat about five times more rapidly than mild steel, so that a larger blowpipe tip is sometimes required for heavy material.

Removed

IN the welding process, the oxide which is present on all exposed aluminium surfaces must be removed. To do this a flux is used which combines chemically with the oxide to form a fusible slag. This flux is normally sold in powder form, but due to the fact that it contains lithium chloride, and so absorbs moisture rapidly from the air, it will be converted into a liquid mass with resultant poor fluxing efficiency, unless the container is kept securely sealed when not in use. How often do we see on jobs a rusted tin minus lid half filled with useless moisture-laden flux?

It is important to realise, too, that the flux is highly corrosive and all residue must be completely removed when the weld is finished. For this reason butt joints are to be preferred to lap joints where it is possible that the flux might creep into the lap and later cause corrosion. This also applies to joints on tubes where the

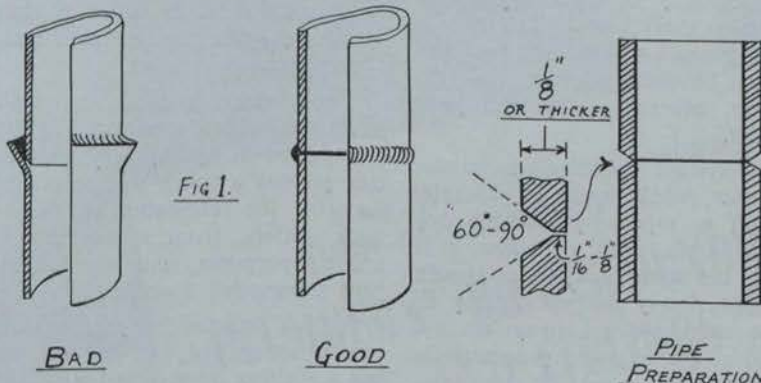

flanged cone (similar to that used on copper tube) is not, in this instance, considered as good as the plain butt or face to face joint. This latter type does not provide pockets for flux inclusion (**Fig. 1**).

In welding aluminium sheets of 22 gauge or thinner section, the usual practice is to turn up the edge of the sheets about $\frac{1}{8}$ in. and butt them together so that the flange edge is melted down and thereby acting as a filler rod at the same time.

Great care

AGAIN, great care must be taken to prevent flux inclusion in the joint.

For heavier sheets and tubes the material should be bevelled to an angle which may range from 45 to 80°, depending on thickness. Prior to welding all traces of oil or grease must be removed from the metal and the edges wire brushed to remove

oxide. Immediately this is done, the work should be fluxed.

It is most important to keep the use of flux to a minimum due to its corrosive properties. In fact, the over supply of flux is about the most common fault in aluminium welding leading to all sorts of trouble later.

Fluxing

ALTHOUGH the flux can be obtained already mixed in paste form, a flux paste can be made from the powder by mixing it with methylated spirits or water—the former having the advantage of evaporating quickly once the paste has been applied to the metal, usually by means of a small brush.

The filler rod is also coated with flux by heating the end and dipping it into the dry powder.

the
author
John G. Bolton
Lecturer in Plumbing and Heating at the College of Technology,
Bolton Street, Dublin.

*Continued
overleaf*

The Irish Plumber and Heating Contractor.

from previous page

Welding procedure

GAS welds on aluminium should be made in one run only, if at all possible, but on thick material or castings it may be necessary to do two or even more runs. But in each case all traces of flux residue and slag must be removed from the previous run, otherwise a porous joint will result.

The leftward welding technique (see March, 1962, issue) is generally used, and is especially suitable for joints in tubes and cylinders. If possible, the tube or cylinder should be rotated slowly during welding so that the weld pool is always on the top, and as the leftward procedure is used the rotation should be clockwise.

For branch joints the opening in the main pipe should be tafted up to form a lip, and the branch pipe welded to this by a plain butt joint (not flange). **Fig. 2.** For small tee joints the branch can be saddled to form a neat fit and then welded, but beware of flux inclusion.

Neutral flame

THE blowpipe flame should be neutral with perhaps a very slight trace of excess acetylene so as to avoid oxidization. The ideal is an absolutely neutral flame.

For the welding of pure aluminium, sheets or tubes, a pured raw aluminium welding rod is required, but for welding aluminium alloy castings, filler rods of similar composition should be used. A rod containing 5% Silicon will be found suitable in most jobs of this type, although certain types of cast alloys may require

a 10-12% Silicon rod. Try to check on the composition of the alloy before commencing work.

Brazing aluminium

WHERE the craftsman has not got sufficient skill, or where the aluminium sheet or tube is thin, a brazing process can be used instead of autogenous welding.

This method uses a low melting point rod, which, when applied to the joint, runs in by capillary action. It has proved a quick and economical way for the fabrication of flashings, back gutters, front aprons, etc., for roofing purposes, and has for many jobs superseded "welding."

In this process the parent aluminium is not melted, but the rod, which has a melting point about 80°C below that of the parent metal, will run, almost like fine solder, and form a neat, smooth joint with perfect penetration.

Joint preparation for this type of work differs somewhat from that previously mentioned, in that lap joints are preferable to butt. The amount of overlap should be kept as small as possible so as to ensure complete penetration of the joint. **Fig. 3.**

Desirable

THE blowpipe flame and tip size should be the same as that for aluminium welding, and a soft flame is desirable. When applying the rod a backward and forward movement in the direction of the joint is recommended.

As indicated earlier, the metal does not change colour when heated, so that the critical brazing temperature can only be found by touching the



Typical Brazed Joints

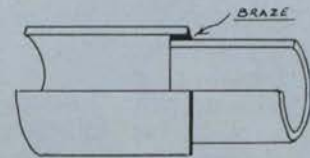
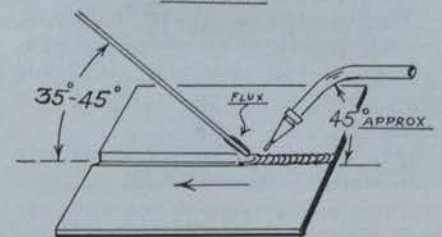

FIG 3.



ALUMINIUM BRAZING

fluxed rod to the job from time to time until the flux runs and the rod begins to melt.

When properly carried out, this process will give joints of a strength equal to that of the parent metal and due to their smooth appearance require little or no finishing off.

All traces

IT is most important, however, to remove all traces of the flux immediately the weld is finished, as it is highly corrosive—even more so than the aluminium "welding" flux. To do this, very hot water and a stiff bristle brush will be found effective for most jobs, although a weak solution—say 5%—of nitric acid may be applied to parts not easily got at. In turn, of course, this acid must be removed by washing well with running water.

If the job is small, an alternative method is to immerse it in a container and boil for about 15-20 minutes. This ensures that all traces of flux are removed.

Finally, to recap., it is important when brazing aluminium, particularly for those new to the process, to wait until the flux can be seen to flow freely before applying the filler rod. Avoid, also, too much heat, or this will render the deposit of filler metal difficult to control as it will tend to run and spread.

ALUMINIUM WELDING

Recommended Methods to avoid flux inclusions in welds

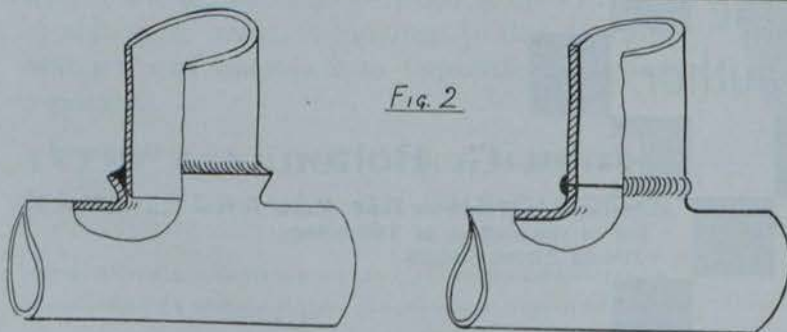

Fig. 2

Good

**CÉAD
MÍLE
FÁILTE**



... AND MAY WE OFFER TO MEET ALL
YOUR REQUIREMENTS FOR
**PLUMBERS' BRASSFOUNDRY
TAPS AND FITTINGS**



290 Trap



5301 EC. Pillarcock



5302 Bibcock



086 Lavatory Waste

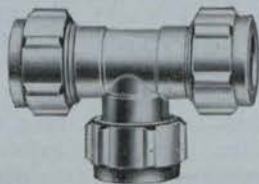

12x Tee-Piece



171x Combined Fitting



53x Stopcock



1650 Valve

The SANBRA-CONEX (IRELAND) LTD. range is designed to meet your requirements for all plumbing services in copper or plastic tubes, above and below ground. It includes Pillarcocks, Bibcocks, Wastes, Plugcocks, etc.—and CONEX Compression Joints and Fittings, Valves, Stopcocks, and Drawn Copper Traps. SANBRA-CONEX products are approved by the leading Architects, Surveyors, Plumbers, Contractors, Government Departments, Municipal Authorities and Water Works throughout Ireland. For speedy, economical, **better** plumbing, you can always depend on SANBRA-CONEX products.

★ **VERY PROMPT DELIVERIES**

★ **ATTRACTIVE PRICES**

**HOT BRASS PRESSINGS TO SPECIFICATION
POLISHING & CHROME PLATING CAPACITY**



**FREE! Write TO-DAY for your free copy of our
FULLY ILLUSTRATED CATALOGUE.**

SANBRA-CONEX (IRELAND) LIMITED, SANTRY AVENUE, SANTRY, CO. DUBLIN

Telephone: Dublin 373637. Telegrams: SANCO, DUBLIN.

Questions

Answered



"Explain purpose of sniffler valve"

Explain the purpose of the little sniffler valve on the end of a working box of a pump (usually a piston pump) and in the case of a pressure pump this is connected to the pressure cylinder.

By the term "piston" pump, the querist no doubt has in mind the single or double acting, reciprocating class of pumps. These have what are virtually pistons in place of the valved buckets found in the "lift and raise" class of pumps. Reciprocating pumps are sometimes referred to as "force" pumps and in vertical single acting form have been used in water pressure testing equipment for pipework and even as devices for forcing blockages through drain pipes, etc.

The double acting reciprocating pump, usually belt driven by some convenient motor, has long been used for raising water. By virtue of their double acting reciprocatory motion they deliver a continuous stream of water, thus obviating pressure shocks to pipework and pump as occurs in single acting ones, unless a concussion absorbing air vessel is fitted. Such pumps are still obtainable to-day, and although centrifugal pumps are now available, the small double acting reciprocating ones more than hold their own when used for open discharge deliveries.

In the writer's quite considerable experience in water pump work he has not come across sniffler valves on pumps though they are commonly fitted to

tion of the snift valve is to admit minute quantities of air on each pulsation of water as it is delivered to the air vessel, which is an integral and functional component of the ram. As water rushes up the neck connecting ram to air vessel, so, as velocity of flow increases momentarily at that point, the pressure within decreases. At this moment of time the now greater atmospheric pressure pushes a little amount of air into the fast moving water stream. The air, being 800 x lighter than water, rises to the top of the air vessel to make good that air normally dissolved into the water as it is delivered under pressure to the air vessel and thence by way of delivery pipeline to high level storage.

Function

IN THE case of the ram, the function of the air vessel is to accept the incoming water from the ram pulsation. The air capacity of the vessel is reduced by water compression of it and as soon as the related ram pulsation is over and the non-return valve at the vessel inlet closes, the compressed air re-asserts itself by pressing the trapped air vessel water content on up the delivery pipe.

In the case of pumps, an air vessel has been commonly recommended for single acting pumps so that the compressive property of air may be utilised as a shock absorber, and to reduce pumping effort whether it be manual or machine operated. Clearly, on the upstroke of such a pump, the water is moving along and up the delivery. It gains a certain

momentum which, if uninterrupted will continue in the same direction whilst the downstroke preceding the next upstroke is made.

This eases pumping effort since the water is already in motion, in the right direction. It prevents shock on the pump and pipework by avoiding the inevitable "fall back" of delivery water with a terrific bang on the top pump valve at the end of each up stroke and beginning of the next downstroke.

In pumpwork of this kind the air vessel situated close to the pump at its delivery outlet, acts as a shock absorber and as a means of maintaining water propulsion along the delivery pipe in much the same way as described for the hydraulic ram. A snift valve, which is a kind of non-return valve to let air in but to stop water leaking out, could conceivably be fitted to such an air vessel and at a point between it and the pump. It might then serve just as it does for the ram. However, since pumps of this kind for domestic pumping usually are situated in a kitchen and close by a sink, it was customary to take a tap off the delivery pipe just below the air vessel. Before starting to pump one opened this tap, drained the pipeline and air vessel of water so as to fill both with air, and then on starting to pump a fresh air supply was trapped in the vessel.

For larger reciprocating pump sets where air vessels are used, provision is made in the pump casting for fixing of a snift valve, and the use of these for this work seems to be more common than hitherto.

For automatic pump sets working on the principle of passing water to an enclosed store vessel, thereby compressing the air content which then forces the water out of opened taps, a snift valve is applicable to the pump delivery outlet for the same air replenishing reasons are outlined above.

Continued page twenty-nine

Each month this column will solve some of the everyday problems of the plumbing and heating engineer when our consultants deal with queries directed to "Questions Answered." All queries will be replied to and the most interesting published.

DON'T RISK MEN'S LIVES

In the interests of public safety, the E.S.B. has statutory authority to prohibit the erection of buildings and structures within twenty-five yards on either side of the E.S.B. lines. Should such building be necessary, the Board should be given, in writing, two months notice of such intention in order that the feasibility of such building may be investigated.

The Board has also issued repeated warnings to farmers and other operators of special equipment to exercise care in the use of high machinery near E.S.B. lines.

The ignoring of such regulations and warnings has caused a number of accidents, and in the last five years six of these accidents were fatal.

When work becomes necessary adjacent to E.S.B. lines, local E.S.B. staff will, in the interests of public safety, make arrangements so that the work can be done in safety.

PROTECT LIFE

STAY CLEAR OF ELECTRIC POWER LINES

Soft Soldering

COPPER bit soldering has already been mentioned as a jointing method for some zinc weathering details. Nowadays copper tube joints are generally made with solder capillary fittings, where the solder is melted in a blowlamp flame, and runs into the joint. Copper bit soldering tends to be neglected and this is a pity, for properly used it is a skill that can still be put to very good use.

What is soldering? Very briefly, it may be described as the joining of two metals by another, the solder, which has a lower melting temperature than either of the others. This is so because the two metals to be joined are not meant to melt and fuse, as happens in welding. In soft soldering, as copper bit work is called, the solder melts, flows between, and actually combines with the surfaces of the metals to be joined.

You will remember that when oxygen comes in contact with metals it reacts with the metal to form an oxide, which is non-metallic.

You may have noticed that cleaned copper tube changes colour when it is heated. This change is caused by the rapid combination of atmospheric oxygen with the hot metal, which forms a non-metallic skin of copper oxide. This is a chemical change.

Cleaned

METALS can be soldered but non-metals cannot, so that before soldering or welding is begun the area to be treated must be cleaned free of the oxide. With lead or iron, heat will be enough to melt away the oxide, revealing the pure metal underneath. The oxide will float on the surface of the molten weld pool, so that if correct methods are used these metals can be cleaned and welded quite easily.

The oxides of aluminium have a higher melting point than the metallic aluminium underneath, so that it is rather more difficult to weld this metal. However, by enveloping the electric arc in a "shield" of inert

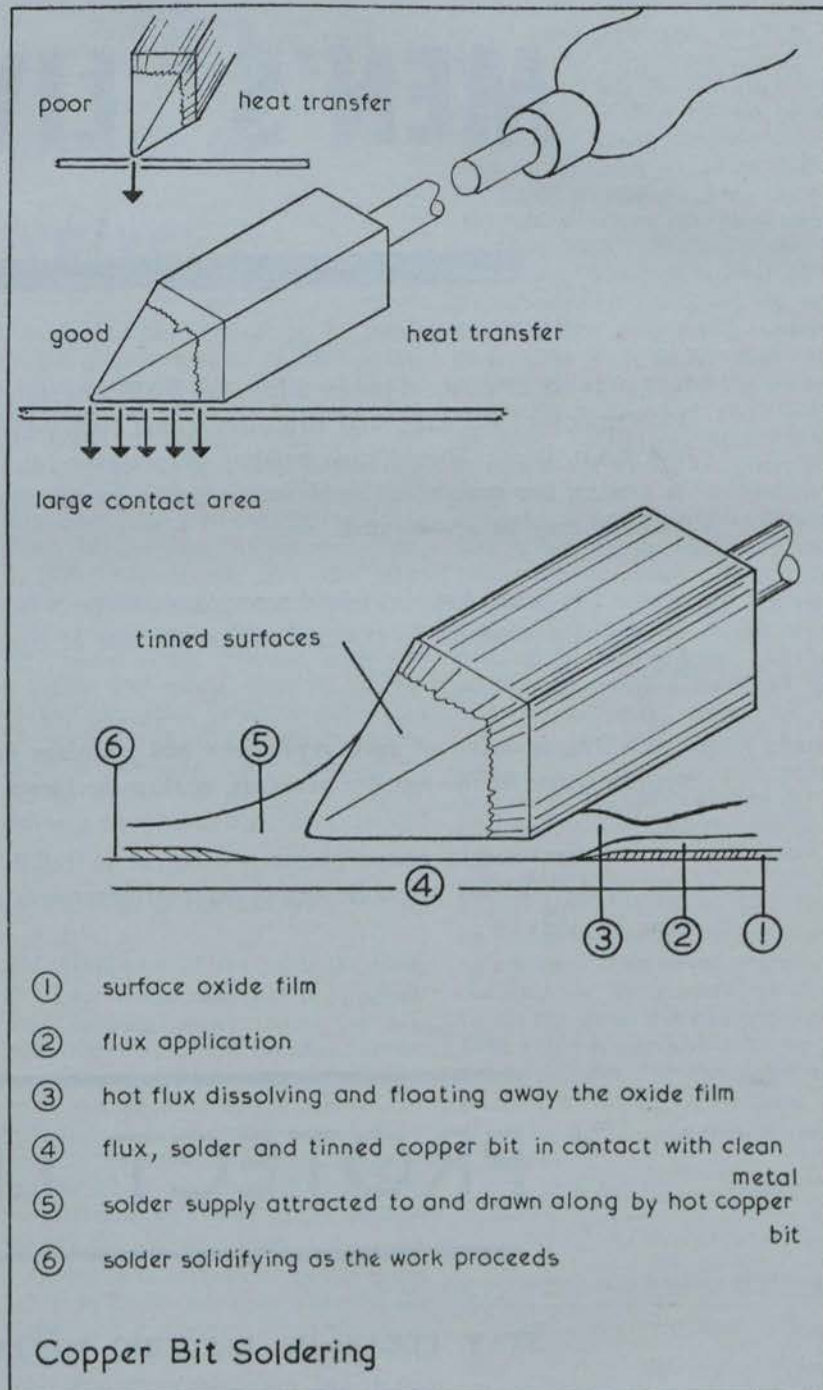

Continued on opposite page

gas—argon—the oxygen can be kept away from the metal and the weld made. This is called the argon-arc process.

A similar method is adopted for the welding of plastic materials such as polythene and P.V.C., both of which will readily oxidise when heated. In this case nitrogen is used. The gas, at a pressure of two to three pounds per square inch, is heated in special torches to about 300 C, at which temperature it will melt and fuse the plastic surfaces.

Not enough

WITH copper, however, heat by itself is not enough to remove the oxide, and special reducing agents, called fluxes, are needed. When applied together with heat, these will bring about a local reduction of the oxide, and float it away to reveal the true metal underneath. Since heat encourages oxidation, it is also important that the flux prevents the oxygen in the atmosphere from coming in contact with the metal surface. Moreover, it helps the solder to flow over surfaces, so that it "wets" or tins them easily.

Before one begins to solder copper, it is necessary to clean the surface by mechanical abrasion. "Abrasion" means scraping, and a file, wire brush or sandpaper are used for the purpose.

Adequate heat is essential if the solder is to penetrate the metal surfaces properly. Obviously, the heat must be great enough not only to melt the solder but also to raise the temperature of the metals being joined so that they will readily accept the "wetting" or tinning action of the solder, and allow it to form a combination, or bond, with them.

Transfer

THE COPPER BIT, or soldering iron, is a wooden handled iron shaft with a copper "bit" on the end. Copper is used because of its high heat conductivity which allows it to transfer its heat quickly to the soldered joint. It also heats up very rapidly. Its capacity for heat, that is, the amount of heat it can transfer to the joint in a certain time, depends upon the size of the "bit."

Copper "bits" are sized according to the weight of the copper used, and, generally, the bigger the copper bit



A. L. TOWNSEND
M.R.P., M.R.S.H.

The author, a lecturer at Oxford College of Technology, continues the first part of a four stage course on plumbing.

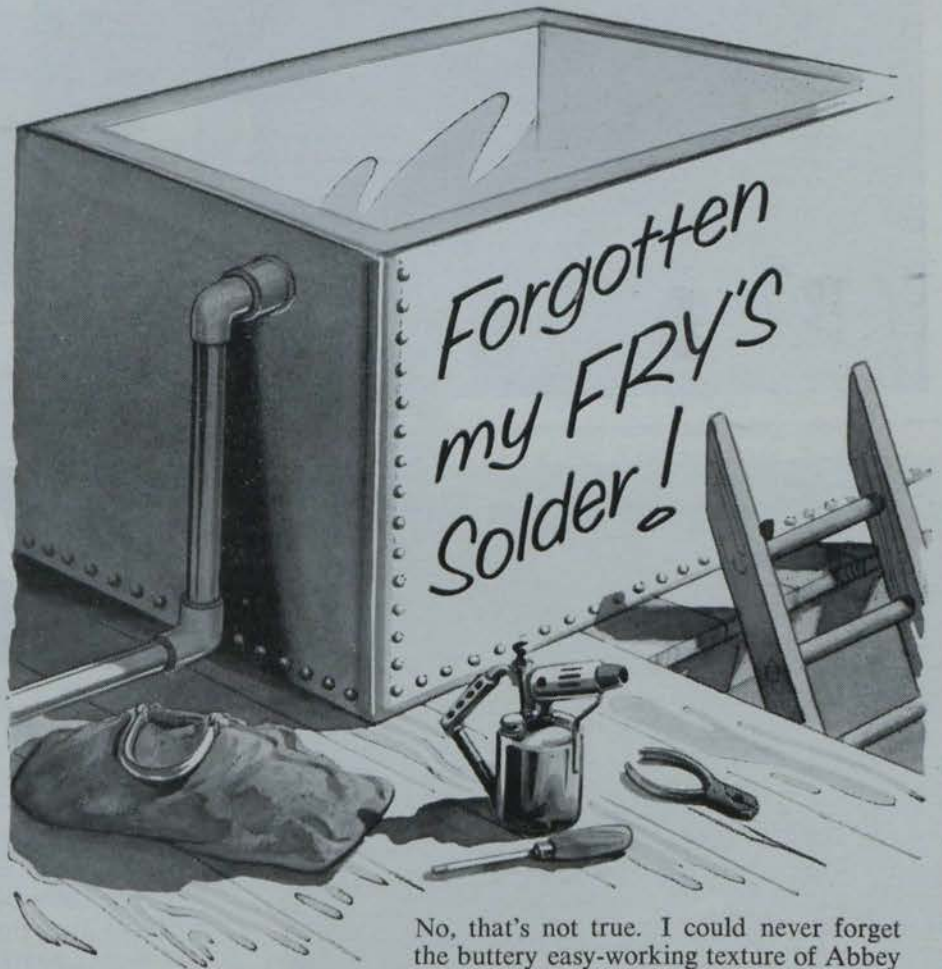

No, that's not true. I could never forget the buttery easy-working texture of Abbey and Belfry . . . or the way they cool, dead smooth without a crack or blemish.

No, I've not *forgotten* my Fry's plumbers metals—I've just left them behind!

Better phone up . . .

FRY'S Metal Foundries Limited

197 Pearse Street, Dublin. Telephone: DUBLIN 74243

And at: LONDON - MANCHESTER - KIDDERMINSTER - GLASGOW

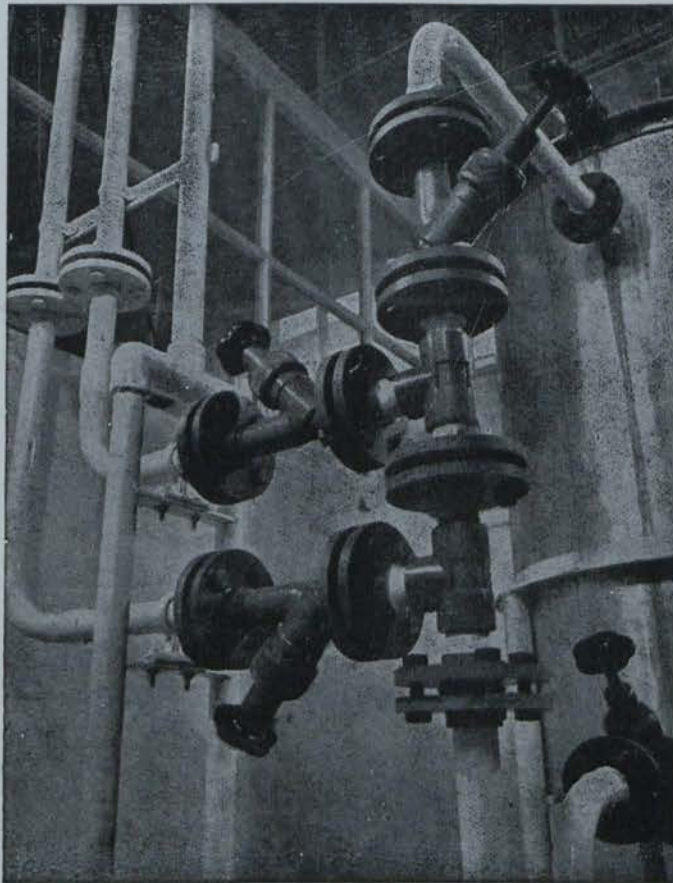

We chose Wavin PVC...

AT CASTLEFORBES WORKS

Castleforbes Works had a problem! A highly corrosive chemical, used in their modern manufacturing process in Dublin made very short work of conventional pipes. This could mean frequent renewal of the pipe-lines, with consequent loss of production and the risk of dangerous bursts—but they chose Wavin PVC because Wavin PVC Pipes are immune to chemical attack. They are also inexpensive and easy to instal, with a complete range of PVC fittings. And they solved their problem efficiently and cheaply.

If you have a problem in pipework, why not consult Wavin—the pioneers of PVC in Ireland.

wavin

WAVIN PIPES LIMITED
 CIAN PARK, DRUMCONDRRA, DUBLIN 9
 Telephone : 48000 or 373614/6



NEWMAN HENDER VALVES AND FITTINGS

Known throughout the world for the dependability and quality of their wide range of valves and fittings you cannot do better than ask Newman Hender *first* for the valve or fitting you require. Stocks are held in Dublin of many patterns to meet constant and urgent demands.

VALVES ARE OUR BUSINESS

... in most types and sizes
 ... for most temperatures and pressures
 ... for most industries all over the world.



NEWMAN HENDER & CO. LTD.

WOODCHESTER · STROUD · GLOS. · ENGLAND

AGENTS & STOCKISTS

C. H. LOCKHART LIMITED

75, MIDDLE ABBEY STREET, DUBLIN Phone: DUBLIN 43487

TRADE

TOPICS

Dublin plumbing courses re-open

The Day Release Courses in plumbing held in the College of Technology, Bolton St., Dublin, will re-open for enrolment during the week commencing Sept. 3.

These courses involve attendance for one day per week—9 a.m. to 5 p.m.—during the session from September to June. Many employers in the industry co-operate in this scheme by allowing their apprentices to attend without loss of pay and, in fact, some students travel from as far as Navan to avail of the facilities offered.

The fee for the full session of approximately 40 weeks is £2-10-0 and classes are held for 1st, 2nd, 3rd, 4th and 5th year students.

Early application to the College is essential as accommodation is limited.

DRAWING SERVICE

International Boilers and Radiators Ltd., Earlsway, Team Valley, Gateshead, advise that their drawing service is available to Contractor readers covering small bore heating layouts. Fees are to the following scale:

0-40,000 B.T.U.'s hour — 5 gns.;
 40,000-50,000 B.T.U.'s hour—6 gns.;
 50,000-60,000 B.T.U.'s hour—7 gns.;
 60,000-90,000 B.T.U.'s hour—8 gns.;
 90,000-120,000 B.T.U.'s hour—9 gns.;
 120,000-150,000 B.T.U.'s hour—10 gns.

Over 150,000 B.T.U.'s hour to be charged on the amount of work necessary (estimates will be provided on request).

NEXT MONTH

John G. Bolton says—

In our next article, which will conclude the present series on welding, we will deal with some aspects of the welding and brazing of stainless steel, die cast zinc, etc.—materials which have in recent years entered more and more into the industry.



AT OPENING OF NEW WAVIN BALBRIGGAN FACTORY



Last month we reported the opening of the new Wavin factory at Balbriggan when these photographs were taken.

Top: Mr. Thomas McMahon, chairman and managing director with the Taoiseach, Mr. Lemass; Mr. J. C. Keller, director; the Lord Mayor of Dublin and the Mayor of Drogheda.

Left: The Taoiseach inspecting the new factory with Mr. McMahon.

SECOND HEVAC: NEW TECHNIQUES ON SHOW

AT the second International Heating, Ventilating and Air Conditioning Exhibition (HEVAC) at Olympia from September 26 to October 5, new techniques that mean a saving in fuel and basic capital cost of installation will be shown for the first time.

The industry in Britain now has a turnover of more than £50,000,000 a year, with exports running at some £5,000,000. Initially, many of the engineering ideas in heating and ventilating came from America and Canada, where the more sophisticated systems have been operating for years. British engineers, however, have not been content merely to copy these systems:

there have been quite dramatic technical developments, many of them initiated in the research departments of British manufacturers.

Many of these new developments will be shown for the first time at the HEVAC exhibition at Olympia next month. Particularly advanced are new automatic control systems. These have been designed not only to maintain an equable temperature, but can be "programmed" to carry out a sequence of events, completely closing down for predetermined periods, yet starting up in time to warm thoroughly

continued page thirty-three



SANITARY WARE

GREAT CONTRIBUTION TO OUR LIVING STANDARDS

'Cleanliness is next to Godliness.'

PHILOSOPHERS might question the truth of this old adage but we all know and appreciate the sense of physical well-being that a leisurely taken, relaxing hot bath provides. Similarly, those of us who cannot spend as much time as we would like in warm, pleasantly decorated, well-equipped modern bathrooms, enjoy physical and moral benefit from a quick nip into it and out of the shower bath. Some like the water hot, some like it cold. Adequate water supplies, both hot and cold, and mixer taps, thermostatically controlled for showers, perhaps, enable personal choices to be met to a fine degree.

Personal cleanliness was a cult akin to a religion with the early Romans. So important a feature of their existence was the bath that these were of the communal type designed for comfortable lounging and conducive to discussion among the bathers. No longer do we hold discussions in our bathrooms of to-day. For some, the bathroom becomes the operatic stage. For all, a place of relaxation, contemplation, and relief.

In the Middle Ages, personal cleanliness was so little thought of that expectation of life, even in peaceful times, was sadly foreshortened by disease. The Order of the Bath was instituted as a ritual accompaniment to this elevation to knighthood by one English monarch who, no doubt, felt disinclined to mention B.O. to his best friends.

Bathed once a month

LATER we learn of noblemen having bathing facilities installed and that they "partook of baths once a month whether they needed it or no." In the early 18th century street vendors in London cried "Hot water and baths." These offered portable hip baths on loan and a few jugs of hot water from their steaming, cart mounted, coudrons.

The contribution made by modern bathroom and toilet facilities to improved living standards cannot be over emphasised. Quick to sense this enlightened trend in public demand for more spacious, comfortable, and properly equipped sanitary facilities,

the architect is glad to conform and so the bathroom becomes a major feature recognised as of important social and hygienic value and essential to the full enjoyment of what other good living features the house might possess.

Sanitary ware design and manufacture has not lagged in this trend. Indeed, it might well be said that improved design of appliances has caught the public eye and thus the public demand for higher standards of toilet facility in house design has stimulated an all round improvement in bathroom function, design and usage.

Clearly, in lower cost housing, the space available is restricted. But even so a little care at the planning stage will afford ample space to accommodate a bathroom suite of pleasing modern design.

For conversion work to quite small cottage, the "Bink" combined sink and bath unit offers a practical and effective solution to the lack of space problem. These units are obtainable with integral 30-gal. D.H.W. store and heater from Bink Development Ltd.

continued opposite



This special survey—another in a series on important aspects of the plumbing and heating trades—has been compiled by technical expert A. L. Townsend, M.R.S.H., M.I.P.R.P.

SANITARY WARE

From previous page

WARMTH IN BATHROOM ESSENTIAL

WARMTH, so essential in the bathroom, can be provided quite simply by properly fitted and safeguarded electric heating appliances. These can be cheaply operated since they may be in use only for the duration of the bathroom use.

In larger houses the trend is toward really luxurious bathrooms. These will contain not only the conventional bath, basin and W.C. but will probably have shower bath fitment as well. This may be installed as a separate fitting, it may be in the form of a bath equipped with combination taps with shower attachment and shower curtains or glazed shower screen, or it may be in the form of one of the new shower cabinets which are so useful if one wishes to add shower facilities to an existing bathroom.

Heated towel rails are no longer regarded as decorative adornments but as practical, essential, functional items of bathroom equipment. In many cases these will be heated from the central heating system or, where water characteristics permit, from the D.H.W. system, when they will function even when the heating system is not in use. The towel rail would be supplemented by sufficient space heating equipment to ensure a comfortable undress temperature.

Bidets too become increasingly found in modern bathroom design and usage. These appliances are strictly ablation appliances. Their main function is to afford washing facilities for the excretory organs.

An effective cleansing function

A MOMENT'S reflection will clearly show how much more effective a cleansing function is achieved by the bidet than by use of toilet tissue. Its particular value to female members of the household must not be overlooked. The appliance can also serve as a footbath if necessary.

A bidet might cost from £20 up. This may be regarded as an expensive alternative to the toilet roll and toilet roll holder. The really discerning client will be quick to appreciate the comfort and hygiene advantages of the bidet if these are wisely put.

Bidets, you will note, are fitted with a submerged inlet. As such these appliances are subject to specific by-law prescriptions as to method of water service connections. An intending installer would do well to be aware of these requirements, aimed to avoid pollution of other services.

Wastes of the pop-up kind are used on bidets and connect to a trapped 1½ in. waste pipe. As the appliance is classified as a "waste" appliance it can discharge to a main waste stack accepting bath, basin and sink wastes. If so fitted, it should enter the M.W.P. by means of a junction and never over an open hopper head. Hopper heads are insanitary arrangements anyway and their eventual banishment for waste water collection will not be mourned. Bidets may discharge direct to soil pipe subject to trap retention precautions being taken according to whether one pipe or single stack systems are being used.

The bidet is virtually an accessory to the W.C. pan and should therefore be fitted alongside it. Space and cost

This article is continued on page twenty.

National Survey

Overleaf we report, in conjunction with this special survey, the informative and important findings of a national survey on the market for domestic toilet fittings.

prohibit bidet provision at all W.C.'s but there can be no doubt that it fast becomes an item of informed choice.

Remarkable artistic styles

BATHS vary only in the remarkably artistic styles and colours which manufacturers consistently strive to improve upon. Materials now include the well tried cast iron, the more recent pressed steel baths, and the even more recent plastic baths of "Per-spex." A few enquiries of advertisers in this Journal will bring you literature from which you can glean the advantages of each material and cost comparisons can be made. It is true to state that the cast iron bath is still the most used, but the lighter pressed steel baths are becoming more used and in time the plastic baths might well prove to be a serious rival to both.

Combination tap sets for baths, with or without handspray attachments, enhance the appearance of any bath and bathroom. The handspray offers convenient hair-washing facilities and a means of clean sluice after total immersion bathing. It can be adapted to provide full shower bath facilities too. These fittings are well worth serious consideration when planning bathroom installations.

Hand grips for baths may seem a pointless extra to the active bather. For the very young, the old, and the infirm, a wisely placed hand grip makes the getting in and out of a bath a safer and therefore more pleasing effort. Most manufacturers are wisely incorporating alternative hand rail designs at small extra cost.

Toe space at the bottom of the bath panel enclosures are another feature of bath design which has received manufacturers' attention. For those who have to lean over a bath to attend youngsters or old folk, these toe spaces are a boon.

The Irish Plumber and Heating Contractor.

A national survey carried out for the Council of British Sanitary Pottery Manufacturers Ltd. on the market for domestic toilet fittings in Great Britain, has revealed that 65 per cent of the public refer to the lavatory as "the

toilet", while 4 per cent call it the W.C."

Two per cent have their own pet titles, with 15 per cent using the term "lavatory" and 14 per cent the "Bathroom".

ONE PER CENT SAID THEY WERE WITHOUT A W.C.

THESE findings are the result of interviews carried out with housewives who are living in a house or flat which is owned by their husband, or which they are in the process of buying. Houses or flats which are rented were excluded from the survey.

The survey shows that virtually all these privately owned houses have a W.C., regardless of class or age or owner, or age of houses, but 1 per cent said they were without a W.C. A proportion of 22 per cent was found to have an outdoor W.C. only and this occurred mainly in lower-class houses, and houses 50 or more years old.

With regard to washing facilities, it was found that 21 per cent of houses had no washbasin, and that 18 per cent were without a bathroom. Seventeen per cent were without a bath, and they were all living in houses more than 50 years old, but 45 per

cent of houses owned or being bought were 50 years old or more.

Most people felt it worthwhile to spend a fair amount of money on bathroom fittings. They remarked that most W.C. tanks were noisy in refilling, and that a coloured washbasin and bath were more attractive. A higher proportion of upper-class people remarked on the importance of a downstairs cloakroom and wash-basin in the bedroom.

The ideal W.C. is described as "low" by 64 per cent, and "coloured" by 19 per cent—largely by younger age groups. Only 9 per cent have, in fact, a coloured W.C. The ideal washbasin was voted to be the "pedestal" style by 49 per cent of the informants, "coloured" by 25 per cent, "large" by 25 per cent.

Thirty-six per cent said they would

like one or more additional toilet fittings in their home. This included 17 per cent who wanted a W.C., 12 per cent a washbasin, 8 per cent a complete bathroom and 4 per cent a bath and 4 per cent a shower. The lower-class groups, and particularly people living in houses 50 years old or more wanted a complete bathroom comprising both a basin and W.C.

Asked to list six items of sanitary ware in order of preference of choice of amenities, 72 per cent plumped for "a coloured suite in the toilet", closely followed by a "downstairs cloakroom with "W.C." with a 67 per cent poll.

Shown a photograph of a bidet (pronounced "beeday"—French word meaning "little horse"), only 14 per cent were able to make a correct identification, while 65 per cent admitted that they had, in fact, not seen such a fitting before.

Glazed pottery (described by many as porcelain) was widely known and thought best as the material for W.C.'s and washbasins, the main reasons for preference being its reported ease of cleaning and durability. Two thirds had no idea of the purchase price of a new washbasin or W.C., and three-quarters were unable to give any estimation of installation costs.



We picture here the "Lynton" basin and pedestal by Doulton Sanitary Potteries Ltd. The "Lynton" is one of a number of forthcoming designs.

ware and sizes are 25 x 19" and 27 x 22".

Forthcoming designs also include No. V3105 Unidart W.C. Suite and the No. V3000 new Victor W.C. Suite.

Irish agent is: Mr. S. M. Jones, 47 Wellington Quay, Dublin.

★ ★ ★

From the Ideal Standard Ltd. range we feature here:

"Princess" luxury wash basin and dressing table available in the five "Standard" colours and white and subtle two colour combination (Top, right).

The "Kingston" siphonic close coupled closet suite is available in the five "Standard" colours and white, also as a wash down type (Bottom, right).

Irish agent: E. J. Cocker, Stonegate, Granville Rd., Blackrock, Co. Dublin.



"Rayrad" the unobtrusive "IDEAL"

Model No. 35 in the 'Rayrad' range.
This cut-away view shows
the flat surface as well as the
cast-iron sections behind it.



Radiant warmth . . . tailor-made to any installation . . . easily fitted into *any* new building . . . so inconspicuous it can form part of walls or ceilings. That's "Rayrad", one of the most versatile heating systems ever designed. IDEAL "Rayrad" throws out a uniform, draught-free, *radiant* warmth, distributed from the whole of the radiator's flat unobtrusive steel surface. IDEAL "Rayrad" gives no *waste* heat at all. IDEAL "Rayrad"—produced in five models of varying size and design—today's ideal radiator for efficient, adaptable, uniform warmth.

"Ideal Rayrad" cast-iron proof that IDEAL lead in radiators

For full details of the "Rayrad" and other IDEAL cast-iron radiators, please write to: Ideal-Standard Limited, Ideal House, Great Marlborough Street, London W1. Telephone GERRARD 8588.

IDEAL-Standard LIMITED BRITAIN'S LEADING MANUFACTURERS OF DOMESTIC HEATING EQUIPMENT



"IDEAL" AND "RAYRAD" ARE TRADE MARKS OF IDEAL-STANDARD LIMITED

PAULOMATIC PRESSED STEEL PANEL RADIATORS



are jig-welded
to eliminate lateral distortion
combine durability
with elegant simplicity of design

Especially suitable for closed circuit systems of home heating, PAULOMATIC Radiators are pressed from high quality zinc-coated steel—to provide a rust-free surface and are jig-welded—for freedom from lateral distortion. Each PAULOMATIC Radiator is safety tested under water at an air pressure of 40 lbs. per sq. in., and before leaving our factory is given a coat of non-metallic primer for subsequent painting to suit individual colour schemes. To meet special requirements we can stove-enamel in various colours at an extra cost of 1/6 per sq. ft. PAULOMATIC Radiators are available in straight panels in standard heights of 15", 18", 24" and 30" and lengths from 15" to 92½". Longer sections can be supplied to order. To meet customers' specifications, PAULOMATIC Radiators can also be supplied to order, in curved, angled and double or triple banked sections. Radiator covers, prime coated or stove-enamelled (complete with sealing strip) are available—also adjustable brackets for top, side and bottom.

<https://arrow.tudublin.ie/bsn/vol2/iss5/1>

DOI: 10.21427/D79T3D

Eighteen

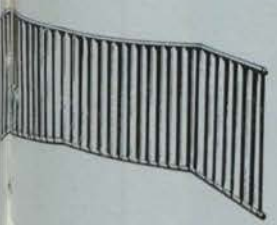
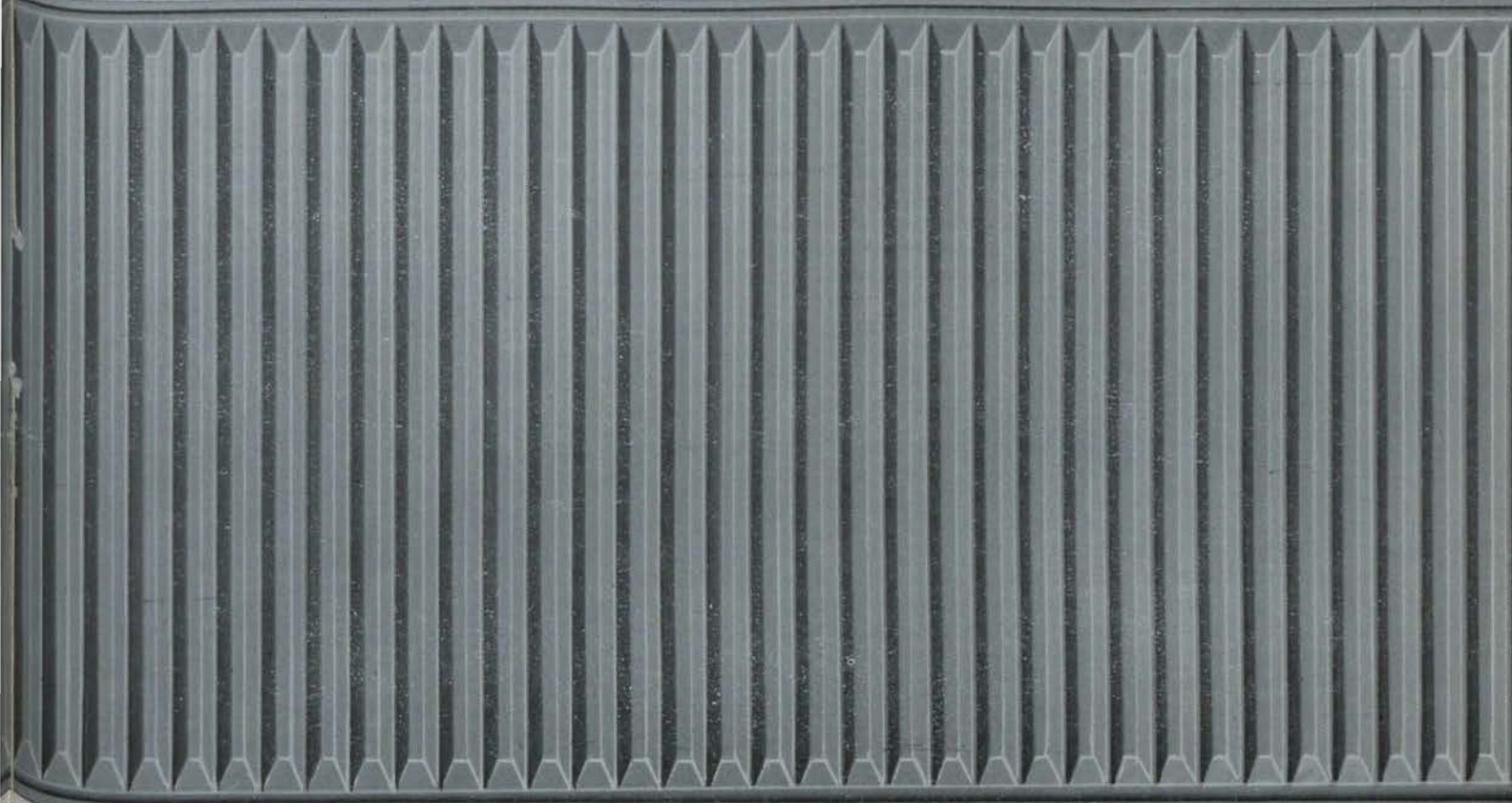

PHLOMATIC Radiators can be made to order to meet any specification. The angled window bay



or double or triple banked to give maximum heat where space is at a premium.



If your heating problem is a lighthouse or only a simple semi-circular bay window, the curved model is the answer.

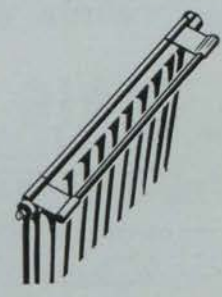

The Paul towel-rail is simple to fit and is functional without being unsightly.



Stocks held by our agents:

G. F. MORLEY LIMITED
45, QUINN'S LANE, FITZWILLIAM SQ., DUBLIN.
Telephone 66949.

W. H. PAUL LTD. · BREASTON · DERBY · TEL. DRAYCOTT 581/2/3

London Showroom: 7 Royal Arcade, Old Bond Street, London, W.1. Tel. GRO3394.

Published by ARROW@TU Dublin, 1962

The Irish Plumber and Heating Contractor.

SPECIAL SURVEY—From page sixteen

Bewildering sanitary ware showroom displays

LAVATORY basins are now available in so wide a range that one is bewildered by the huge displays in sanitary ware showrooms. Designs tend to err a little on the aesthetic, one might suggest if in critical mood, and away from the strictly functional design of the well tried, skirted basin to B.S. 1188.

Materials for L.B.'s include pressed steel, plastics, and, of course, the well-tried ceramic wares. Likewise for sinks in kitchen use. Pressed steel sinks in vitreous enamel, or the more expensive stainless steels, and now the glass fibre and perspex fittings are popular in sink unit form for modern matched equipment in kitchens. Pressed steel L.B.'s and plastic L.B.'s are available, but the ceramic L.B. more than holds its own.

W.C. pans are still invariably in ceramic ware. There is little change in basic design but the rimless ap-

pliances now available show that design, thought and skill is not withheld from this more humble but perhaps more used piece of sanitary ware. Two trap siphonic pans are more used these days where the luxury of silent and positive pan content evacuation is required. These cost a little more than siphonic pans of other design but are well worth the extra cost.

Aerosol infection dissemination through the flushing of W.C.'s has recently received prominence and medical opinion backing. It would appear that it has taken those now so concerned with this aspect of domestic hygiene a long time to get round to thinking about it.

Lessened

COMBINATION or close coupled W.C. suites bring the flushing

action and water agitation lessened. As integrated appliances these are virtually free standing and no wall fixing is needed for the cistern. This relieves bathroom planning to some extent and the appliance undoubtedly looks more pleasing than the older high level arrangements or the "in between" low level arrangements.

Bathroom ventilation is worth careful attention if condensation and possible aerial nuisance is to be avoided. For bathrooms sited on external walls natural ventilation suffices, but with the trend in blocks of flats toward centrally ducted services and internally placed bathrooms, then mechanical ventilation generally needs consideration. So far as ventilating equipment is concerned, readers will find the Directory of Manufacturers, as published in the June issue of the Contractor, a helpful guide to suppliers.

Inviting bathrooms, and pleasing and equally inviting kitchens, now capture the public fancy. From the social and public health points of view this is a desirable trend.

Eliminate Noise

IN THE W.C. CISTERN AND ATTIC TANK BY FITTING A

CRAIG SILENT BALLCOCK

The **CRAIG SILENT BALLCOCK**—an outstanding invention—is completely silent in operation, it does not intrude when illness requires quiet, and guests no longer experience that disturbing sense of embarrassment created by old-fashioned noisy cisterns.

Ask **NOW** about the **CRAIG SILENT BALLCOCK**, it is simple and quick to instal, it fits any make of cistern. In this modern age of excessive noise the "**CRAIG**" performs a "New Silent Service".

Approved by B.W.A.
and leading water
authorities.

Trade enquiries to:—

IRISH EQUIPMENT COMPANY LTD.,
BALLYMOUNT RD., WALKINSTOWN,
DUBLIN.

Phone 501548.



SANITARY WARE

From previous page

● In conjunction with this special survey we review here new products from the leading manufacturers' ranges.

FROM THE range of Armitage Ware Ltd. comes this "Salonex" hair-dresser's basin, with comfortable back-shampooing feature and also suitable for front wash.



Made in vitreous china it is complete with a "Nuastyle" $\frac{1}{2}$ " mixer fitting, with flexible tube, nylon hand spray and metal sleeve; inlets screwed $\frac{1}{2}$ " B.S. male; $1\frac{1}{4}$ " strainer waste, with loose lifting-out grid; $1\frac{1}{4}$ " bottle trap, with 457 extension to wall, and wall flange; brackets in iron and toggle bolts. The fittings are chromium plated.



Also available from the Armitage range is this "Wessdale" pedestal basin in vitreous china, which includes a "Nuastyle" Nu-flo $\frac{1}{2}$ " mixer fitting and $1\frac{1}{4}$ " pop-up waste, with $1\frac{1}{4}$ " 'P' trap to wall. Fittings are chromium plated and concealed hangers are in painted

● THE CRAIG "Silent" Ball-valve, available for installation in W.C. cisterns and storage tanks, controls and silences the water supply to cisterns and tanks and is available from leading stockists. Information and pamphlets may be obtained from the manufacturers, The Silent Ballcock Co. Ltd., The Monifieth Foundry, Monifieth, Dundee, Scotland.

ONE OF Shires most popular products is their proved 'Lynx' cistern which is available for both low and high level installations. Tough and durable, the 'Lynx' is completely rust proof and impervious to corrosion.

The "Lynx" is quietly and unfailingly efficient and is fitted with non-corroding Shires Polythene 'Kingfisher' syphon mechanism which ensures a positive action flush first time and refills quickly, quietly and unobtrusively.



The new Shires Lynx Automatic Cistern illustrated here is now available in resin bonded rubber. It is specially suitable for outside installations which are exposed to the weather. From Shires (Ireland) Ltd., Stannaway Drive, Crumlin, Dublin.

Another well-known Shires product is the 'Uni-Lynx'—claimed to be the world's first close-coupled suite to combine a plastic cistern with a pottery wash-down pan. A sanitary ware unit of advanced design, it incorporates Shires 'Hydromatic' action. The wash-down pan is supplied with trap to BSS1213 dimensions to eliminate the risk of blockage. The 'Uni-Lynx' has been designed as a free-standing unit.

★ ★ ★
SHANKS HAVE produced many new lines since our last publication on this subject. Of chief interest is the Sannox Fountain (illustrated). This incorporates a new and novel principal which ensures the same height of non splashing jet at any water pressure between 10 and 100 lbs. without adjustment.



It will also be noted that part from the operating handle, jet nozzle and flush waste grating, all other fittings including supporting bracket are concealed.

A shield can be provided for jet as a small extra, this latter being essential when fountain is fitted where Dublin Corporation regulations apply.



Most readers will know of the high quality Sheerline Fittings made by Shanks and illustrated here is their new 61/38 Sheerline Combined Supply Fitting and Handspray.

Another addition is the Orwood Shelf Basin in Vitreous China. Here Shanks have retained the name of an earlier Basin of the same type, but the new Basin bears little resemblance to

Continued page twenty-three



This is our latest shower valve, the Leonard 72, available for both exposed and concealed pipework. Larger Leonard valves are, of course, available for multi-point uses such as batteries of showers, ranges of basins and troughs, washbasins, etc. Manufacturers—Walker Crossweller & Company Limited, Cheltenham.

**MODERN PLANT LTD.
CRUMLIN RD., DUBLIN**



SANITARY WARE IN WHITE AND COLOUR

(Colours to match Irish Foundries Ltd.)

Agent:

**C. B. SHERIDAN
10 HERBERT PLACE
DUBLIN.**

'Phone 66283.

Illustrating

“THE WALDORF SUITE”

JOHNSON AND SLATER

(VITREOUS CHINA)

(SANITARY FIRECLAY)

ALFRED JOHNSON & SON LTD.,
MIDDESBOROUGH, KENT.

JOHN SLATER (STOKE) LTD.,
BERRY HILL, STOKE-ON-TRENT.

its predecessor and it will be noted there are no corners under shelf where dirt can accumulate—the unit being designed to be attractive and easily cleaned.

Details and literature can be had from Shanks' representatives: C. H. Lockhart Ltd., 75 Middle Abbey St., Dublin.

★ ★ ★

THE "MAID" stainless steel sinks are produced by the Hammond Lane Foundry of Dublin who are the only manufacturers of this type of sink in Ireland. Their prices and quality are quite competitive with the imported articles. The following are the principal sizes on sale at present: 42" x 18" reversible; 42" x 18" with tap holes and handed; 42" x 21" ditto; 54" x 21" ditto and double drainers; and 63" x 21" ditto and double drainers.

Hammond Lane will shortly have on the market a 36" x 18" with tap holes and handed and a 63" x 21" with fluted drainers or flat table tops as alternative. They are now also in a position to fabricate many types of stainless steel sinks according to the users specifications.

In addition to the ever increasing sales in the Republic of Ireland an export trade is being steadily developed to Britain and the North of Ireland.

★ ★ ★

THIS PRESSED stainless steel sink top with two tap holes is from the range of W. H. Paul Ltd., Breaston, Derby. It features a high back with tiling return, seamless bowls with outlet to take a waste disposal unit, or is supplied with either a crumb strainer waste, no overflow or with a 1½" C.P. waste with plug, chain, stay, with or without overflow.



Right or left hand drainers are available and the sizes are, model 336P, overall, 42" x 21", with a bowl size of 19" x 15" x 7½" and model 130P with an overall size of 36" x 18" and bowl size of 16" x 12" x 7".

Also from the range of W. H. Paul Ltd., Breaston, Derby, is this pressed stainless steel sink top with double

SANITARY WARE

from page twenty-one



drainer and one bowl supplied with two tap holes. A high back tiling return is featured, and there is a seamless bowl with an outlet to take a waste disposal unit or supplied with either a crumb strainer waste, no overflow, or with a 1½" C.P. waste with plug, chain stay, with or without overflow. The available size is—overall, 63" x 21" and bowl size, 19" x 15" x 7½".

★ ★ ★

A NEW Fordham 'Eterna' cistern in 2½ and 3 gallon capacity has been added to the products of Fordham Pressings Ltd., Dudley Rd., Wolverhampton. All the latest refinements are incorporated, including improved levers, specially designed bottom feed and bottom overflow if required, and choice of right hand or left hand operation.



There is also a choice of side feed and side overflow, or bottom feed and bottom overflow. The new model is available with "Acquasave" ball valve or M.O.H. or B.S.S. valve depending on local requirements. The "Acquasave" like the "Eterna" is made in plastic. Full details of the new Fordham "Eterna" and other Fordham sanitary equipment may be had on application to the Company.

★ ★ ★

ALL SISSONS' sinks are made from solid, heavy-gauge Sheffield stainless steel. Usual features are splash-back

and anti-drip mould; strengthened sound deadened drainers; radiused corners to bowls, etc. Understructure is of tubular mild steel or stainless steel. Mild steel understructures can be galvanised or enamelled. Sissons sinks can be fitted on stainless steel or stove enamelled cabinets.

A range of stainless steel hand basins is produced. Catering and industrial sink bowls can be made to any size and required shape. Any stainless steel sink can be made as a sterilizing unit heated by gas, electricity or steam. Sissons are also suppliers of the well-known "Whirl-a-Waste" commercial food waste disposers. These are available as free standing units, or can be incorporated into dishwash tabling or sink drainers.

In the production of heavy duty stainless steel sinks, Sissons Ltd., St. Mary's Rd., Sheffield, have all the facilities to design and manufacture to exact requirements. The Irish agent is Mr. C. Brinsley-Sheridan, 10 Hubert Place, Dublin.

★ ★ ★

THE VOGUE HARMONY is a rectangular top bath with hard wearing porcelain enamelled inside and on roll, and plain painted outside, prepared for ¾" pillar taps—taps at centre; 1¼" overflow and 1½" waste.

The overall height with a 1½" trap mounted above the floor is 20¾". With the trap below the floor the height may be reduced to 16½". For centre trap position, porcelain enamelled cast iron panels are available with chromium-plated corner and end pieces.

Continued overleaf

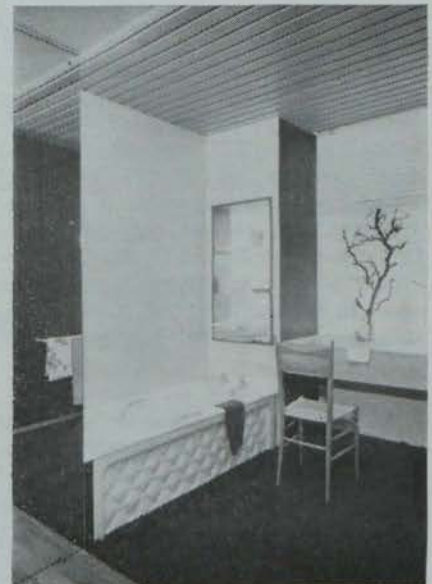

Twenty-three

The bath is non-handed, enabling it to be suitable for left and right fixing positions. The quilted panel—illustrated here—is optional. From Allied Ironfounders Ltd., Bath Division, Cadbury Rd., Sunbury-on-Thames, Middlesex.



Illustrated here is the Vogue Royal Bath by Allied Ironfounders Ltd. It features a chromium-plated safety rail which can be adjusted to any one of three positions—diagonally across the bath, along the wall edge from centre to foot or along the wall from centre to head.

A special anti-surge roll formed in the inside of the drop front allows maximum depth of water without danger of splashing on the floor. The minimum height of drop front is only 13½". It is a bath which can be used with confidence by the elderly, the infirm, and the very young.

★ ★ ★

FROM THE range of Reinforced Plastic Developments we note the "Dolphin" shower cubicle, moulded in glass fibre reinforced plastic. All exposed metal parts are deep chromed. Each single unit comprises four plastic parts, two sides, back section and base.

Plastic parts are bolted together; mastic strip ensures water tightness at joints. The overall standard size is—width 2'8½" or 2'3½"; height, 6'7" and depth (back to front) 3'0½". The weight without plumbing assembly is approximately 60 lbs. (Waste outlet fitting is 1½"). From Reinforced Plastic Developments, Middle St., Shere, Surrey. The agent in Ireland is Mr. C. B. Sheridan, 10 Herbert Place, Dublin.

★ ★ ★

A NEW and practical development in sanitary fittings is the Swanlyne Masque unit which is provisionally patented and design registered, and is available at present only for use with the 24" x 20" Swanlyne Vitreous China flat top basin manufactured by Alfred Goslett

SANITARY WARE

From previous page

and Co. Ltd., Charing Cross Rd., London.

Advantages listed of the new fitting are that the joint between Masque and basin is concealed. The Masque is made in vitreous China matching the basin and is fixed with one wood screw at each side. The price is the same as a pedestal.

The Masque conceals completely supply pipes and trap, whether viewed from front or sides. It fits below the basin and is a cover only, not a support to the basin which is fixed in the usual manner on wall hangers and centre waste bracket.

★ ★ ★

THE NEW and unique back rest slope of 35 degrees, of the model Regina 5'7" steel bath enables the enjoyment of a full bath in the most comfortable position.

With a lesser outer width of approximately 2'3" of all models from Messrs. Rankwerk, Koln, Germany, and the enlarged bottom width of about 1'8" the best possible bath is produced.

The nesting ability of the bath has been greatly improved by the new design. The patented Ranke fixable cradles enable an irremovable mounting of the bath and prevent the wall tiles from cracking off the bath rim when the bath is used.

Built-in- baths may be equipped with centre end tap holes and hand grip holes is required. The Irish importers and agents are T. J. Kennedy Ltd., 23 Lower Ormond Quay, Dublin.

● THREE ITEMS which we note from the range of John Stevenson and Sons Ltd., Cledford Works, Middlewich, Cheshire, and illustrated here are (a) The Pedestal lavatory basin. Size 24" x 20", it is a luxury flat topped basin with clean modern lines. It can be supplied without pedestal for use with C.P. legs. (b) A wall basin for maximum bowl area where space is restricted. Sizes available are: 14" x 10" and 18" x 11" in white only; and 20" x 12" in white and colours. (c) This is a large flat-back urinal with lip.

● A FULL range of sanitary fixtures manufactured in "Westwood" fireclay is available from John Slater (Stoke) Ltd., Berry Hill, Stoke-on-Trent (Staffs). An illustrated booklet shows a selection of the current patterns in sanitary ware designed and manufactured to meet the demands in the home and overseas markets. Irish agent for John Slater Ltd. is Mr. C. Brinsley Sheridan, 10 Herbert Place, Dublin.

CALUMET TRADING COMPANY Limited (41 Upper Mount St., Dublin) are agents in Ireland for the Lavet, the amazing multi-purpose product of Ocrietfabriek N.V. of Holland.

This unit combines the following functions: Washhandbasin, dressing table, sit-showerbath, foot bath, shower, baby and childrens' bath, baby dressingtable, washing machine and spindryer.

The Lavet combination is the answer to compact bathroom design giving all the facilities required in the smallest possible space—3 ft. 8 ins. x 5 ft. 2 ins. is sufficient space to install the unit.

Another Ocriet product—a circular wash fountain—is also available from Calumet trading. Twenty-four men can wash in ten minutes using only one fountain.

★ ★ ★

THE FULL range of Twyford's Sanitarywares is available from their agent in Ireland, Mr. T. R. Ievers, Corby, Corr Bridge, Sutton, Co. Dublin.

Twyford's Sanitarywares provide full coverage of this field and many of their patterns are included in the cross-channel Design index.

★ ★ ★

THE ANDREW BROTHERS (Bristol) Ltd., Carlton Works, Regent St., Liverpool 3, ranges of kitchen furniture are the Elizabeth Ann 18" range and the Elizabeth Ann 21" range.

The 18" range includes a sink unit, single drainer, S/S top without overflow, 36" x 18½" x 36", R.H. or L.H. or sink unit, double drainer, S/S top 54" x 18½" x 36" without overflow.

The 21" range includes sink unit, single drainer, S/S top without overflow, 42" x 21" x 36", R.H. or L.H. or sink unit, double drainer, S/S top without overflow, 63" x 21" x 36".

A 'MAID' MAKES IT EASY



Here's a sink that sells itself on sight! Modern design, superbly finished with deep mirror polish. Also available—42" x 18"; 42" x 21" handed; 54" x 21" double drainer; 42" x 18" reversible. In addition to the above Sinks, Stainless Steel Bowls are available in a number of sizes for setting into plastic table-tops. Elegant and inexpensive.



63" x 21" Stainless Steel Sink with double drainer.
MADE IN THE REPUBLIC OF IRELAND.

HAMMOND LANE

INDUSTRIES LTD., 111 PEARSE STREET, DUBLIN 2.

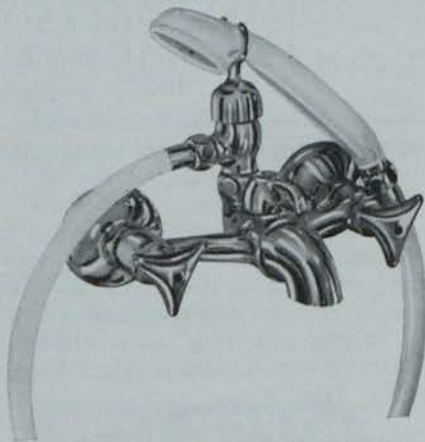

GROHE



SANITARY FITTINGS

Reliable - Functional - Elegant

Detailed information is available from our Irish representatives:

**Norman Stewart Ltd.,
Central Hotel Chambers,
Dame Court, Dublin.
Telephone: Dublin 73086.**

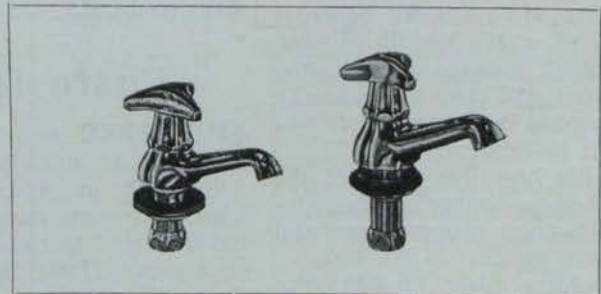

Agents in Ireland of:

FRIEDRICH GROHE ARMATURENFABRIK
GROHE THERMOSTAT GMBH
HANS GROHE KG.

Hemer/Westf.
Lahr/Schwarz.
Schiltach/Schwarz.

Soft soldering

THE COMPOSITION AND USES OF SOFT SOLDERS

See also B.S. 219. Non-Antimonial Solders

the easier and better the soldering work will be. A 2 lb. "bit" is none too large for most jobs of soldering in plumbing.

When using the heated copper bit on the work, take care to apply it so that as much heat as possible can flow in a short time. Avoid using only the pointed end of the bit but, rather, apply one of the large, tinned, flat faces to the work.

Heating

TINNING the "bit" is done by heating it to the correct temperature, filing its four flat faces clean, rubbing them into powdered sal-ammoniac, and at the same time touching the surfaces with solder. As to the correct temperature, red-hot is too hot. The tinsmith of old used to judge the heat by holding the "bit" some inches from his face—a practice which is **not** recommended as a safe one.

Judgment of heat comes from experience. A lively "sizzle" of the flux when the heated copper bit is inserted, is a fairly good indication that the temperature is correct. If the "bit" is too cold the solder will not melt or run, and if it gets too hot its tinning will burn off, leaving a dirty oxide film. The oxide is a poor conductor of heat, and will not attract the solder, so that soldering will be very difficult, if possible at all.

Solders

A WIDE range of solders for soft soldering are available. Mixtures or alloys of metals, chiefly of lead, tin, and small amounts of antimony, or just lead and tin, are generally used, depending on the type of soldering that is to be done.

The table here lists some of the more common plumber's solders, together with their proper fluxes and uses.

These solders might contain very small amounts of iron, arsenic and copper. If the quantities are kept below the limits laid down in B.S. 219, the solder will prove satisfactory.

B.S. 219 Grade	% Composition			Melting Temperatures		Typical uses
	Tin	Antimony	Lead	Solid	Liquid	
				'Plastic' range		
A	65	0.6	The Remainder	361	365	Electrical and radio work
K	60	0.5		361	370	
F	50	0.5		361	414	
G	40	0.4		361	453	Copper bit soldering Tinning unions, etc.
J	30	0.3		361	491	Blowpipe soldering, for example, in gas fitting work
<i>Antimonial Solders</i>						Plumber's wiped joints on lead pipework
B	50	3.0		365	399	As for Grade F above
M	45	2.7		365	419	As for Grades F and B
C	40	2.4		365	441	As for Grade G
L	32	1.8		365	469	As for Grade J
D	30	1.7	365	478	As for Grades J and L	

Note: In plumbing, Grade F is commonly used for copper bit work, and Grade D for wiped joints.

mium, or zinc might also be present, and these could affect the working properties of the solders, making them faulty in use. Such impurities would not be acceptable in solder made to the B.S. 219 specification.

Paste fluxes

POWDERED resin is difficult to apply to soldering work, especially work in awkward positions. Liquid fluxes are more easily applied, but they tend to run away from the joint area. Paste fluxes avoid both these difficulties and for this reason are more commonly used in plumber's work.

Resin dissolved in alcohol provides a non-corrosive flux for radio and

electrical work. The addition of small amounts of oleic acid to this provides a more active, corrosive flux for general soldering work. Oleic acid is an organic acid obtained from animal fats.

Other paste fluxes are formed from zinc chloride and ammonium chloride in solution with petroleum jelly. Alternatively, tallow or lanolin, a fatty substance obtained from wool, may be used as the base to carry the more active flux ingredients.

All fluxes are corrosive to a degree, since some acidity in the flux is very necessary to the chemical reduction, that is, the dissolving and removal of the metallic oxides, which the flux

Continued opposite



Shown here is the Zone-A-Trol Air Flow Damper Actuator.

ZONE-A-TROL RANGE NOW AVAILABLE

ZONE control with accuracies of plus or minus one degree F., using simple miniaturized equipment of elegant design, is now available. The Zone-A-Trol range covers through valves, three-way mixing valves, and a specially designed high torque damper actuator motor for ducted warm air systems. The control thermostat is designed to blend with modern fittings and incorporates special electrical features to ensure simplicity with precision accuracy.

The control signal from the thermostat operates either the motorised three-way mixing valves or, for warm air systems, the damper actuator, both motors of which are designed with ease of maintenance in mind. The cover, driving motor and valve unit is easily removed from the valve

TRADE

TOPICS

body when installing, and simple multicore cable is used for connection purposes.

The system is designed and engineered by Thermocontrol Installations Company Limited.

Irish agents: The Accurate Recording Instrument Co. Ltd., 6 Montague St., Dublin.

1962 DIRECTORY OF MANUFACTURERS, AGENTS, ETC.

A limited number of copies of our June issue containing the 1962 Directory are still available, price 5/-.

Applications for extra copies should be sent immediately to Irish Trade and Technical Publications, 13/15, Dame Street, Dublin, 2.

from previous page

Soft soldering

aims to bring about in the soldering processes.

"Safe fluxes" are those which are not aggressively corrosive in use or in after-effect.

Tallow and resin are generally regarded as safe fluxes because although they are sufficiently acidic at soldering temperature, they do not corrode most metals at ordinary room temperature.

NEXT MONTH

A. L. TOWNSEND ON:

ALLOYS USED
IN PLUMBERS
WORK

NEXT MONTH

THE COMPOSITION AND USES OF FLUXES FOR SOFT SOLDERING

Flux	Uses	Notes
Resin.	Tinning brass and copper.	Resin is a gum-like substance obtained from pine tree bark. It is used in powder form, and is sprinkled on surfaces to be tinned. It is mildly corrosive at soldering temperature, and non-corrosive when cold.
Tallow.	Soldering on lead.	Tallow is obtained from the fat of animals, particularly cattle and sheep. These organic fats contain glycerin, which makes them mildly acidic.
Zinc-chloride (killed spirits)	All forms of copper bit soldering except electrical work.	Produced by dissolving zinc in hydrochloric acid. Dangerous hydrogen gas fumes are given off during this process. The flux is actively corrosive and must be completely removed by washing the soldered article to remove all traces of flux.
Zinc-ammonium chloride (killed spirits plus 10% ammonium).		This flux is 'active' at a lower temperature than killed spirits; this is helpful in soldering metals with a relatively low melting point, such as zinc. It is as corrosive as zinc chloride, and similar treatment of the articles is needed after soldering. Most of the proprietary liquid fluxes are of this composition.

NEW SYSTEM COMBINES HEATING, LIGHTING

A COMBINED heating and lighting system has been produced as a result of the pooling of their resources by Copperad Ltd. and the Benjamin Electric Co. Ltd.

"Raylite" as the combined system has been designated, comprises a double run of Copperad Raystrip continuous strip heating surface between which is mounted a length of Benjamin Taskmaster lighting trunking. To the trunking are fitted tubular fluorescent or other types of lighting fittings to give continuous strip or spaced lighting as required.

Installed

Additional runs of heating or lighting strip can be installed as conditions dictate. The Raystrip heating equipment as incorporated in Raylite is designed for operation on steam at high and low pressures and on hot water at temperatures up to 360 deg. F. or more. Heat outputs range from 372 B.t.u. per hr. per ft. run using l.t.h.w. up to 1,416 B.t.u. per hr. per ft. run using steam at 150 lb. per sq. in. gauge.

Similarly by suitable choice of lighting fittings illumination levels can be chosen to suit the levels required.

Spare channels

In addition to accommodating the lighting distribution mains, the Taskmaster trunking also contains spare channels for other wiring. Pipework such as heating or domestic hot and cold water pipes, compressed air and gas, etc., can be accommodated on roller sets fixed to "Raylite" support brackets. The standard length of Raylite is 20 ft. with make-up lengths of 15 and 10 ft.

● "The Principles of Forced Circulation in Hot Water Heating Systems" is available to Contractor readers at a nominal 3/6 per copy charge from International Boilers and Radiators Ltd., Earlsway, Team Valley, Gateshead. It comprises 55 pages of easy to follow information with sketches, illustrations, tables and the like.

TRADE

TOPICS

THERMOMETER MODIFICATION

A modification to their pipeline thermometer, which enables the instrument to withstand higher temperatures and to offer greater resistance to corrosion, thus widening the range of application, has been introduced by the British Rototherm Co. Ltd.

This thermometer—Model 5/25—designed for use in pipes or tanks carrying liquids or gases, is now available with a stainless steel pocket-type stem and boss, attached to the head.

The pipeline thermometer has a 2½ in. dial and can be ranged in Fahrenheit, Centigrade or with a dual scale if required. Two stem lengths are available—2¼ in. and 3 in.—

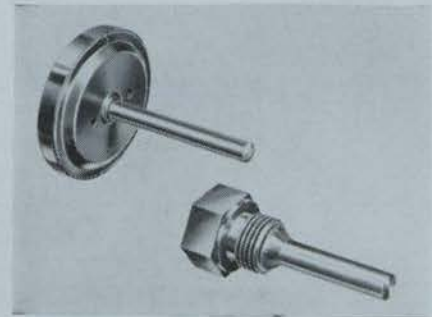

measured from under the hexagon, in all the standard temperature ranges.

Irish agents: Rototherm Precision & Instrument Co. Ltd.

WELDING TECHNIQUES



In no other branch of Engineering do so many individual problems arise as they do in Welding. We are equipped to give you a first-class Service on all your Welding problems. We supply and service the best equipment in this ever-widening field. We offer you the most up-to-date plant from the leading manufacturers in many countries.

WELDING SERVICES LTD.

14-16 Amiens St., Dublin. Ph. 47051-2-3



FOR use on concealed plumbing installations Walker Crossweller & Co. Ltd. of Cheltenham have introduced this special version of their "Leonard 72" thermostatic mixing valve.

The original (fully exposed) design of this unique British valve, which combines both thermostatic control of water temperature and flow control in one concentric unit—thus dispensing with the need for separate taps or non-return valves—was first introduced to the British market some months ago.

This new version has been designed to meet the growing popularity of concealed plumbing methods.

Irish agent: Modern Plant Ltd., Crumlin Road, Dublin.

QUESTIONS ANSWERED

from page eight

LONG HORIZONTAL RUNS OF PIPING

In the case of plumbing systems where there are long horizontal runs of piping in the attic and there is no room to raise the store cistern, would you think it all right to carry the expansion pipe of the hot water system as high as possible (to prevent siphonage) and then down into the cistern under water level. This would prevent air from entering the expansion pipe when a hot tap is opened and would be handier and cheaper than bending a coil.

THIS question poses the problem which is all too common: how to prevent spasmodic outflow to taps when long high level horizontal runs are involved. The answer lies only in correct pipe-sizing if the cistern just cannot be raised. An article on pipe-sizing is prepared and awaiting space for publication. When this appears the solution to this trouble will become clear and easily applicable. Briefly, to overcome the frictional resistance of long pipe runs operating under low head conditions one must increase pipe size of those runs. It is not uncommon to find on detailed examination of this problem that, although a 1in. pipe may be adequate for the down cold feed, a 1½in. or even 1¾in. pipe may be required for the high level horizontals. It may sound paradoxical, in fact it is—strange but true. The article referred to will, when followed by worked examples to illustrate just this point, make this quite clear.

Danger is attendant upon the suggested "cure." (See question above). If the open end of the expansion pipe (the writer prefers "Vent" pipe) be submerged in water, and then the water freezes over—what then? The system has become hermetically sealed. The system no longer operates at atmospheric pressure plus static head, and the consequences of this could be grave indeed. Please don't do it!

Furthermore, to prevent siphonic motion of cistern water to vent pipes

would necessitate raising the vent 34ft. See "The Atmosphere" (June, '61, issue) of the Contractor. Failure to do so would result in low pressure development in the undersized horizontal pipes as taps are opened and atmospheric pressure would then push water from the cold feed cistern into the vent pipe and along to the taps. The result—tepid outflows at taps although there might be plenty of hot water in the hot store vessel.

Application

AN INFORMED application of pipe-sizing is the only cure for

this nuisance complained of. Querist's reference to bending a coil is not understood, unless he is suggesting, as the writer has sometimes heard it suggested, that by increasing air passage resistance by extending the vent pipe in lengthy coil formation, will stop the passage of air to taps. This, it is respectfully submitted, is an erroneous view; it is tantamount to suggesting blocking up the vent. This, incidentally, would do the trick as a cork placed in the vent pipe end will show.

But do not leave the cork there otherwise the system becomes sealed off and the essential vent function—to let air enter and leave the system—is as surely stopped as the freezing over of a submerged vent outlet just described. Furthermore, the cost of extra pipework to form this coil would—as like as not—be more than extra cost to fit correctly sized high level pipes in the first instance.

PUMP HAS A LONG DELIVERY

In the case of a pump having a long delivery and passing points where water is required, would you say it is all right to fit a bottom delivery to storage tank with a suitable gate valve there, and a non-return valve at the pump head to stop leakage at the glands? The necessary branches to taps being taken off the double purpose delivery pipe as it runs to the tank.

THE dual purpose pump delivery and subsequent back supply pipe principle is sometimes used in waterworks practice. A pump may be used to raise water to a high level reservoir. When this is filled the pump will be automatically cut out and by virtue of bottom entry of the delivery, this same pipe serves as distribution main for properties adjacent to its run. If water is drawn when the pump is in operation, it matters not whether the water is from one source or the other.

The writer can see no valid reason

for objecting to this idea being applied at domestic level providing suitable precautions are taken. A good quality re-flux valve of full bore flow will be needed not only to relieve static pressure on the pump glands, but to retain the water in the high level store cistern. A safety or relief valve is **essential** on a valved pump delivery unless the pump be of a suitable centrifugal type.

The variation in water pressures as between pumped delivery and gravity backflow, may be disconcerting to the users, even, in some circumstances, quite dangerous. The writer has in mind such domestic water heating appliances as gas equipment dependent upon water pressure for operation of automatic gas-water valves assemblies.

On the whole, and without knowledge of querist's full intended scheme, the writer would recommend the more conventional arrangement of free delivery over high level store cistern with separate valved distribution to connected services.

QUESTIONS ANSWERED—Continued page thirty-one

The Irish Plumber and Heating Contractor.

VOKES offer guaranteed correct solutions to air filtration problems

VOKES 'RENOVAIR' SMOKE REMOVAL UNIT

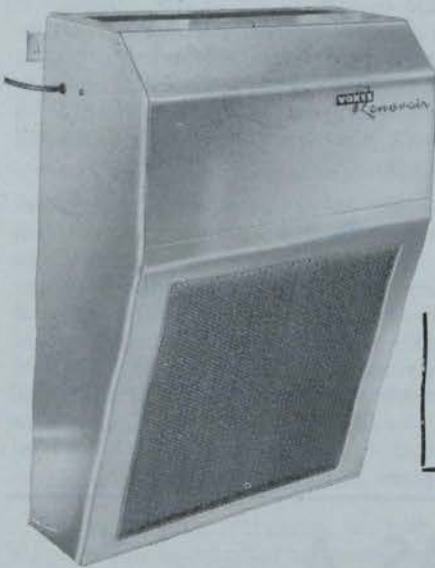

The 'Renovair' is the latest addition to the comprehensive range of Vokes air filters, and is ideal for use in meeting halls, offices, restaurants or any building or room where people congregate. Simply switch it on and it completely clears tobacco smoke and other airborne contaminants from the atmosphere within a few minutes. And

because the Vokes 'Absolute' filter in the 'Renovair' cleans air which is then recirculated, heat loss is eliminated with consequent saving on heating bills. Please write for descriptive leaflet. Other Vokes filters widely used in air conditioning and ventilating applications include:—

S.C.—A completely automatic filter for handling large quantities of air.

Super-Vee. — An inexpensive expendable filter panel suitable for many industrial applications.

K.600 Kompak. — A high-efficiency filter unit with replaceable filter medium.

Autoroll. — An electrically or manually operated filter combining high efficiency with low operating costs.

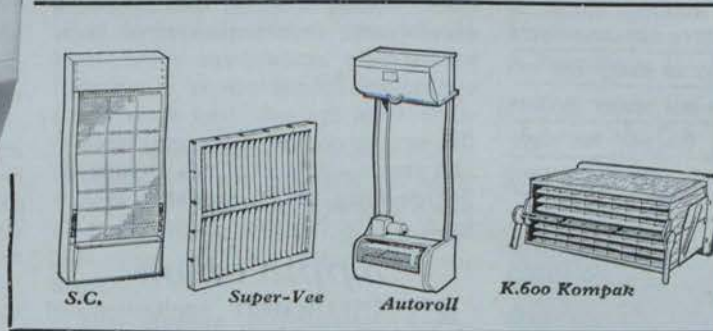

Full technical data available from the Sole Agents:

THE LEINSTER ENGINEERING CO., LTD.

158-159 CHURCH STREET, DUBLIN, 'Phone 77093/4.

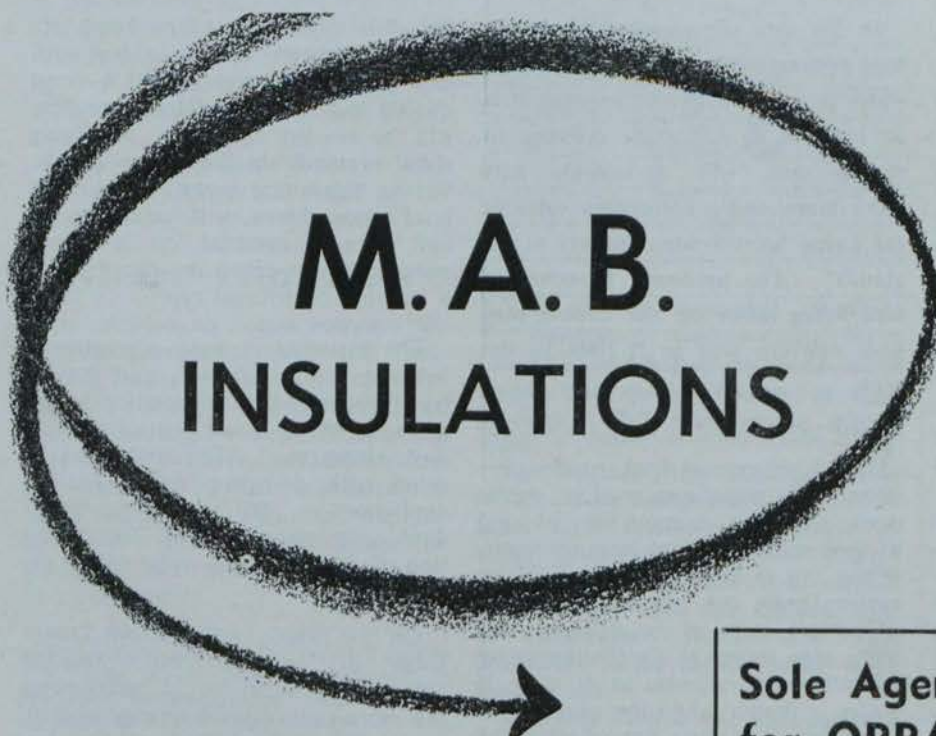

Insulation Contractors & Sheet Metal Specialists

**Sole Agents in Irish Republic
for OPPANOL Waterproofing
for Insulated Pipe Lines**

Estimates and Specifications Free on request.
45, WATERLOO ROAD, BALLSBRIDGE,
DUBLIN. Telephone: 684017.

QUESTIONS ANSWERED

from page twenty-nine

Space heating a bungalow

Reader proposes to space heat a new bungalow which is some 1,300 ft. super floor area. He wishes to know whether underfloor heating would be better than radiators or skirting ducts.

EITHER of the above mentioned heat emission forms could be adopted for a domestic dwelling not yet in process of building. Each would prove satisfactory though each would have certain advantages, and possibly some disadvantages not possessed by the others.

Costs, both capital and running costs, will need some consideration. Without going into too much detail on this aspect one might expect the radiator system to be cheaper to instal than skirting heating. This is based on radiators in modern slim pressed steel form at about 5/- per sq. ft. of heating surface, and skirting radiators at about £1 per ft. run. Floor warming by embedded L.P.H.W. heated grid or serpentine coils needs special attention in floor construction if wasteful heat losses to external walls and to the substructure are to be avoided. The cost of this work may prove expensive. When added to the actual cost of pipework, ancillary equipment, etc., such a system may be found a bit "pricey."

Capital cost

However, if capital cost is not of prime importance then the floor-warming system has much to commend it. It provides comfortable "all-over" warmth. If heated by oil, solid fuel boiler, or gas, and each room thermostat controlled, there will be considerable measure of heat emission control at all times. The system is completely unobtrusive. The floor space is unrestricted in any way. With a suitable blender valve to control water temperature input to the floor cells at about 100 F. a floor surface temperature of around 75 F. will result. This provides the desirable "warm feet and cool head"

conditions so typical of warmed floors. (See "Special Survey," Dec., 1961, issue and "Radiant Heat," page twenty of that issue).

A circulating pump will be necessary with floor warming by L.P.H.W. but it would be needed for skirting heating as well. In the interest of neatness of pipework and pipework economy, a pump would be recommended for a radiator system too and so the pump cost enters all three systems under consideration. Three-quarter inch B.S.1386 copper tube would perhaps be used; the larger diameter would reduce the frictional losses in the coils. It would also offer greater heat emission to the floor slab and thus improve flexibility of temperature control.

Advisable

Spaced at 9ins. centre to centre, or according to more exact design requirements (the thermal insulation values of the proposed bungalow were not given, neither were required performance figures) this should do quite well. It is advisable to space the coils closer together, say 6ins., centre to centre, below windows. This will give extra warmth at these "cold spots." As a matter of interest, it is known that systems of this kind have been installed using $\frac{3}{4}$ in. polythene tube, but unfortunately no results of operating are yet available.

Skirting heating is unobtrusive; it dispenses with the need for conventional timber skirtings, and it offers a pleasing and efficient heat emission system. The encased finned type heat exchangers are very effective and 500 B.t.u.'s per ft. run are not uncommon.

It may well prove, therefore, that the output to a room may need less skirting or "Wallstrip" appliance than the whole room skirting length, or even the one external wall length, might be. In such cases one selects sufficient of the encased finned tube to meet the heating load for the room and uses plain casing which accommodates the $\frac{3}{4}$ in. heating circuit pipe. In this way the heating elements can

be dispersed at strategic points around the room, or along one wall of the room, and continuity of casing applied for appearance sake alone.

The cast-iron skirting radiators are more on the conventional radiator design principle but they are also very efficient. In both cases this is largely due to the fact that the appliances are fitted at floor level where the air is cooler and the consequent heat transfer from appliance to air is greater. (See "Heat—Its Effect on Air and Water," page six, Nov. issue).

Convected

Radiators offer chiefly convected warm air heating as opposed to the mainly radiant emission component of warmed floors, and to skirting systems which offer a combination of both. (See "Special Survey," "Oil Fired Heating Systems," Nov. issue). Radiator systems are well known and there is no need to elaborate.

The Copper Development Association of 55 South Audley Street, London, W.1, offers useful free publications dealing with small bore radiator systems, skirting and "Wallstrip" systems. It has just published an original work on "Radiant Heating" and this too is free.

Although correspondent did not mention it, ceiling heating might have been considered but since this gives, or tends to give, a feeling of oppression if used with ceiling heights of less than 10ft., it is hardly the job for a domestic dwelling.

No doubt, careful consideration will be given to the proposed standard of thermal insulation in his new bungalow. (See Page 10, Nov. issue). A little extra cost to improve thermal insulation will save pounds in heating running costs later. It is so much cheaper and more effective to do this at the design and construction stage than later on.

Finally, before making a firm decision on either of the above mentioned heating arrangements, why not consider one or other of the economic and flexibly controlled warm air systems. These can be operated from L.P.H.W. with conventional boiler and D.H.W. systems or can be used as separate heating units on electricity, oil or gas.



...for **CENTRAL HEATING**

he cannot buy better
than the

SIGMUND THERMOPAK or SILENTFLO

and the prices are very competitive. Why not buy the best at practically no extra cost?

SPECIAL FEATURES:

- Super Silent and self-lubricating.
- Being glandless, is free from leaks and needs absolutely no attention whilst operating.
- Special silicon-impregnated winding—no starter protection needed.
- Precision-ground sleeve bearings—for long life.

PRICES AND ILLUSTRATED LITERATURE SENT ON APPLICATION.

ONLY AVAILABLE FROM THE SOLE AGENTS FOR REPUBLIC OF IRELAND:

MONSELL, MITCHELL & CO. LTD.

67-73 TOWNSEND STREET, DUBLIN 2.

Phone 76282

Fully guaranteed and complete after sales service available by our own technical engineers.

Thermal Insulation

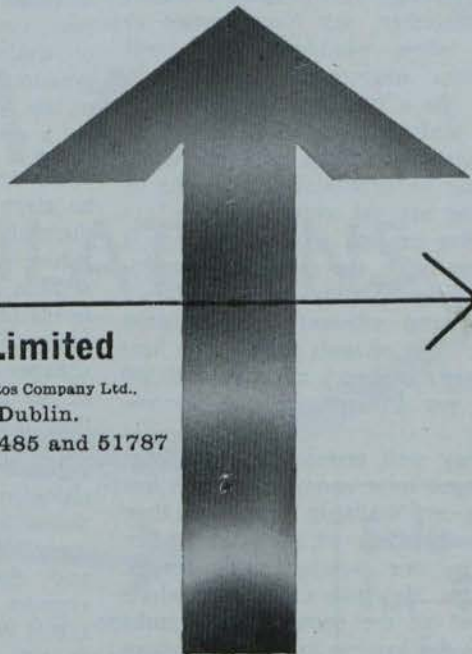

M. A. Boylan Limited

A subsidiary of The Cape Asbestos Company Ltd.,
50a Harcourt Street, Dublin.
Telephone: 52397, 54485 and 51787



We are the foremost insulation specialists in the country with many important insulation contracts to our credit. The huge Oil Refinery at Whitegate and the Derrinlough Briquette factory are recent examples. If you have any heat-loss problem, discuss it with our highly experienced technical staff. Our recommendations are offered free and without obligation.

Sole agents and stockists for:

- 'Rocksil' rock wool
- Rigid Sections
- Flexible Sections
- Blankets
- Mattresses (wire-mesh-backed)
- Loose Wool
- 'Caposite' amosite asbestos moulded blocks and pipe sections
- Also full range of plastic materials and hard-setting compositions.

the premises before the arrival of staff. Some of the more advanced systems even take into account local meteorological conditions, adjusting the plant to cope with the vascillating conditions of weather.

Since the first HEVAC exhibition last year, where more than 45,000 experts visited the show, including 1,345 from 60 overseas countries. The industry has dealt with some £7,000,000 of enquiries which were initiated at Olympia, the organisers report.

The Contractor will be covering the Olympia exhibition, supported as it is by a strong Irish contingent.

Now here is a preview report of some of the exhibits.

Improved filter

Vokes Limited: The principal exhibits will be the new improved version of the Rotary Viscous Screen filter—the S.C. Mk II, the Miniroll automatic air filter, the Microwire and Microdisc liquid filters.

The new S.C. filter is an improved version of the original design and employs a number of specially designed all metallic panels which pass through a trough of oil where a very high degree of self-cleaning is achieved by means of a unique cleansing device (patented) incorporated in the trough. It also includes an automatic sludge removal device which eliminates sump cleaning. The S.C. Mk II has wide application in single and multiple air conditioning and ventilating systems.

The Microwire is a fully motorized self cleaning liquid filter which is available in four sizes with automatic or continuous operation and the Microdisc is an edge type filter which can easily be cleaned without dismantling or interrupting the flow.

Support hanger

Vokes Genspring Limited: A feature of this Company's exhibits will be the 'G' Type Constant Support Hanger and the Pre-Set Variable Spring Hanger, both of which now incorporate pre-setting and locking devices. This simplifies and speeds up site erection and enables hydraulic tests to be carried out on pipelines without deflection of the pipe or spring.

The 'G' Type Constant Support Hanger can carry loads up to 98,000 lbs. The Pre-Set Variable provides

TRADE

TOPICS

From page thirteen

HEVAC PREVIEW

safe economical support for applications not critical enough for constant supports, but where some provision for the effects of thermal expansion must be made.

A big one

Allied Ironfounders: The central feature of this stand will be an industrial boiler, the Kayenco NSB 45, ranking as one of the largest items in the whole exhibition. This shell boiler, capable of raising 4,500 lb. of steam per hour, is specially constructed and packaged to suit a client's specific requirements.

Allied Ironfounders plan to exhibit several entirely new appliances yet to be announced. However, products already well-known in the industrial and domestic heating field and others only recently introduced are also to be shown. These include a Watts 500 A/C gravity-fed solid-fuel boiler, and the Kayenco LR series oil-fired boiler. They also show examples of the Aga solid-fuel and gas domestic boilers; the restyled Agavector warm air heater; the Aga electric oil-fired radiator; and the Company's latest central heating appliance, the Allied water radiator.

Time switches

Venner Ltd. are showing a comprehensive range of time switches, designed for both Industrial and Domestic use. Four new items will be shown for the first time; the Thermal Dial Switch, the 'R' Switch, a new version of the Ven-O-Set which incorporates a plug and socket, and a new switch in the Autopoint range.

In addition, both Standard and Minor versions of the Central control

Units will be shown. These have been introduced to provide convenient automatic time switch control of electric space heaters in individual rooms, from a central point.

Registers, grilles

Greenwoods and Airvac Ventilating Co. Ltd.: This company will display an entirely new range of registers and grilles in extruded aluminium and steel for heating and air conditioning systems. This range is being marketed under the trade name of "Greenwood's Lloydaire".

New Greenwood Airvac powered roof extractors to be displayed on this stand will include the "Mechavent" Roofline Mk II and the "Mechadome"—a dome-light extractor.

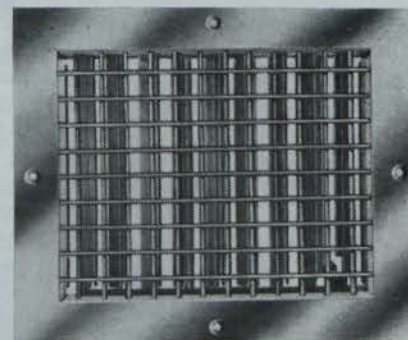

Picture shows: Greenwoods Lloydaire type L.557 Double deflection supply register—horizontal face blades, vertical rear blades, and opposed blade damper.

Convection unit

F. H. Biddle Limited: In keeping with their progressive outlook towards technical developments this company are introducing new products which will have their preview on the stand.

Outstanding amongst these is the new Centrifugal Forceflo convection unit. The entire range of new Forceflos has been independently tested by Acoustical Investigation and Research Organisation Limited in their large reverberation chamber to internationally accepted noise criteria standards. For the first time, guaranteed, certificated proof of noise levels emitted by each of the entire range of new Forceflos, with the fans running

Continued page thirty-five

The NEW

Boss-Rad

66

Circulator



“The most advanced design in the circulator field today”

- ★ **SLIMLINE** — Compare its size with other pumps
- ★ **NEW ‘OUTPUT REGULATOR’** — One pump covers 95% of all small-bore heating systems
- ★ **‘HYDRAMATIC’** — Starting/running action
- ★ **REVERSED FLOW LUBRICATION** — Keeps bearing free from dirt

AND IT'S **Low Priced**

Write for full details to:—

THE BRITISH STEAM SPECIALTIES LTD.
33 LEESON PARK, DUBLIN. Tel. 66961. Also at BELFAST

The Nobel range

Beautifully Designed—

Technically Perfect—

NOBEL 31 (right) — Output 48,000 B.T.U./Hr. Will heat up to 12,000 c.f.t. of a normally constructed building.
Price: £36-10-0 ex Dublin.

NOBEL 24 (bottom right) — Output 32,400 B.T.U./Hr. Will heat up to 8,000 c.f.t. of a normally constructed building. Has an incorporated oil tank.
Price: £29-8-0 ex Dublin.

OTHER UNITS AVAILABLE

HOT AIR GENERATOR (left) — Output 120,000 B.T.U./Hr. Ideal for workshops, spaces, stores, garages, glass-houses, etc.
Price: £149-10-0 ex Dublin.

For further particulars apply to:

DOMESTIC HEATING LTD.

31 UPPER BAGGOT ST., DUBLIN, 4.
Telephone: 683977, 680067.

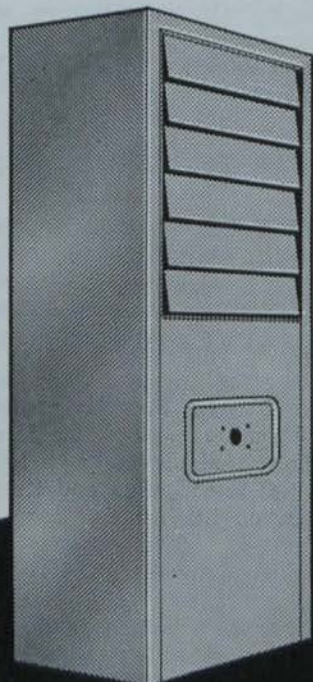

TRADE

TOPICS

*From the Contractor's
Northern Correspondent*

BACK TO WORK AGAIN

IN the North the plumbing trade—in line with the rest of the building industry—have returned to work now after their annual holiday.

Last month we reported a tremendous flood of enquiries in recent weeks and news of reasonably substantial contracts. An indication of this welcome state of affairs is probably the expansion of within the trade to meet these demands. For instance, two further new companies were registered recently:

● A new Company—the Heating Development Co. Ltd.—plans to carry on the business of heating, electrical and plumbing engineers and contractors, etc.

Details of the company are: Registered office—not stated (Northern Ireland). Nominal Capital—£4,000 divided into 4,000 shares of £1 each.

Names and descriptions of Subscribers to memorandum and Articles of Association: (Subscribers of Five shares each)—James Smith, heating engineer, 23 Ross St., Belfast; Roseann

McBurney, married, and William McBurney, trader, both of 8 Hillhead Park, Belfast; John Smith, heating engineer, 6 Erinvale Drive, Belfast.

Names of First Directors—not stated.

● A second registration is that of William H. Leech and Son (Manufacturers agents) of 414 Ravenhill Road, Belfast. Partners here are—William H. Leech, 414 Ravenhill Rd.; Allenby S. R. S. Leech, "Tigin", Saintfield Rd., Ballylenaghan, Belfast.

Free service

PETER MacFarlane and Son Ltd., of 23-27 Cupar St., Belfast, advise that they are agents for Afos Ltd. of Hull—makers of the "Air line" warm air system—who provide a free design service which is particularly helpful to heating engineers and plumbers who do not employ draughtsmen.

The Afos 'Air line' ducted system provides heating, ventilation, summer cooling, air filtration and domestic hot water. Its heat output is 34,000 Btus/hr (equal to 10 1KW electric fires) and is

sufficient for a house of 1,500 sq. ft. floor area. The unit runs on domestic fuel oil.

Afos also manufacture a full range of air heating units (fourteen sizes) with outputs of from 40,000 to 2,500,000 Btus/hr.

Appointed

MR. A. B. MURPHY, who for the past eight months has been a director of Davidson and Co. (Africa) (Pty.) Limited, manufacturers of Sirocco fans and dust collecting equipment for mines and industries, has succeeded Mr. W. C. Massie as Vice-Chairman of the company.

Mr. Murphy, a chartered accountant, is well-known throughout the South African business world as a leading figure in the financial, mining and engineering fields.

The Chairman of the Davidson organisation in South Africa is Mr. E. D. McGuire, Chairman of the parent company in Belfast.

from page thirty-three

HEVAC PREVIEW

at all speeds, are available.

The new Forceflow is neat and compact being only 9" deep and 28" high. It consists of a motor, centrifugal fans, filter, high efficiency two row coil and sheet metal casing. The coil is of copper tubes and aluminium fins and is sloped inside the cabinet to give maximum heat transfer surface. Either hot water or steam can be used as a primary heat source.

The re-designed Warmline unit will be another feature on this stand.

Strip diffuser

Thermotank Ltd.: One of the features of this exhibit is a display of the Thermotank range of air distributors, louvres and grilles. A particularly attractive item is a flush-mounted continuous strip diffuser available in a variety of finishes.

unit from the range of packaged equipment available from Thermotank's Land and Products Division will be operating in conjunction with a Thermotank all-plastics cooling tower which contains a revolutionary lightweight fill. One of the recently-introduced heat pump units can also be seen in operation.

HAS RETIRED

Mr. Giles Newton, Chairman of The Cape Asbestos Company Limited, has retired on medical advice. He is 71 and had been Managing Director since 1933 and Chairman since 1957. He joined the Company in 1931 as General Manager. He has been asked to accept the office of Honorary President.

Mr. R. H. Dent, F.C.A., becomes Chairman and Managing Director, and Mr. S. D. H. Pollen has been elected Deputy Chairman.

TENDERS

Copper roofing

TO Copper Roofing Contractors—Tenders are invited from Copper Roofing Contractors for laying approximately 14,000 sq. feet of copper roofing to No. 2 Division building at St. Brendan's Hospital, Upper Grangegorm, Dublin, in accordance with the drawings and specification prepared by Vincent Kelly, B.Arch., F.R.I.A.I., F.R.I.B.A., Architect, 98 Merrion Sq., Dublin, from whom copies of the tender documents may be obtained. Sealed tenders will be received by F. J. McCullough, Secretary, Dublin Health Authority, St. Brendan's Hospital, Upper Grangegorm, Dublin 7, not later than August 31 next.

Tenders are continued overleaf 37

TENDERS *From previous page*

Water supply

LONGFORD County Council—Ballymahon Water Supply Improvement Scheme: Tenders are invited for the supply and installation of the following plant for the above scheme in accordance with specification prepared by E. G. Pettit, B.E., M.I.C.E.I., M.Cons., E.I., 7 South Mall, Cork, from whom documents may be obtained on deposit of £10 (refundable).

2 No. Pumping sets consisting of low level centrifugal pumps and electric motors each having capacity of 50 gallons per minute against total head of 30 feet, together with all accessories, fittings and pipe work.

2 No. Pumping sets consisting of two high level pumps and electric motors, each having capacity of 50 gallons per minute against total head of 122 feet approximately, together with all accessories, fittings and pipe work.

Tenders in sealed envelopes, endorsed "Ballymahon Water Supply Scheme, Tenders for Pumping Plant" will be received by the Secretary, Longford County Council, County Home, Longford, up to, but not later than 5 p.m. on September 7 next.

Heating installation

Office of Public Works—Heating Contract: Sealed tenders addressed to the Secretary, Office of Public Works, 51 St. Stephen's Green, Dublin 2, and receivable up to noon on August 28 next are invited for an L.P.H.W. heating installation at the Glasshouses, Aras an Uachtarain, Dublin, in accordance with plans, specification and conditions of contract exhibited at this Office. Plans and specification may be obtained from the Secretary on deposit of £1 (refundable).

BIDDLE ADVANCE IN HEATER DEVELOPMENT

F. H. Biddle Limited have just announced a major step forward in the development of a forced convection unit heater capable of functioning at a predictably acceptable noise level, and with a satisfactory heat output, whatever the application.

Their new range of Forceflos were sound level tested in the large reverberation chamber of Acoustical Invest-

igation and Research Organisation Limited. The total energy emitted by the unit as noise was measured, at all speeds, and sound levels were established across the entire octave band spectrum.

The sound pressures obtained during the tests were plotted against internationally accepted criteria curves, so that for the very first time accurate guaranteed noise levels are available on every unit throughout the new Forceflo range. Selection of unit size has been simplified by plotting graphs for each unit showing B.T.U. rating, C.F.M. and N.C. range, so that even if only one factor is known the other two can be easily obtained. The units are fully adjustable over N.C. 25 to N.C. 43 noise criteria range.

CASING

The Forceflo consists of a motor, centrifugal fans, filter, high efficiency 2 row coil and sheet metal casing. The coil is of copper tubes and aluminium fins and is sloped inside the cabinet to give maximum heat transfer surface. Either hot water or steam can be used as a primary heat source. It is neat and compact, only 9" deep and 28" high maximum heat outputs through the range are from 29,500 to 62,000 B.T.U.'s per hour, based on 60 deg. F. entering air and 180/160 deg. F. water, depending on the model size.

Convector and Direct Hot Air Heating Units

—By

P O T E Z

These attractive heaters are available in three models as detailed below. They are operated on paraffin or domestic diesel oil. Fumes go up the chimney and only pure, beautiful, hot air is distributed throughout the home, factory or glasshouse.

- Model No. 331. Output 17,280 B.T.U./h. Heated space up to 4,945 cu. ft. (corrected volume). Extra flat model. New type patented heat exchanger. Fuel tank and draught regulating shutter incorporated. Price £28.
- Model No. 631. Output 24,640 B.T.U./h. Heated space up to 7,770 cu. ft. (corrected volume). Price £38.
- Model No. 7R1 (as illustrated). Heated space up to 12,713 cu. ft. (corrected volume). Price £48-5-0.



Model No.

7R1

Output 37,440 B.T.U./h.

Distributors:

THE HOUSE OF ROWAN

M. Rowan & Co. Ltd., 51-52 Capel St., and 1-2 Westmoreland Street, Dublin. Phone 41891 (10 lines).

BIG 4 FOR ALL PLUMBING & HEATING CHOSEN BY CRAFTSMEN

1

INSTANTOR

the most efficient joints in the world for copper tubing. Equally reliable for use with plastic pipes.

2

ENDEX

capillary fittings for small-bore central heating—efficient, unobtrusive and cheaper to install.

3

CONEOR

go underground with safety. Coneor couplings are zinc-free gunmetal castings specifically chosen for use with soft copper tubing.

4

FYFFE'S

up-to-date range of *PLUMBERS' BRASS WARE* is at your stockist's now. All patterns can be supplied—polished or chromium-plated.

ADD THEM UP TO A FIRST CLASS JOB

IT PAYS TO KEEP TO THE FYFFE LINES

Fyffe Couplings (Ireland) Ltd.

Instantor Works, James's Street, Dublin, 8.

LOOK HIGH
AND
LOW...



* The "Eterna" is
officially approved by
Dublin Corporation.

Fordham Plastic Cisterns have all you look for!

Fordham Plastic Cisterns are designed on smart compact lines to occupy the minimum space. They are non-corroding, lightweight, silent in operation, and fitted with all-plastic mechanism for life-time service. Available in white, black, as well as the range of Standard B.S.S. Bath Colours, to match any scheme of decoration.

For High Level specify the 'VOLTA'; for Low Level, the 'ETERNA'

For full details write to:- FORDHAM PRESSINGS LTD., DUDLEY ROAD, WOLVERHAMPTON Tel: Wolverhampton 23861/2

You won't find finer than
Fordham
CISTERNS