

7-1-1962

### The Irish Plumber and Heating Contractor, July 1962 (complete issue)

Follow this and additional works at: <https://arrow.tudublin.ie/bsn>



Part of the [Civil Engineering Commons](#), [Construction Engineering Commons](#), and the [Construction Engineering and Management Commons](#)

---

#### Recommended Citation

(1962) "The Irish Plumber and Heating Contractor, July 1962 (complete issue)," *Building Services Engineering*: Vol. 2: Iss. 4, Article 1.

doi:10.21427/D76125

Available at: <https://arrow.tudublin.ie/bsn/vol2/iss4/1>

This Article is brought to you for free and open access by the Journals at ARROW@TU Dublin. It has been accepted for inclusion in Building Services Engineering by an authorized editor of ARROW@TU Dublin. For more information, please contact [arrow.admin@tudublin.ie](mailto:arrow.admin@tudublin.ie), [aisling.coyne@tudublin.ie](mailto:aisling.coyne@tudublin.ie), [vera.kilshaw@tudublin.ie](mailto:vera.kilshaw@tudublin.ie).

# THE IRISH PLUMBER & HEATING CONTRACTOR



**MRS  
1970  
KNOWS WHAT  
SHE WANTS**



And she knows just where to get it. Because the hard hitting advertising which first sells her on the idea of installing Shell and BP Housewarming also tells her of the superb service offered by her local Appointed Installer. The special Shell and BP Appointed Installer's sign is prominently featured in each advertisement to help her remember it.

There are hundreds of Mrs. 1970's. All looking for the Irish Shell and BP Limited Appointed Installer's sign — the sign which they know means prompt efficient service. Hundred's of Mrs. 1970's—hundreds of systems to install and service. It's obviously very good business to give Mrs. 1970 what she wants!

## SHELL AND BP HOUSEWARMING

THE ORIGINAL SCHEME FOR OIL-FIRED CENTRAL HEATING IN THE HOME

IRISH SHELL AND BP LIMITED  
SHELL-BP HOUSE,  
13-15 FLEET ST., DUBLIN 2.

IRISH SHELL AND BP LIMITED



HOUSEWARMING PLAN



Look for this mark **S&L** it's your guarantee of quality and service.

## HAVE YOU EXAMINED THIS NEW PIPE ?

● It is Stewarts and Lloyds new High Density polyethylene pipe and it has many interesting advantages. ● Have you seen our literature? Telephone 46704 and we shall be pleased to send it to you. ● We can arrange for our Technical representative to call on you at your convenience.



**NEW HIGH DENSITY** polyethylene pipe

STEWARTS & LLOYDS OF IRELAND LTD., EAST WALL RD., DUBLIN 3. Phone 46704.



"Cavendish" Wash Basin

Design Registration No.890751

Dublin Representative—C. H. LOCKHART LTD.,  
75, Middle Abbey Street,  
DUBLIN, 1.

**Shanks**

**SHANKS & CO., LTD., TUBAL WORKS, BARRHEAD, SCOTLAND**

## CESSPOOL SUPERNATANT WATER

Because of its trouble-free performance and simple operation, the 'M' Mono Pump is a popular unit for small installations handling cesspool supernatant water. Offensive operating tasks are eliminated by reason of its single rotating part and the fact that it will operate without attention for long periods. There are no valves or glands to adjust. The unit is ideal for automatic control and its compact dimensions assist installation in any small garden structure or outhouse. The pump is moderately priced and the range will amply cover requirements for country houses, licensed premises, small housing estates and caravan sites.

*Attractive terms to Dealers.*

### **MONO PUMPS LIMITED**

MONO HOUSE, SEKFORDE STREET, LONDON, E.C.1.

Telephone: Clerkenwell 8911. Telegrams: Monopumps London Telex.

and at : Belfast, Birmingham, Bristol, Dublin, Durban, Glasgow, Johannesburg, Manchester, Melbourne, Newcastle, Wakefield.

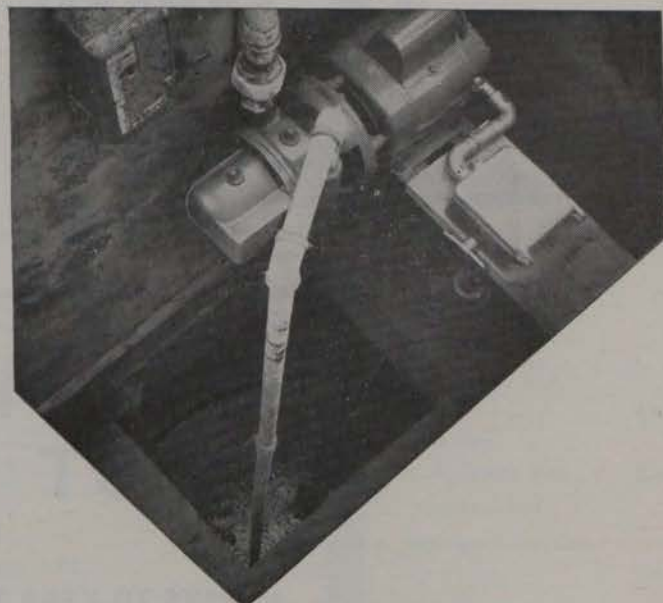

The  
**MONO**  
pump  
**M RANGE**

# BIG 4 FOR ALL PLUMBING & HEATING CHOSEN BY CRAFTSMEN

**1 INSTANTOR** the most efficient joints in the world  
for copper tubing. Equally reliable  
for use with plastic pipes.

**2 ENDEX** capillary fittings for small-bore central  
heating—efficient, unobtrusive and cheaper  
to install.

**3 CONEOR** go underground with safety. Coneor couplings  
are zinc-free gunmetal castings specifically  
chosen for use with soft copper tubing.

**4 FYFFE'S** up-to-date range of *PLUMBERS' BRASS  
WARE* is at your stockist's now. All patterns  
can be supplied—polished or chromium-plated.

## ADD THEM UP TO A FIRST CLASS JOB

IT PAYS TO KEEP TO THE FYFFE LINES

Fyffe Couplings (Ireland) Ltd.

Instantor Works, James's Street, Dublin, 8.



Vol. 2. No. 4.

The only publication in Ireland for the craftsman plumber and contractor, the heating, ventilation, insulation, air conditioning and refrigeration engineer and contractor, the electrical contractor, supplier, manufacturer and wholesaler of fittings and equipment for the trades.

Published monthly by Irish Trade & Technical Publications. Annual subscription, 21/-, post free. Single copies, 1/9, post free.

Editorial and advertising offices:

Callaghan Chambers, 13/15 Dame Street, Dublin, 2. Tel.: 56466, and 133 Royal Avenue, Belfast.

Tel.: Belfast 22796.

JULY, 1962.



# THE IRISH PLUMBER & HEATING CONTRACTOR

## IN THIS ISSUE

Trade Topics, the column that keeps you in touch, begins on page .. .. .	4
Cast iron and its repair by gas welding is the subject of John G. Bolton's contribution this month .. .. .	7
A. L. Townsend, M.R.S.H., M.I.P., takes further aspects of roofwork for discussion ..	8
Our Northern correspondent reports: "It's holiday time here," on page .. .. .	31
Questions Answered, see page .. .. .	27

Trade Topics continued on pages 5 and 6.

SPECIAL SURVEY: Air conditioning, refrigeration—Insulation materials.

## INDEX TO ADVERTISERS

Airnesco Products Ltd. .. .. .	32	Kelly, Dan & Co. .. .. .	6-29
Andrew Air Conditioning Ltd. .. .. .	14	Leinster Engineering Co. Ltd. .. .. .	13
Boylan, M. A., Ltd. .. .. .	34	McAuley & Cunningham .. .. .	22
British Steam Specialties Ltd. .. .. .	30	Mono Pumps Ltd. .. .. .	1
Carthorn (1949) Ltd. .. .. .	35	Monsell, Mitchell & Co. Ltd. .. .. .	29
Chemical & Insulating Co. Ltd. .. .. .	19	Quadrant Engineers .. .. .	Cover iv
Cox Engineering Co. Ltd. .. .. .	36	Rowan, M. & Co. Ltd. .. .. .	26
Cor-Tex Proofers Ltd. .. .. .	20	Sanbra-Conex (Ireland) Ltd. .. .. .	Cover iii
Crowe, W. and L., Ltd. .. .. .	15	Slater, John (Stoke) Ltd. .. .. .	35
Fyffe Couplings (Ireland) Ltd. .. .. .	2	Stewarts & Lloyds of Ireland Ltd. .. .. .	Cover ii
Fibreglass Ltd. .. .. .	21	Shanks & Co. Ltd. .. .. .	1
Greenwoods & Airvac Ventilating Co. Ltd. .. .. .	17	Shires & Co. (Ireland) Ltd. .. .. .	23
Gypsum Industries Ltd. .. .. .	18	Technical Equipment Co. Ltd. .. .. .	33
Heywood, W. H. & Co. (Ireland) Ltd. .. .. .	16	Thompson, John (Wilson Boilers) Ltd. .. .. .	30
Irish Shell and B.P. Ltd. .. .. .	Cover i	Unidare Ltd. .. .. .	11
Irish Equipment Co. Ltd. .. .. .	6	Wavin Pipes Ltd. .. .. .	26
		Welding Services Ltd. .. .. .	5

Three

TRADE

TOPICS

## NEW WAVIN FACTORY OFFICIALLY OPENED

**T**HE official opening last month of Wavin Pipes' new up-to-the-minute factory at Balbriggan marks an important, and outstanding, engineering and industrial achievement. For, just four short years after this firm set up in smaller premises in Drumcondra (Dublin) the Taoiseach, Mr. Lemass, was declaring their large and impressive Balbriggan factory officially open.

Wavin Pipes Ltd. in that short time have established themselves both on home and overseas markets as leading manufacturers of polyvinyl chloride plastic products.

An Irish-Dutch organisation, Wavin Pipes Ltd. was incorporated here in 1958. For the previous 18 months or more pipes had been imported from the parent factory in Holland so that the Irish market could be fully tested and the advantages of PVC pipes demonstrated to the waterworks industry.

### Cooperated

**T**HE Department of Local Government co-operated fully, laying down specifications under which the Company has operated ever since, and issuing an instruction that all future water supply schemes in this country should include an alternative price for hard PVC pipes.

Production began with well-filled order books, the result of preliminary marketing, in July of 1958, at temporary premises in Drumcondra. Business was transferred to Balbriggan towards the close of 1961 and since then the main problem facing the factory management is a continually increasing demand on production.

Branch offices have now been established in London, Liverpool and Belfast and a substantial export trade to England and the Continent has been developed.

A wide range of watermains are

produced by Wavin and fittings from 2in. to 8in. are available. As well as being used for the water supply the pipes have extensive usage in agriculture for irrigation purposes. The advantages of P.V.C. pipe are many. They are competitively priced, economical to work, lay or instal and, of course, very light. They are also immune to corrosion and attack by most known chemicals, soil acids, etc., thus easing maintenance problems.

**F**OR domestic plumbing Wavin supply fittings from  $\frac{1}{8}$ " to 2in. Another product is ducting for air-conditioning and ventilating. Wavin also have, at an advanced stage of development, a wide range of rain-water goods which will be self-coloured. One of the latest products to be developed is a P.V.C. bag for



● Mr. John A. Findlay, Designer, (centre) pictured with the Warm Air Free Standing Unit at the 'A' Line Vacation House. Also in picture are (right) Mr. E. W. Pigot, Domestic Heating Supervisor, Irish Shell and BP Limited, and Mr. J. J. Balding, Manager, Irish Plumber and Heating Contractor.

## SHELL HOUSEWARMING IN IRELAND'S FIRST A-HOUSE

**I**RELAND'S first packaged 'A' Line House was opened at Cornelscourt on the Dublin/Bray Road early this month by Senator E. A. McGuire. The house has been erected on the car-park site of "The Magic Carpet" (Cornelscourt) and is open for inspection by the public.

On the ground floor, the French doors of the 20 ft. high living room (18' x 16') and of the main bedroom (18' x 19') lead on to a sun deck which provides additional outdoor living space. A second bedroom is situated upstairs.

The house is heated by a Perkins oil-

the fertilizer and other industries.

After the official opening the guests were entertained to luncheon at the Holmpatrick House Hotel, Skerries. After the Taoiseach had proposed the toast of the company, Mr. T. MacMahon, chairman and managing director, replied. Mr. J. C. Keller of the Waterworks Co., Overijesel, also replied. The toast of the guests was proposed by Mr. D. McIlvenna (director), and this was replied to by Mr. T. Murray, chairman of the E.S.B.

**Historical note:** The name Wavin is derived from the word "water and vinyl"—taking the first two letters of water and the first three of vinyl.

The soil in Overijesel, Holland, is very corrosive and it has been found that steel and cast-iron pipes have a short life, which creates a considerable problem in pipe maintenance. Mr. J. C. Keller, chief engineer and general manager of the Waterworks Company, Overijesel, decided to try to manufacture good-quality pipe from P.V.C. and after much work the factory went into production.

fired warm air free standing unit—situated outside the house—from which the air is passed through floor level grills in each room. Installed by Duawoody and Dobson Ltd., through the Irish Shell and BP Limited Housewarming Plan, the system can also be used as an air conditioning unit in the summer.

Designed by: John A. Findlay; Irish Concessionaires: Raben & Co., Ltd., St. Stephen's Green; and Manufactured by: T. & C. Martin Limited, D'Olier Street; Under Licence from: K-D Homes (London) Ltd.

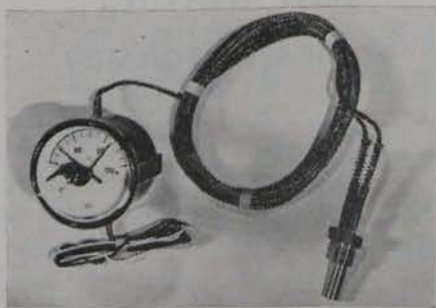

O.B.C. LTD., heating equipment merchants, have been appointed the sole distributors of the new Stork "Combistat," combined thermostat and thermometer, manufactured by Stork Fernthermometer, Suttgart Sud, West Germany (pictured here).

The "Combistat" combines temperature measurement and control in one small instrument using hand-set or pre-set micro-switches and is automatically actuated by connecting direct to mains voltage at 220/250 volts A.C. 5 amp. Remote pockets can be supplied for use in air, gas, oil, water or solid mediums, while the capillary with its extra small bore and standard double-copper wound sheathing is extremely flexible and capable of being bent in any direction without affecting the working of the instrument.

The "Combistat" is designed for the remote operation of automatic plants where it replaces the normal contact thermometer and thermostat or relay and is ideal for small bore hot water installations, hot air systems, and ventilation and air conditioning.

### CAPE ASBESTOS INCREASE TURNOVER

TURNOVER throughout the Cape Asbestos Group of Companies in 1961, including for the first time a full year's sales of Small & Parkes, Ltd., increased by 16 per cent., states Mr. Giles Newton, Chairman, in the Group's Annual Report. Net profit of the Group after deducting all charges except taxation amounted to £1,702,619. The same total dividend was declared for 1961 as for 1960—22½ per cent.

### VENNER'S PACKAGED BOILER CONTROL

THE Packaged Boiler control Unit Mark II, now introduced by Venner

## TRADE

## TOPICS

Ltd., is easily adapted to suit the various small oil-fired and gas boilers designed for automatic control by thermostat which had been introduced in recent years. The unit provides a closer control over heating procedure than has hitherto been possible.

The packaged unit comprises a neat panel fitted with a time switch, miniature sockets for connecting the various remote circuits, and a 6-way rotary switch. The five sockets provide connections for mains input, room thermostat, solenoid gas valve (or oil burner) and accelerator pump, thus considerably simplifying the external wiring. This special facility enables a valve or circulating pump to be changed by the hot-water engineer without recourse to an electrician.

Irish agents are Roper Bros. Limited.

### POWELL DUFFRYN AGENT APPOINTED

MR. D. H. SULLIVAN, of Green Park, Coleville Road, Clonmel, Co. Tipperary, has been appointed Irish Agent for Powell Duffryn Heating Ltd., manufacturers of the well-known "Janitor" solid fuel and oil-fired boilers and "Gulf" radiators.

Mr. Sullivan will also be responsible for the distribution of "Hurseal" electric appliances in the Republic of Ireland except Dublin City and County.

● Over 1,000 Gas Board officials, heating engineers and builders' merchants have attended receptions held by Powell Duffryn Heating Limited, at Sheffield, Bristol, Cardiff, Southampton and Torquay in the last month, to launch the brilliant new range of Janitor gas-fired boilers known as 'The Four Graces.'

### SOLID FUELS DEFENDED ON T.E.

AMONG the speakers in a recent edition of "Newsview" on Telefis Eireann was Mr. James J. Hussey of Thos. Heiton & Co. Ltd., who answered questions in defence of solid fuels as a major cause of air pollution in our cities and towns.

### NEW HEADQUARTERS FOR STERNE

THE spacious new headquarter premises at Hanover Street, Dublin, of Messrs. L. Sterne & Co. Ltd. were officially opened last month by the Chairman of the Company, Mr. David D. Frame.

This Irish company was founded jointly in 1948 by L. Sterne & Co. (Scotland) Ltd. and Hammond Lane Foundry Co. Ltd. A full range of the most modern equipment in the field of refrigeration is on display at their new premises.

## WELDING TECHNIQUES



In no other branch of Engineering do so many individual problems arise as they do in Welding. We are equipped to give you a first-class Service on all your Welding problems. We supply and service the best equipment in this ever-widening field. We offer you the most up-to-date plant from the leading manufacturers in many countries.

### WELDING SERVICES LTD.

14-16 Amiens St., Dublin. Ph. 47051-2-3



**TRADE**

**TOPICS**

**WATERPLAY  
INSTALLATIONS**

TECHNICAL SALES COMPANY of 79 Lr. Leeson Street, Dublin, announce that they are in a position to offer a complete service in respect of the comprehensive range of Waterplay Installations, equipment and figures.

The service includes the planning and construction of small and large Waterplay Installations, including rotary pumps, ceramical gargoyles and groups of animals, underwater illumination in white and changing colours and manual and fully automatic water organs. This range is manufactured in Germany by a Hanover concern.

● Mr. D. W. McCaffrey, M.A., M.A.I., A.M.I.C.E., A.M.I.C.E.I., has been appointed Sales Director of W. H. Heywood & Co. (Ireland) Ltd., structural engineers. He was educated at St. Gerard's School, Bray; Ampleforth College, and T.C.D.

**NEW HEATING  
COMPANY FORMED**

HEATWELL Engineering Co. Ltd. is a new company just registered with a nominal capital of £2,000. They plan to carry on the business of manufacturing and installing central heating boilers, pumping plants, etc.

Names and descriptions of Subscribers to Memorandum and Articles of Association—subscribers of one share each—Margaret K. O'Leary, married, and Arthur P. O'Leary, company director, both of Newland, Mount Merrion Avenue, Blackrock, Co. Dublin; Rory G. Brennan, heating engineer, 18 St. Enda's Park, Rathfarnham, Dublin.

The names of the first directors are not stated.

**Eliminate Noise**

**IN THE W.C. CISTERN AND ATTIC TANK BY FITTING A  
CRAIG SILENT BALLCOCK**

The **CRAIG SILENT BALLCOCK**—an outstanding invention—is completely silent in operation, it does not intrude when illness requires quiet, and guests no longer experience that disturbing sense of embarrassment created by old-fashioned noisy cisterns.

Ask **NOW** about the **CRAIG SILENT BALLCOCK**, it is simple and quick to instal, it fits any make of cistern. In this modern age of excessive noise the **"CRAIG"** performs a "New Silent Service".

Approved by B.W.A.  
and leading water  
authorities.

Trade enquiries to:—  
**IRISH EQUIPMENT COMPANY LTD.,  
BALLYMOUNT RD., WALKINSTOWN,  
DUBLIN. 'Phone 501548.**



# CAST IRON: ITS REPAIR

---

## BY GAS WELDING

---

**SO FAR**, in our discussions concerning the application of oxy-acetylene welding to the plumbing and heating industry, we have dealt with the process when applied to the jointing of mild steel and copper pipelines.

Very often, however, problems arise in the average workshop in connection with the repair of valves, appliances and castings made of various metals and alloys. This is particularly the case with fittings, etc., no longer in production and replacements not being obtainable.

We will therefore consider some of the other metals and alloys as to the feasibility of their repair by welding. In this article we shall deal with cast iron in its various forms.

### Widespread

**CAST IRON:** The widespread use of this metal for the construction of sectional boilers, pump castings, water and soil pipes, etc., renders it essential for the welder to have a knowledge of its "make up." It is, of course, one of the most familiar of present-day metals, although in recent years other materials have been put forward as substitutes—not always with success.

Primarily, it is an alloy of carbon and iron—the carbon being in the proportion of about 3%—but in its composition it is rather complex. It is well known, for instance, that even

a cast iron soil pipe will vary to a great extent in its structure—very evident indeed when we try to cut it with a hacksaw and meet a "hard spot."

Cast-iron is usually divided into three types—Grey Cast Iron, White Cast Iron, and Malleable Iron.

The grey cast iron is familiar to most of us, a common example being a fractured bath leg—the grey colour of the metal being clearly seen at the crack. This grey colour is due to the slow cooling of the metal after being cast. Every endeavour is made to keep the cooling rate as slow as possible, with the result that this type of cast iron is considered the best for most classes of work, being easily machined and with good mechanical properties.

When welding cast-iron we try, as far as possible, to produce this grey iron by pre-heating and very slow cooling of the job after welding.

### Cooled

**WHITE CAST IRON** gets its name from the white appearance of the metal when cracked. The colour comes from its being cooled down very rapidly from the molten state, and results in a hard, brittle casting unsuitable for plumbing or heating work.

It is important to remember that exactly the same result will occur if a

cast-iron weld should cool too quickly—a condition which must be avoided at all costs. In short, white cast-iron is of little value to our industry.

### Familiar

**MALLEABLE CAST-IRON:** This type is very familiar to us in the form of malleable fittings for steam, water and gas mains, and is manufactured by heating or annealing, for some days, special types of white cast-iron, so that a material is produced with some of the properties of steel and some of cast-iron. In brief, the malleable fittings have a layer of steel (low carbon iron) on the outside which permits a certain amount of "give" without danger of cracking, as would be the case with untreated cast-iron.

Unfortunately, it is not possible to fusion weld malleable iron without damaging its structure, hence bronze welding must be used here.

There are, of course, other elements such as manganese, silicon, phosphorous, and sulphur which may be present in cast-iron fittings, etc., but these do not normally cause trouble in welding. In general, it can be taken that most cast-iron fittings and castings will be of the grey iron type.

As to welding procedure, we have a choice of two methods—fusion welding or bronze welding. It is not an easy question to decide as a lot will depend on the type of job.

### Dismantled

**IF** A colour match is essential and the casting can be dismantled for pre-heating, then fusion welding using a cast-iron filler rod would be the ideal choice, but on the other hand, and this is important from the trade angle, bronze welding will often

*continued page twenty-four*

the  
author

**John G. Bolton**

Lecturer in Plumbing and Heating at the College of Technology, Bolton Street, Dublin.



## A. L. TOWNSEND M.R.P., M.R.S.H.

The author, a lecturer at Oxford College of Technology, continues the first part of a four stage course on plumbing.

# WORKING TECHNIQUES IN SOFT, HARD METAL ROOFS

**I**N comparison with iron, copper, zinc, and roofing quality aluminium, lead is relatively soft. This property of softness together with certain others—notably its high degree of malleability—allows lead to be worked in ways which cannot be extensively used with other metals.

Thus the commonly used plumber's metals can be conveniently classified as the "soft" metals—lead sheet and pipe, and the "hard" metals—copper, zinc, and aluminium sheet. To-day one talks of soft metal techniques of working—for example, the bossing of lead—or of the hard metal techniques which involve cutting and seaming of the materials in order to form similar details in the less malleable hard metals.

## Complicated

**Soft Metal Techniques in Roof-work.**—The ease with which sheet lead can be worked to complicated shapes under the skilled application of tools is one of its big advantages. Lead can be made to "flow" from one part of the sheet to another. In this way surplus lead can be bossed outward and away from where it is not needed, or bossed inward to provide additional lead where it is required.

**Setting out and bossing a simple corner in sheet lead.**—The working of a corner in sheet lead is the first step towards gaining the skill necessary for bossing. The best way to learn how to do it is to have a skilled plumber demonstrate and explain his aims as the work proceeds, but the following notes will be helpful if you have some lead and wish to practice

Our illustration shows the setting out necessary. The working procedure will direct you so that the job goes smoothly. With practice, especially under the supervision of an experienced plumber, you will soon gain the essential "feel" and mastery of the bossing techniques.

Assume that you have to produce a square corner—for example, one corner of a box with 4" sides.

1.—Square off two adjacent edges of the 4 or 5 pounds of sheet lead.

2.—From these squared lines mark in the 4" height of the sides to form the corner. These lines would best be marked by taking a chalked line and holding it taut against the 4" marks whilst someone else lifts the centre of the line. If he allows it to snap back smartly on to the sheet, some chalk dust will fly off and mark the line of fold.

3.—It will be seen that the small square in the corner of the sheet is not really needed. If it were cut out, the sides of the box could be bent up, and the corner would be formed as their edges touched. But this would leave the two edges to be joined in order to make them watertight, and the art of bossing lead is to form watertight details without applying any kind of jointing material. And so, although the small square is surplus, it cannot just be cut out. Some of it can be removed, and the rest must be bossed out.

Step 3 therefore consists of marking the quadrant line of surplus "cut off" at the corner.

4.—Place the lead on a soft bed,

such as a clean sack, and with a chase wedge set in or crease the fold lines. Notice that the chase wedge has a metal ferrule on its striking end. Do not use a bossing mallet to hit the chase wedge, or its face will be seriously damaged. Instead, use a hammer.

## Position

5.—Place a piece of 4" x 2" timber along the fold lines, and lift the sides to an upright position. This needs to be done a little at a time, lifting on each side so as to allow the surplus metal at the corner to be manipulated outwards in a smooth, round fashion. This roundness and smoothness is very important. Without it the lead will drive into creases or "cripples," and successful bossing will be impossible.

6.—Turn the folded "box" over, with the fingers of one hand at the inside bottom of the corner to get the feel of where you will be hitting. Use a dresser to "set in" the corner to about  $\frac{1}{2}$ " up its height. This clearly defines the corner, helps to stiffen it against the bossing action, and also helps to check on the size of the piece of bossed leadwork. Nothing is more annoying—or more wasteful in time, energy and material—than to boss or work any plumber's metal to shape only to find that it is either too big or too small for the job it was made for.

7.—While the "box" is still on its back, set in the "creasing" lines or "stiffening creases" about 2" in from

the folded edges. These creases will help the lead to keep its shape during the bossing process.

9.—Turn the box to a convenient position—this is very important, for everyone can work better if they are comfortable. Place the head of the dummy tool inside and against the bottom of the corner, and then with the bossing mallet direct blows systematically around the corner, gradually working out towards the free edge. The dummy is really a form of portable anvil, and, between it and the mallet the lead is bossed, “squeezed,” or “flowed” to where it is wanted—in this case out and away to the free edge where, as it collects, it can be cut off.

9.—Finally, the corner is dressed neatly square, but not too square in the angle. A slightly rounded corner is better able to accommodate the effects of thermal expansion and contraction than is a sharp corner.

## Tools required

### Steel try square.

**Rule.**—This would preferably be a two-fold steel rule, since it is more durable and more suited to plumber's work than a boxwood rule.

**Chalk line.**—This is best kept on a wooden reel or bobbin.

**Snips.**—These need to be about 12" long and of good quality. Snips are normally made for right-handed workers, who have the snips in their right hand whilst the left holds the material being cut off the sheet. Sometimes left-handed workers using right-handed snips have to cut the sheet off the surplus and this is so awkward that they unfortunately struggle against nature to use their right hand. Otherwise, they have to force the snips to cut the metal, using them incorrectly in their left hand. All this effort is quite unnecessary because “left-handed” snips are made, and although some inexperienced tool salesman might think you are pulling his leg in asking for them, they can get got and they are a boon to the left-handed plumber.

**Dresser.**—One with a 7" face length is quite large enough.

**Chase wedge.**—One with a 3" wide blade is quite a useful size to begin with.

**Dummy.**—This has a “hard lead”

from previous page

## ESSENTIAL TOOLS OF THE TRADE

head shaped rather like an egg, which is mounted on a malacca cane handle about 12" long.

**Bossing mallet.**—These are made in a variety of sizes, and are measured according to the diameter of the larger hemispherical face. A 1½" mallet will be found to move the lead just as effectively, and with less effort,

than the heavier, larger mallets.

An “eye” and a “feel” for quality of workmanship. These cannot be bought at the counter of a tool shop. They are nevertheless essential tools of the trade. Without them the best tools will not produce quite such good work.

continued overleaf

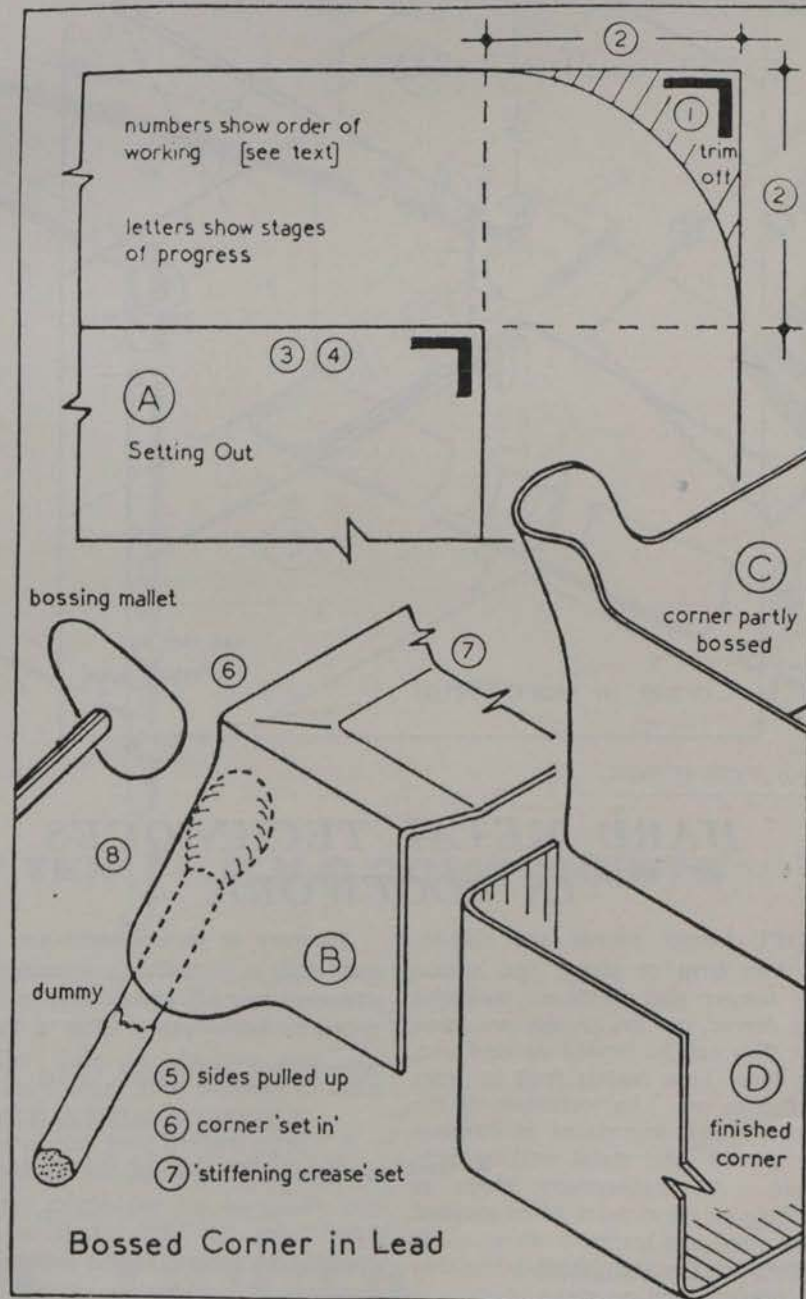

## Surplus

### CORNERS in hard metal roofwork.

—These are formed by the “dogear” method, in which the surplus metal is folded and turned back upon itself.

Our second illustration shows the setting out necessary, and the following sequence of operations should be helpful to the beginner.

1.—Square two adjacent edges of the sheet.

2.—Mark on the heights of the sides. This may be done in pencil.

3.—Optional. It will be found that if the diagonal line a—b in the surplus metal square is lightly chased, the folding process will be much easier since the metal tends to follow the line of the chase. A bricklayer’s brick bolster that has been blunted is useful as a chase wedge for this purpose.

4.—Using a block of wood as a support, pull up the sides. Pull both to an angle of about 45 degrees first, and then manipulate the surplus corner metal into a “dogear.”

5.—Having made sure that the fold is in the correct place, pinch it close with the seaming pliers. Finally, fold and dress it close to one outer side of the corner to complete the detail.

Practice this detail in stiff paper. It provides good experience at little cost and in a very short time. With experience thus gained, making corners in copper, zinc or aluminium will be no trouble at all.

#### Tools required:—

- Steel try square.
- Steel rule.
- Snips.
- Seaming pliers.
- Dresser.

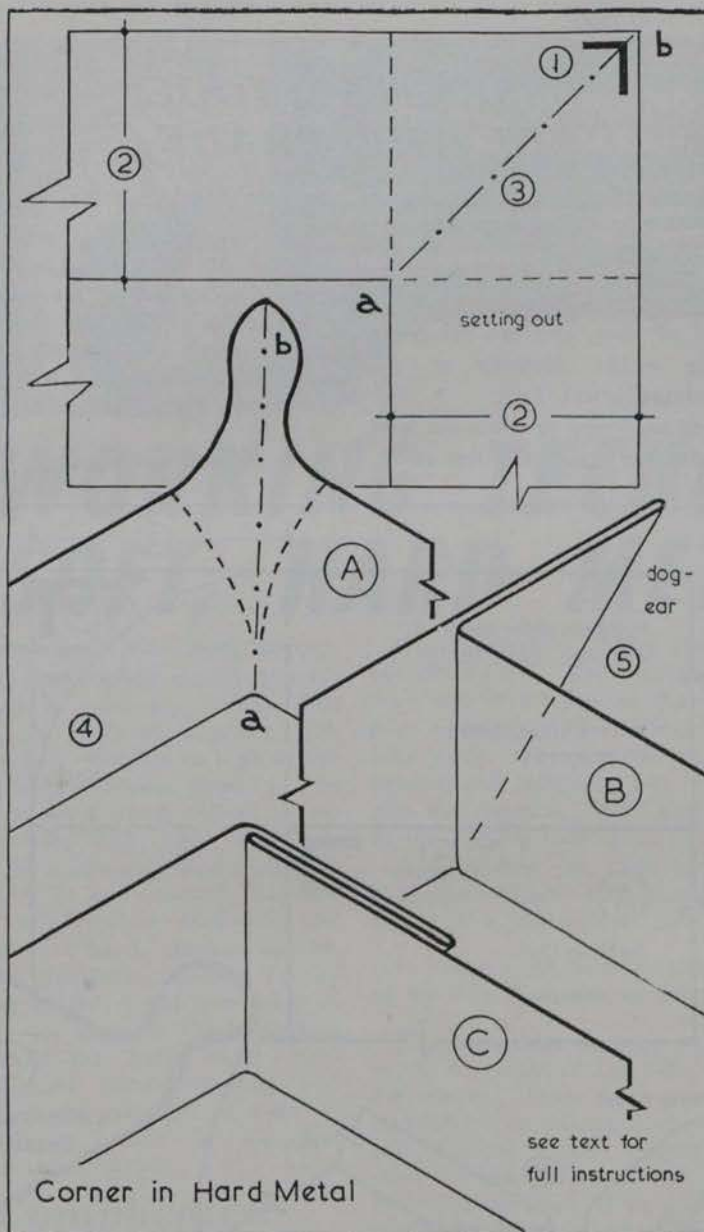

from previous page

## HARD METAL TECHNIQUES IN ROOFWORK

**S**OFT temper copper and aluminium strip or sheet, and special soft temper zinc sheet are malleable to a degree, but not to such an extent that they can be bossed as lead can. All these hard metals tend to work harden in use. An awareness of this is of the first importance in developing a hard sheet metal working technique. All unnecessary blows or working on the metal must be avoided. Very soon one learns to direct blows just where they are needed, when they are needed—and no more.

Accuracy in measurement and setting out is equally important, for whereas the soft metals may be adjusted to some extent after a detail has been worked, no such adjustment is possible with hard metal.

A clearly marked steel rule, a good try square, sharp snips, the knowledge and ability to set out angles, and a “feel” for the hard metals are all essential to success in this most modern type of plumber’s roofwork.

## NEXT MONTH

### SOFT SOLDERING

THE SOLDERING IRON  
SOLDERS  
FLUXES FOR SOFT  
SOLDERING  
PASTE FLUXES

## NEXT MONTH

**OFFICIALLY  
APPROVED**

*See it at the Horse Show*  
**STAND 243**



**TERRAIN**

in GREY, STONE and BLACK

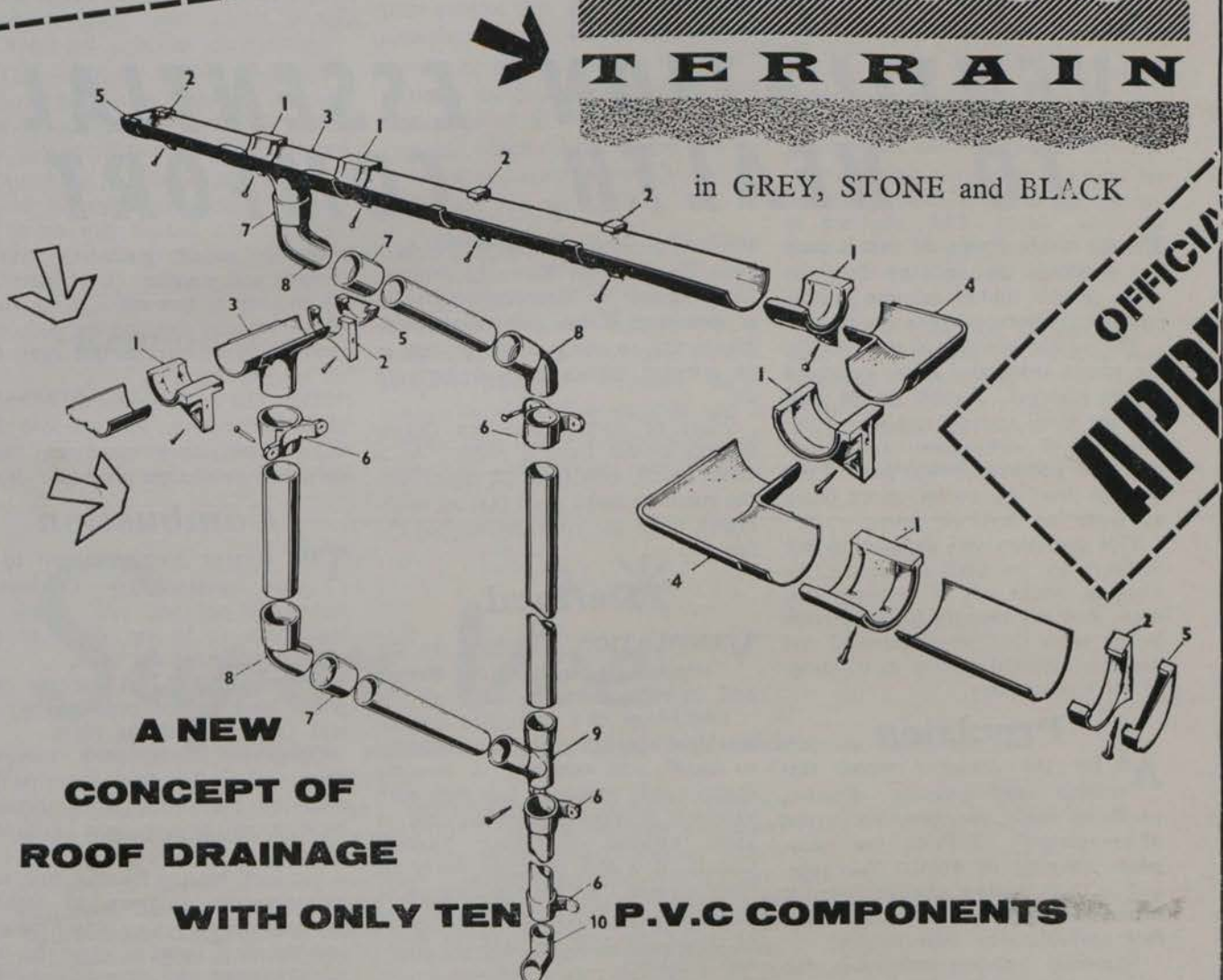

**OFFICIALLY  
APPROVED**

**A NEW  
CONCEPT OF  
ROOF DRAINAGE  
WITH ONLY TEN P.V.C COMPONENTS**

Terrain roof drainage represents the systematic approach. Ten basic units in the Terrain Range have been designed to take the best advantage of the particular characteristics of P.V.C.—rather than to produce copies of standard units—and to combine maximum efficiency with ease of erection.

**TERRAIN P.V.C. SOIL AND WASTE SYSTEM**

**TERRAIN P.V.C. VENTILATION SYSTEM**

\* Please avail of our advisory service

Terrain Systems are based on the use of unmodified, unplasticised P.V.C.

**UNIDARE LIMITED**

**FINGLAS, DUBLIN 11**

\*Phone 71801 (13 lines)



## AN IRISH PLUMBER & HEATING CONTRACTOR SPECIAL SURVEY

### AIR CONDITIONING & INSULATION MATERIALS

# VENTILATION ESSENTIAL TO HEALTH, COMFORT

**I**N the crude forms of man's early dwellings the cooking fire was often in the middle of the single, communal, living-sleeping room.

The visible smoke pollution of the air within demanded some provision for its removal. A hole in the roof was the usual remedy and by a combination of convection and stack effect the polluted air was pushed out at high level by cooler, more dense air from low level air inlets.

This provision was dictated to our forbears by the need to remove the choking smoke. It is unlikely that many had any thought for ventilation in the sense that we understand and use this essential service in buildings of all kinds to-day.

### Provision

**A**S for the draughts which this simple, and possibly effective, provision made, we have no record of complaints! Perhaps the occupants, sleeping on animal skin rugs, and in their outdoor clothes, found it better than sleeping outside and therefore bearable after their fashion.

Improved building techniques, the development of the brick or stone fire and, later still, the development of grates, relieved the situation a little. At least, when the wind was kind, the smokey room problem was alleviated.

But the draughts no doubt persisted. Even as late as Edwardian times, heavy drapes or door curtains were a prominent feature of room equipment—not so much as decor but as an essential barrier to incoming cold air.

Flues to open grates are thirsty suckers of air from a room. As a direct result, cold fresh air leaks into the room to make good that air withdrawn from the room by way of the fire.

### Defined

**V**ENTILATION is defined as the removal of used air from a space and its replacement by fresh air.

Ventilation, in a controlled or reasonably controlled amount, is essential to health and comfort. A howling draught may ventilate, but only with extreme physical discomfort and at great expense in space heating. Clearly, if a flue exhausts warm air from a room then the temperature of that room will fall as incoming cooler air enters by way of ill-fitting doors and windows.

**Ventilation rate** to provide adequate hygiene yet to minimise heating costs, are still subject to considerable laboratory research.

**The Edgarson Committee Report**

offers a sound guide to current thought and practice. It suggests that air movement through a living room of a domestic dwelling be such that each occupant receives 600 cubic feet of air per hour.

Thus, in a living room of 2,400 cubic feet volume four persons may enjoy satisfactory conditions with only one air change per hour.

### Combustion

**T**HE current problem seems to be that present day combustion techniques just will not enable air infiltration to be cut down to this still fall short of the ideal.

Improved solid fuel burning open grates have helped considerably, yet still fall short of the ideal.

Openable stoves, with complete control of air flow from room to flue, offer the best compromise between local room heating and economic ventilation rates.

But local heating by solid fuel, with its attendant drudgery of stoking, ash removal, etc., is no longer the only and the best form of space heating. Rightly, more and more householders demand central heating even in modified form, which provides full heating for the main room plus background heating for the rest of the house.



*This special survey—another in a series on important aspects of the plumbing and heating trades—has been compiled by technical expert A. L. Townsend, M.R.S.H., M.I.P.*

## Small bore

from previous page

**S**MALL bore force circulated heating, using L.P.H.W. radiator systems, has enjoyed a terrific boom. It still does. But now the discerning public seeks warmth comfort plus the invigorating sensation of adequate air movement plus economic operation.

Space heating and ventilation are inseparable services. Large buildings, office blocks in busy towns are a good example, often need double glazing to keep out airborne street noises.

This in turn means absence of natural ventilation since the windows are permanently secured shut. Mechanical ventilation has to be adopted.

Air from a clean air source is drawn through filters, washed, heated, or, in summer, cooled, and then fan-blown via ducts to the various offices or rooms.

## Economy

**R**ECIRCULATION ducts convey used air back to the "Plenum" plant, as such air treatment equipment is called, and some of it, still

warm, may be re-used to give a measure of fuel economy. By such means, the space heating and ventilation services are truly wedded to give complete control over all conditions of air save humidity. Even this is achieved simply by adding refrigeration equipment to the plant, which might then be termed an air conditioning plant, i.e., one which filters, cleans, warms or cools, and controls humidity of air discharged into the building.

A notable trend in domestic space heating and ventilation is the simplified embodiment of this principle. Air taken from the hall, where, by infiltration through front door fit, it is relatively fresh yet "tempered" so as not to be as cold as external air, is fan-impelled into a heater battery of some kind and then by way of short

ducts it is pushed into the room to be warmed.

## Propulsion

**T**HE mechanical propulsion of the air ensures even distribution of warmth, in a sort time after starting up the heating. The mechanical air movement ensures even and continuous, but barely perceptible, air currents which are notably freshening.

Gas heated systems of this kind are becoming much favoured on account of the care with which automatic control can be applied and because of the absence of fuel supply or fuel storage worries.

Many of these are of the furnace type—a refinement of heaters long favoured in American house warming practice. Others use gas to heat water which circulates to heat a

continued page fifteen

# Super-Vee\*

combats atmospheric pollution with guaranteed 96% efficiency at minimum cost

Vokes Super-Vee is an inexpensive, expendable air filter which, because of its unique medium, can offer up to 25% greater capacity compared with similar filters of the same size. This medium, impregnated with a specially developed adhesive, combines high filtration efficiency (guaranteed 96% against Aloxite 50 Test Dust) with long life. Unaffected by moisture, non-cracking, and resistant to fungal growth, it is ideal for the collection of sooty or tarry deposits, **without any danger of fibre migration**. Vokes Super-Vee, which is fully interchangeable with other filters of its type, is already widely used in applications such as paint finishing plant, chemical laboratories, textile plant, distilleries and heating and ventilating installations. Write for details of how it can give you high filtration efficiency at lowest possible cost.

Comprehensive literature concerning all Vokes filters is available on request from the Sole Agents.

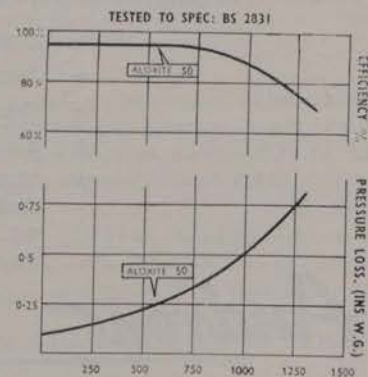

Dust Load on Filter (Grms.).

Filter Medium is Flame Resistant to BSS 476.

# VOKES

\*Registered Trade Name

## THE LEINSTER ENGINEERING CO. LTD.

158-159 CHURCH STREET, DUBLIN.

Phone 77093/4

Thirteen



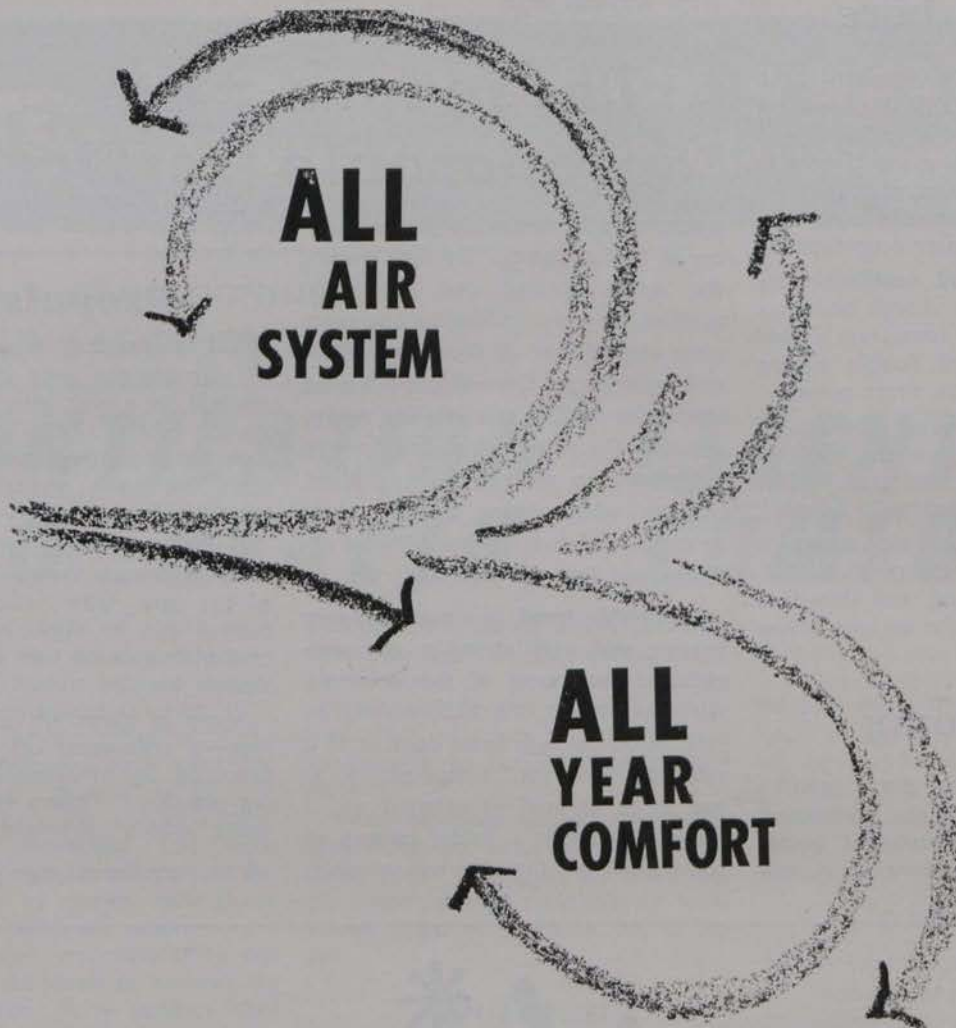

Simply and simultaneously the Andrew all air single duct system supplies the desired degree of heating during cold weather together with filtered air ventilation of the entire building. In the summer, when heating is not required, the same system is used for ventilation only. All this at a fraction more than the cost of a direct heating system which merely heats in cold weather and at no time contributes to ventilation.

**Features of the ANDREW HIGH VELOCITY SINGLE DUCT AIR CONDITIONING SYSTEM**

- ★ One system for heating-with-ventilation.
  - ★ Summer ventilation by the same system.
  - ★ Central conditioning plant.
  - ★ Suitable for new or existing buildings.
  - ★ Virtually noise, draught and dust free.
- Cost? Just a fraction more than that of central heating. May we tell you more? For illustrated literature, including technical data of a typical installation, apply:

*Andrew*

**ANDREW AIR CONDITIONING LIMITED**

POWELL DUFFRYN HOUSE, 19 BERKELEY STREET, LONDON, W.1.  
MILL STREET WEST, BELFAST, 13.

Representatives in Eire: TEDCASTLE, McCORMICK & CO. LTD., D'OLIER ST., DUBLIN



from page thirteen

purpose designed heater battery or heat exchange through which the air is fan blown.

## Experience

**AND** remember—In the summer, the fan can operate to move unheated air throughout rooms.

All will have experience of over-bearing heat on a sunny day when standing still in a roadway. All will remember the refreshing coolness of the descent of a hill on a bike in the same conditions—yet the air temperatures are the same. Moving air has a cooling effect in summer even if it is at the same temperature as still air.

This summer use of a heating-ventilating plant is now available to all. It may well set the pattern of things to come.

# INSULATION AN ESSENTIAL FUNCTIONAL REQUIREMENT

**A**CCCEPTANCE of thermal insulation as an essential functional requirement of modern building and plumbing services is quickly gaining ground.

In a great number of fields thermal insulation aims to prevent all unwanted heat losses.

The simple principles are quickly grasped as soon as the means by which expensive and discomforting heat losses occur, are understood.

Heat "flows" always from a substance at higher temperature to one at a lower

temperature. The heat always flows from the hotter to the cooler substance—hence the commonly used expression, "Heat Loss." Furthermore, this heat loss will continue until both substances are at the same temperature. That is, unless some form of thermal insulation is applied to insulate the bodies of differing temperatures and so intercept and minimise the heat transfer losses.

**Heat Transfer** may be by any one of the following or it may be by combination of two or more of them.

**Conduction.**—Heat flows through or along a material or from one material to another in contact with it.

Conduction heat transfer increases as the temperature difference throughout the length of material increases or as the temperature difference between the two materials in contact increases.

**Convection.**—This form of heat

*continued overleaf*



## MAKE YOURS AN AIR-CONDITIONED KITCHEN

Install a new "Gold Star" Ductless Hood!

No more cooking smells in any part of your home. Here is a new cooker canopy; installed in under twenty minutes with two screws. Two wonderful filters; one absorbs grease and smoke, the second of activated charcoal eliminates odours, stale air and steam. Requires no pipes, ducts or holes in the wall.

NO HEAT LOSS; NO DRAUGHTS; COMPLETELY ELIMINATES COOKING SMELLS, GREASE AND FUMES; INSTALL IN A FLAT OR HOUSE—TAKE IT, WHEN YOU MOVE! KEEPS KITCHENS FRESH, CLEAN AND PLEASANT:

PRICE—24", £28-13-0; 36", £34-14-0, OR EASY TERMS. FROM ANY E.S.B. OR GAS COMPANY SHOWROOM OR ENQUIRE FROM YOUR LOCAL DEALER.

### GOLD STAR DUCTLESS HOOD

Write for further details and leaflets to the sole distributors.

**W. & L. CROWE LTD.**

EAST WALL, DUBLIN — TELEPHONE: 43101

*The Irish Plumber and Heating Contractor.*

*from previous page*

transfer occurs in liquids and gases. It involves circulatory movement of heated particles of matter within the material heated. As water or air is heated it expands and becomes less heavy bulk for bulk than cooler water or air. The cooler heavier materials then fall by gravity and push the lighter, heated particles upward and away to expose more heated surface to colder, heat-extracting water or air.

Convection losses are increased as the temperature differences increase. They are also increased by air movement. Conversely, they will be reduced as temperature differences level off or as air or water becomes less mobile.

### Heat emitted

**Radiation.**—In this case heat is emitted from a hot body to a colder one in the form of heat energy wave motions. In many respects this is similar to light transmission. Radiant heat does not appreciably warm air through which it passes but it will warm any solid body which intercepts its ray. Radiant heat moves in straight lines. It can be "bent" or deflected by reflecting devices, but it is important to realise that to receive radiant heat a body needs to be in view of the radiant heat emitting source.

**The purpose of thermal insulation** now becomes clear. It is to so enclose

a heated body, or a substance, at higher temperature than its surroundings (e.g., cold water surrounded by air at 32 degrees F.) in such a way as to prevent or markedly reduce heat loss from the substance within to the colder substance without. This applies particularly to prevention of heat loss from hot water pipes, boilers, store vessels, etc., as well as to "cold" water fittings. In the case of thermal insulation in structure preventing loss of heat from inside the building to colder outside air, the principle remains the same. In summer, when the structural insulation helps to keep the building cool by reducing the solar radiation heat gain, the principle still holds good except that in this instance the insulation is protecting the heat absorbing substance rather than the heat emitting sun.

### Properties

**The properties of thermal insulating materials vary.**—It is worthwhile knowing some of these properties in order that a reasoned choice of material can be made for different specific applications.

**Low thermal conductivity.**—This means that the material itself will not be a good conductor of heat. Therefore there will be less risk of the insulation quickly getting as hot as the pipe or material it is applied to protect and thus loose heat quicker than the smaller surface area of the unprotected pipe would.

**Porosity.**—The value of still air as a thermal insulator has already been referred to. Thermal insulating materials will make use of this known heat insulating property of still air and will therefore be compounded of cellular material to provide multitudes of cells of still, trapped air.

**Fire resistance.**—The material should be incombustible or at least offer considerable resistance to fire spread.

**Weight.**—Though not of prime importance to pipework insulation, this is worthy of consideration in cases where no great extra superimposed load is desirable, the ease of applying thermal insulation above top floor ceilings for example.

**Resistance to fugal attack.**—This is a desirable property of insulation for situations liable to damp.

**Resistance to insect attack.**—Worth considering in all cases, when moths have been known to attack and ruin hair-felt insulation.

**Resistance to moisture absorption.**—This is an important property where insulation is to be chosen for damp situations, e.g., outdoors, or in steamy kitchens.

**Surface finishes.**—Ready-to-fit materials are much preferred for pipe runs as being easier to apply. A neat uniform finish is assured and the ease with which the insulation can be removed and refixed in repair work are other advantages of this type of insulating material.

*In conjunction with this special survey on air conditioning, refrigeration and insulation materials, we review products from the leading manufacturers' ranges.*

**A** VENTILATION system which has been designed as one of the Terrain systems now being produced by A.B. Plastics Ltd. is based on the use of the Darvic and Corvic brands of P.V.C. supplied by Imperial Chemical Industries Ltd. The Terrain ventilation system is believed to be the first to employ patented extruded sections, and cold solvent welding as the principal method of fabrication.

The P.V.C. sheet and extrusion used in the Terrain ventilation system have an outstanding resistance to most strong acids or alkalis, especially at temperatures up to 140F. This makes

*continued page eighteen*

# Factory Roof INSULATION

Enquiries Invited

W. H. HEYWOOD & CO.  
(Ireland) LTD.

63 Upper O'Connell Street, Dublin, 1.

Telephone: 44237.

**Specialists  
in the supply  
and fixing  
of thermal  
insulation  
to factory  
roofs**

# GREENWOOD'S 'LLOYDAIRE' REGISTERS AND GRILLES

EXTRUDED ALUMINIUM — CLEAR LACQUER FINISH

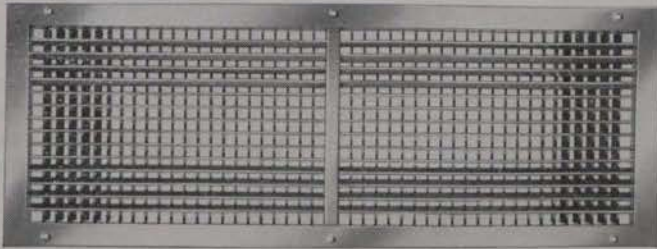

L.55 36" x 12" Double-deflection supply grille—horizontal face blades and vertical rear blades.

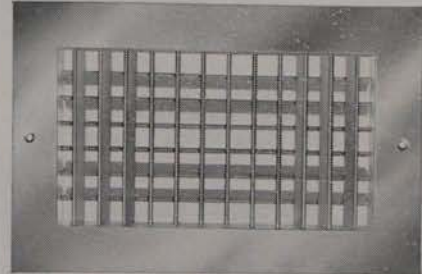

L.64 12" x 6" Double-deflection supply grille—vertical face blades and horizontal rear blades.

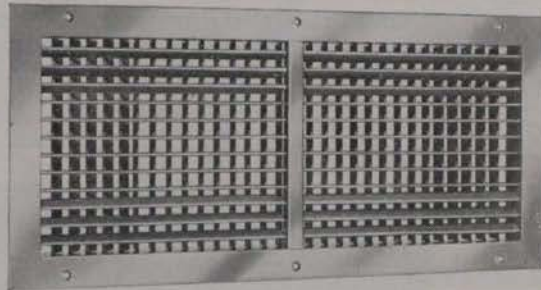

L.55 24" x 10" Double-deflection supply grille—horizontal face blades and vertical rear blades.

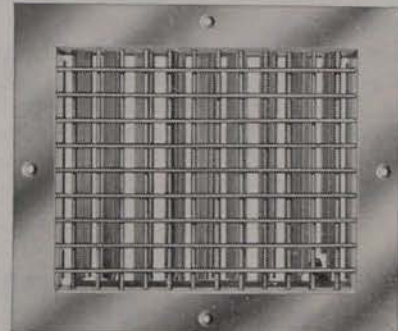

L.557 12" x 10" Double-deflection supply register — horizontal face blades, vertical rear blades—opposed blade damper.

"Greenwood's Lloydairé" Registers and Grilles provide a highly flexible means of air distribution for modern heating and air conditioning schemes in commercial and industrial buildings.

Supplied as standard in brushed extruded aluminium with clear lacquer coated finish, "Greenwood's Lloydairé" Registers and Grilles are available in a fully comprehensive range of sizes and arrangements to suit current architectural and engineering specifications.

Combining elegance with efficiency, they are light, robust and strongly resistant to corrosion.

Write today for literature on Greenwood's "Lloydairé" range of Registers and Grilles.

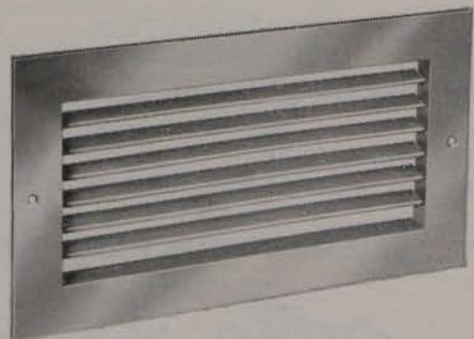

L.70 12" x 6" Return Air Grille—horizontal face blades set straight.

## Greenwood Airvac *ventilation*

GREENWOOD'S AND AIRVAC VENTILATING COMPANY LTD

ESTABLISHED 1879

PATENTEES, DESIGNERS AND MANUFACTURERS OF  
NATURAL AND MECHANICAL VENTILATING EQUIPMENT



BEACON HOUSE, KINGSWAY, LONDON, W.C.2.  
CHANCERY 8135 (4 lines). 'Grams: 'AIRVAC', LONDON

Agents and Distributors for Registers & Grilles

TECHNICAL SALES COMPANY 79 Lower Leeson Street, Dublin. Telephone: 61662.

*The Irish Plumber and Heating Contractor.*

*from page sixteen*

the P.V.C. an ideal material for chemical fume extraction ducting for Laboratories and Process Plants.

The P.V.C. used in this Terrain system has a specific gravity of 1.44 compared with Aluminum 2.7 and Galvanised Steel 7.8 approximately. Information is available from Unidare Ltd., Finglas, Dublin.

Picture shows Terrain system of heating and ventilating ducting made from Darvic I.C.I. rigid P.V.C. sheet by A.B. Plastics Limited, designed and installed in a new plant by Carrier Engineering Co. Ltd.

★ ★ ★



TURBOMASTER is a packaged water cooling system. This is a single-stage turbo compressor for refrigerants, complete with shell and tube condenser and evaporator, factory assembled and tested and delivered on two base plates.

Also available is the Embassy free-

standing self-contained air conditioning unit for use in hotels and restaurants, etc. The cooling unit for this incorporates a York hermetically sealed gas-cooled compressor, and the whole unit is factory sealed before dispatch. The manufacturers are York Shipley Ltd.

INDOLA industrial fans are used for exhausting foul air, harmful vapours, fumes of gases. Powerful totally enclosed induction type motor of robust construction makes this fan type suitable for use under severe conditions. All motors have been specifically designed for fan duties.

The propellers have been constructed according to the latest aero-dynamic principles. A complete line of industrial fans is offered.

To solve ventilating problems for any room Indola have also brought out a series of adjustable window fans ranging from 6" to 10" blade diameter. Of a unique design they feature a spring loaded outsider cover, adjustable through an arc of 90 degrees. The fan body on the inside of the room is attached to a moveable arm which can be similarly adjusted.

The Irish representatives for Indola of Rijswijk, Holland, are the Technical Equipment Co. Ltd., 2 Fitzwilliam Place, Dublin.

★ ★ ★

EXTENDING the range of "Heat Throw" unit heaters, Keith Blackman now have available vertically

*continued page twenty*

# STELETEX INSULATION

- REDUCES HEATING COSTS
- PREVENTS CONDENSATION
- INCREASES LIGHT REFLECTION

Many leading industrial firms throughout Ireland already enjoy the advantages of Steletex **FIRE-RESISTING** factory roof insulation.

**NOW AVAILABLE WITH WASHABLE PLASTIC FACE**



*Write for Technical Literature to-day*

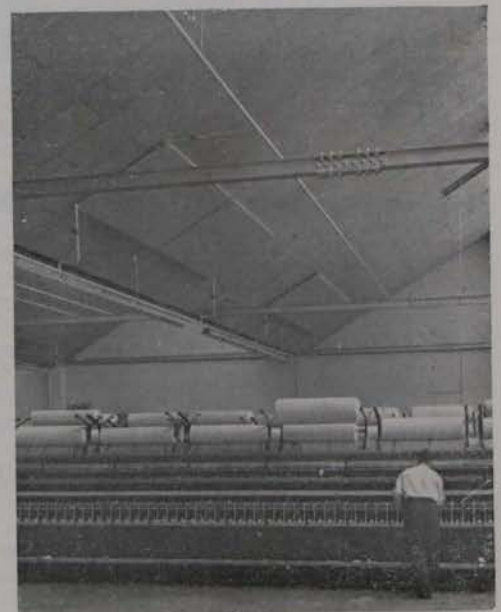

## GYPSUM INDUSTRIES LTD.

SOUTH RICHMOND PLACE, DUBLIN, 2.

TELEPHONE 53624

# GAIN 6 WAYS

## better thermal insulation value with DARLINGTON 85% SUPER-MAGNESIA

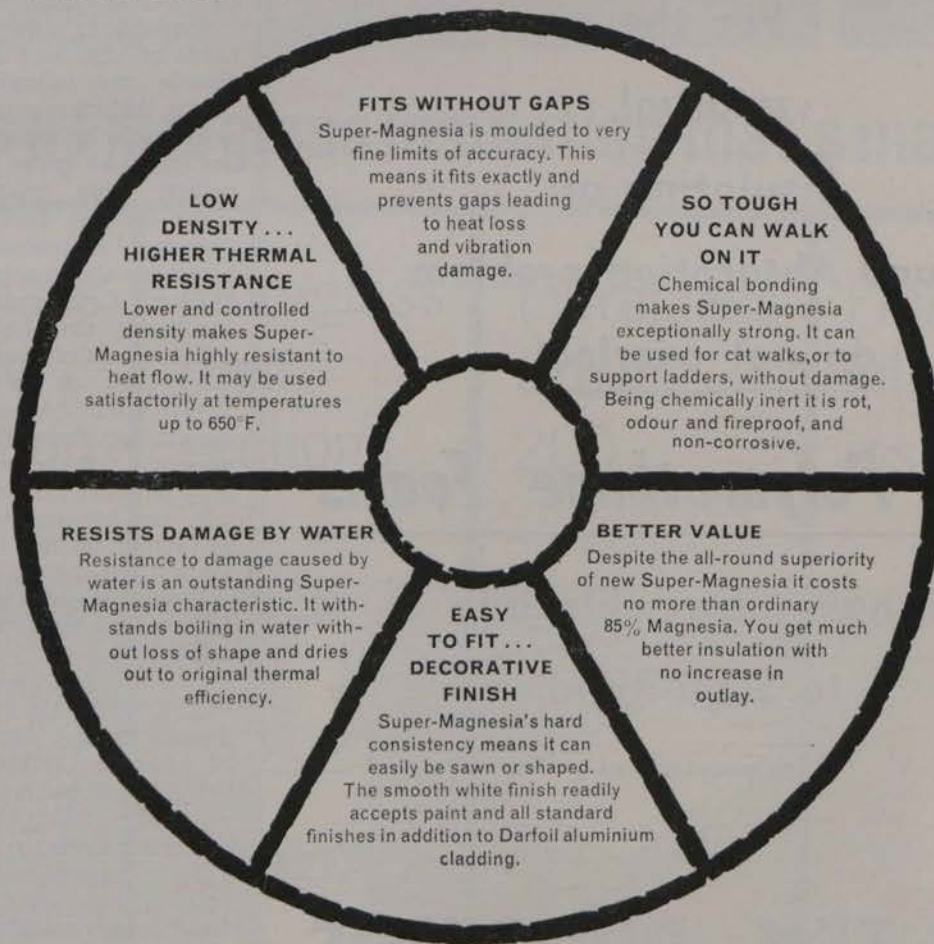

**AVAILABLE IN ALL STANDARD SIZES NOW!**

**THE CHEMICAL AND INSULATING CO. LTD.**

DARLINGTON, CO. DURHAM

Telephone: Darlington 3547

*A member of the  
DARLINGTON CHEMICALS LTD.  
Group of Companies*

Agents for Eire: GOODBODY LTD., IBEX WORKS, DUN LAOGHAIRE, DUBLIN

from page eighteen

mounted unit heaters with down flow air stream suitable for steam or hot water, arranged with single or three phase supply. These are a development of the horizontally mounted diagonal air flow type.

Heat outputs range up to 158,000 B.t.u./hr. with air discharge temperatures from 60 to 190 degrees F., and all Heat Throw units are held in stock for dispatch within seven days.

Among recent introductions are the range of Aristocrat centrifugal fans with forward curved blades designed

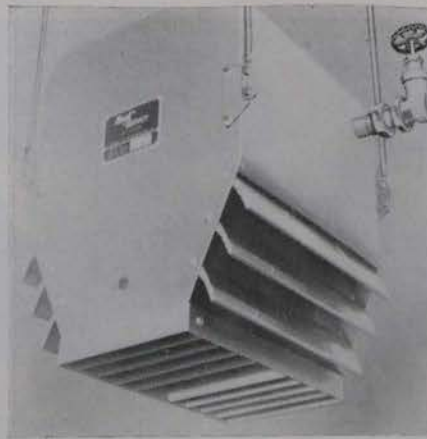

for general ventilation, heating, ventilating and air conditioning applications. Available in five sizes for volumes up to 6,000 c.f.m., at static pressures up to 3.5 in. w.g.

Illustrated is the vertical mounting "Heat Throw" unit heater from Keith Blackman Ltd., 20 Harcourt St., Dublin.

★ ★ ★

GREENWOOD AIRVAC are introducing a new range of commercial registers and grilles under the trade name of Greenwood's Lloydair. Manufactured in extruded aluminium with clear lacquer coating, Greenwood's Lloydair registers and grilles provide a highly flexible means of air distribution for modern heating and air conditioning systems in commercial and industrial buildings.

Available in a fully comprehensive range of sizes and deflections which include the following:—Single and double deflection supply grilles; single and double deflection supply registers and return air grilles and registers; the register units incorporate opposed blade dampers having a single cam operator for controlling all damper blades simultaneously.

From Greenwood's and Airvac Ventilating Co. Ltd. Irish agent: Technical Sales Company.

★ ★ ★

THE BREEZA multi-fan roof unit consists of four 12" or four 15" diameter 1,400 r.p.m. Breeza heavy-duty propeller fans mounted horizontally and blowing through automatic non-return shutters fixed on the four vertical sides of the unit.

From London Fan & Motor Co. Ltd., Sandycombe Road, Richmond, Surrey.

★ ★ ★

ANDREW Air Conditioning Ltd., Powell Duffryn House, 19 Berkeley St., London, W.1., have introduced the "Dynaflow" centrifugal exhaust powered roof unit—a completely self-contained extract system.

Main features of this unit are as follows: Low speed balanced centrifugal backward curved non-overloading fan impeller with low tipped speed and consequent low noise level; a rugged fan box providing "scroll effect" for maximum efficiency, plus rigid motor and bearing mountings for minimum vibration and air noise, the whole insulated from the bare structure by anti-vibration mountings.

There is a standard medium speed totally enclosed motor, fitted out of the main airstream and insulated from

**For the  
unusual  
Insulating or  
Sound Absorption problem  
do not overlook**

***Cortx Polyurethane Foams***

**ranging from Flexible  
to Semi-Rigid**

as manufactured

by

**COR-TEX PROOFERS**

**Limited,**

**KINSALE ROAD,  
CORK**

# WHATEVER THE JOB..

Tanks

Pipes

Boilers

Ducting

there's a Fibreglass insulation that's made for it

Fibreglass Flexible insulation

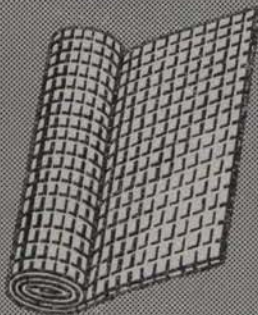

Fibreglass rigid sections



Fibreglass Crown 200

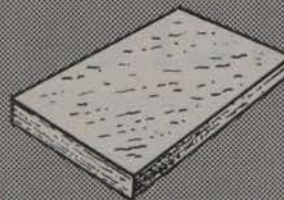

Fibreglass Filmed insulation

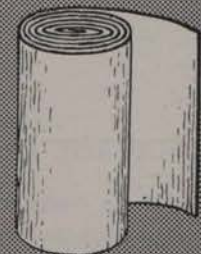

Fibreglass has a very high insulation value. It is simple to handle, fire-safe, vermin and rot-proof. You can get these forms of insulation delivered in the quantities you want when you want them.

**MONSELL MITCHELL & CO. LTD**

*Sole distributors of Fibreglass heat insulation products in the Republic of Ireland.*

Published by ARROW@TU Dublin, 1962

**Fibreglass Limited**

**21 MERRION SQUARE DUBLIN**

*Twenty-one*



from page twenty

the fan by premium long-life "V" belts, and sealed long-life fan bearings with means of recharging with grease "in situ" for minimum maintenance and servicing. The Irish representatives are Tedcastle, McCormick & Co. Ltd., D'Olier St., Dublin.

★ ★ ★

COLT Ventilation Ltd., 5 Newcourt Avenue, Bray, Co. Wicklow, have just introduced an entirely new and versatile unit to their range—the Colt powered "Airchanger." It is primarily intended for laundrettes, restaurants and canteens where comfortable draught-free ventilation is required, winter and summer.

This is a complete and self-contained ventilating unit driven by only one fan, which nevertheless produces simultaneous air input and air extraction, always in perfect equilibrium at the rate of 70,000 c.f.h. in each direction. The variable air projector through which the incoming air is delivered can be set to direct the air current to any part or parts of the area to be ventilated.

★ ★ ★

THE RENOVAIR is one of the latest additions to the comprehensive range of Vokes air filters, and is ideal

for use in places where people congregate. Switched on, it completely clears tobacco smoke and other air-borne contaminants from the atmosphere within a few minutes. Because the Vokes Absolute filter in the Renovair cleans air which is then recirculated, heat loss is eliminated.

Also available is the Vokes Autoroll Mk 11. The 125 ft. length of fire resistant filter medium is automatically fed from a top spool across the air flow onto a lower spool. It gives approximately 14 per cent. greater capacity than the original Autoroll—with no loss of performance. The manufacturers are Vokes Ltd., Henley Park, Guildford, Surrey, represented in Ireland by the Leinster Engineering Co., 158-159 Church St., Dublin.

★ ★ ★

A COMPACT packaged air cooling unit, which is one of a new range with capacities of 6, 9, 15, and 23 tons refrigeration, is available from the Lightfoot Refrigeration Co. (Ireland) Ltd.

★ ★ ★

TEN MAIN product ranges now marketed in Britain by Chrysler Air-

PRODUCT REVIEW Continued  
page thirty-three

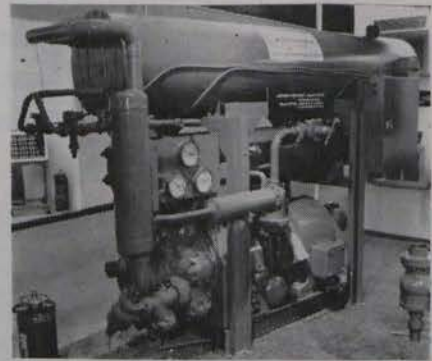

temp Ltd., an associate company of Chrysler International S.A., are now available throughout Ireland for the first time from Everton Engineering Ltd., Newtownabbey, Co. Antrim.

The ranges include compact window and wall mounted Room Air Conditioning Units with capacities from 8,000 B.t.u./hr. to 28,000 B.t.u./hr.; Radical type packaged liquid chillers 35-100 h.p. (see illustration); air handling units, 200 C.F.M.-32,000 C.F.M.; packaged air conditioners, hermetic and serviceable sealed compressors air and water cooled, 3-30 h.p.; and radical type compressor sets for refrigeration applications, 15-125 h.p.

# BREAKTHROUGH!

At last the Insulation with the Waterproof Cover!

# 'THERMALAINE'

FOR THE INSULATION OF PIPING IN DUCTS, ROOF SPACES, WALLCHASES, OUTDOORS.

Consulting Engineers who specify it can be sure that come dampness or flood the insulation will remain good.

Contracting Plumbing and Central Heating Engineers who use it will get a first-class waterproofed insulation at low prices that can be applied with speed, eliminating one stage of the usual lagging process, thereby cutting labour costs to the absolute minimum.

Clients will like it because it is clean and easy to handle, being supplied to fit the Bore of the Piping being covered, therefore eliminating dirt around the site.

Workmen will like it because the waterproof cover does away with the discomfort that goes with the handling of the usual insulating materials.

★ Considering this material does away with one stage of the lagging process, the cost is remarkably low and compares very favourably with other popular materials.

**McAULEY & CUNNINGHAM**

9 Pearse Buildings, 23-25 Pearse Street, Dublin. Telephone 74652.

Agent: JOHN F. MANGAN & CO., 105B, Morehampton Road, Donnybrook, Dublin.

# The **LYNX** now in Colour

- PINK**
- PRIMROSE**
- TURQUOISE**
- GREEN**
- WHITE**



Shires LYNX in black Duranite is already the most popular cistern for new installations and replacement. Now a new development in manufacturing technique makes it possible to produce the low-level Lynx in coloured polypropylene which has the strength and long-lasting qualities of Duranite. The famous LYNX design and advantages are unchanged.

- Attractive lines*
- Hygienic and easy to clean*
- Quiet, flush-at-a-touch action.*
- Unbreakable, non-corroding siphon mechanism*
- Concealed fixing*
- Suitable for hard or soft water areas*
- Conforms to BSS 1125 and Water Works specifications*
- Capacity 2 gallons*

**PLEASE WRITE FOR LEAFLET**

Other Shires' products are the Uni-Lynx close-coupled suite, seats, cistern fittings, and the Polyfloat cold water cistern float

*made by*  
**Shires**  
*of Guiseley For your convenience*

Available from all recognised builders' providers in the Republic  
**SHIRES (IRELAND) LIMITED**  
STANNAWAY DRIVE CRUMLIN DUBLIN

TGA 5 83D

Twenty-three

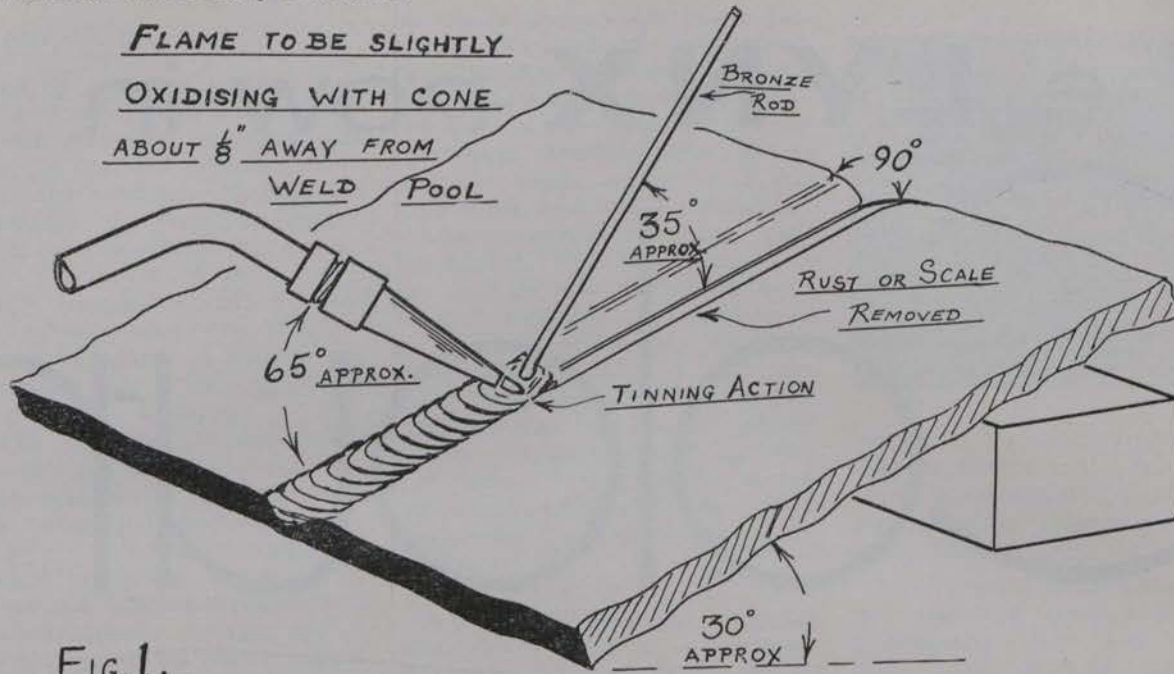

FIG. 1.

## Bronze welding of cast iron

from page seven

# CAST IRON: ITS REPAIR BY GAS WELDING

allow a job to be done in position and at a lower temperature, thereby reducing the risk of distortion.

In general, it can be taken that bronze welding will be the most suitable method for use by the average plumbing and heating contractor when faced with the repair of a cast-iron fitment. It also has the advantage that it will join other metals to the cast-iron if required, i.e., a copper tube to a malleable iron flange.

When preparing the job for bronze welding, it is usually necessary, unless the casting is light, to form a 90° Vee angle along the joint (Fig. 1), taking care that the root of the vee is preserved so that correct alignment of the job can be carried out. At the same time all traces of rust or dirt must be removed from the back and front of the weld area by cleaning with a wire brush. It is advisable also to round the corners of the Vee so as to eliminate sharp notches, and so give a better shear strength.

### Pre-heat

**I**F THE casting is large or of unusual shape it will be necessary

to pre-heat it uniformly in a fire or furnace to a point where it begins to assume a faint dull red colour, but if of small proportions general pre-heating with the blowpipe is all that is necessary.

Great care must be taken not to overheat, otherwise the bronze will not tin the metal properly, but will run away in small globules before the flame. The blowpipe nozzle size will have a bearing on this point, and it is usually accepted that a tip about two sizes smaller than that used for the fusion welding of a similar job is all that is necessary.

There are several types of bronze rods on the market, some produced for general use, others having characteristics making them suitable for specialised use—where exceptional strength is required. But any of the firms advertising welding equipment in this Journal will advise as to the best type if details of the job are sent to them.

A flux powder is also necessary, and again there are many brands available for this type of work. The

usual job method is for the heated end of the bronze rod to be dipped at regular intervals into the powder and then applied to the weld metal pool.

In setting up the job for welding, it will make things easier if the casting can be tilted at an angle so that the molten bronze will tend to build up into a stronger weld.

### Correct flame

**T**HE flame should be adjusted so as to give a very slight excess of oxygen. In the actual welding, the important thing is to "tin" the cast-iron.

This can only be done if the job is at the correct heat, and this can be tested by rubbing the bronze rod on the weld area. When correct temperature is reached the bronze will run forward with a "tinning" action. Once this occurs, the blowpipe can be moved forward in a side to side fashion so that a semi-circular series of waves are produced.

from previous page

## CAST IRON

When the weld is completed it must be allowed to cool slowly, away from draughts or cold air. If of large proportions the casting must be allowed to cool very slowly in a firebrick container, or surrounded by cinders.

When the work has cooled it can be cleaned up and excess flux removed, but it is not advisable to file or machine the weld, otherwise its strength is reduced. It can be said, with complete confidence, that a bronze-welded joint on cast-iron, when properly done, is in most cases of a higher tensile strength than the parent metal, and this, coupled with the fact that the weld can often be done without dismantling, makes this method of repairing broken castings, a "must" for many contractors.

### Fusion welding

**I**F, in repairs to cast-iron, a perfect colour match and smooth finish is required, we have no alternative to fusion welding. This, however, usually entails complete dismantling and preparation of the weld area by bevelling to an angle of about  $80^\circ$ . The face and back of the weld should also be wire brushed to remove all trace of sand, grit, grease, etc.

As the ductility of grey cast-iron is low, local heating of the joint will, almost certainly, cause other fractures to occur, so that pre-heating to a temperature of about  $600^\circ\text{C}$  is necessary.

It is essential that the casting be thoroughly heat-soaked and that the area in the vicinity of the weld be kept at this temperature during the welding operation, and afterwards very slowly cooled, otherwise a very hard and brittle white cast-iron will form and cause endless trouble. With difficult castings such as boiler door frames (Fig. 2), indirect pre-heating will be necessary so as to provide parallel thermal expansion in all areas of the frame, and eliminate stresses liable to cause cracking.

It will not be necessary to maintain the same degree of heat in all parts of the frame and the sketch indicates the method to be adopted.

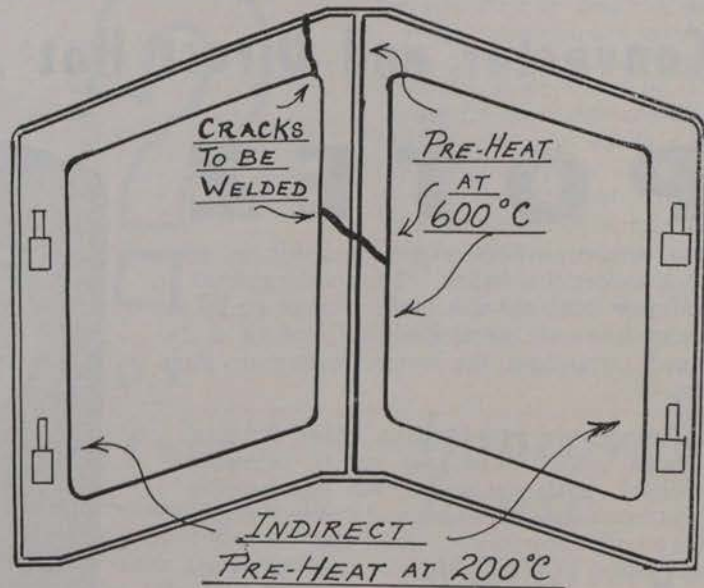

**FIG. 2 FRACTURED BOILER DOOR FRAME**

### Flame control

**A NEUTRAL** flame is necessary; exactly the same as that used in welding mild steel, etc., but care must be taken to prevent the white inner cone from touching the molten metal—it should be kept about  $\frac{1}{8}$ " from the pool—otherwise carbon may be taken up and a hard brittle weld result.

The blowpipe tip should be kept at an angle of  $65^\circ$  approximately so that the molten metal is not blown over the weld edge. The flame is played around the cast-iron filler rod which is melted in the pool and not stirred or puddled about, the technique used being the leftward or forward method explained in a previous article.

### Flux

**T**HE use of a flux is almost essential to assist the flow of the molten metal and prevent oxidization, but it should be applied sparingly by dipping the heated rod in the tin and then applying to the weld. There are several excellent brands of flux available for this type of work.

When the weld is completed all traces of oxide or slag can be removed, while hot, by scraping or wire brushing. If, however, the metal is

allowed to cool first, slag removal will prove most difficult.

The author has carried out repairs to cast-iron fittings by bronze-welding and by fusion welding, and in the light of experience would recommend bronze-welding for most repair work where the casting is not exposed to great heat.



● Pictured here is the "RAD 66", which was recently released for production by the Sealed Motor Construction Co. Ltd. (Full report in May last's Trade Topics.

## Convactor and Direct Hot Air Heating Units

—By

# P O T E Z

These attractive heaters are available in three models as detailed below. They are operated on paraffin or domestic diesel oil. Fumes go up the chimney and only pure, beautiful, hot air is distributed throughout the home, factory or glass-house.

- Model No. 331. Output 17,280 B.T.U./h. Heated space up to 4,945 cu. ft. (corrected volume). Extra flat model. New type patented heat exchanger. Fuel tank and draught regulating shutter incorporated. Price £28.
- Model No. 631. Output 24,640 B.T.U./h. Heated space up to 7,770 cu. ft. (corrected volume). Price £38.
- Model No. 7R1 (as illustrated). Heated space up to 12,713 cu. ft. (corrected volume). Price £48-5-0.



Model No.

**7R1**

Output 37,440 B.T.U./h.

Distributors:

**THE HOUSE OF ROWAN**

M. Rowan & Co. Ltd., 51-52 Capel St., and 1-2 Westmoreland Street, Dublin. Phone 41891 (10 lines).

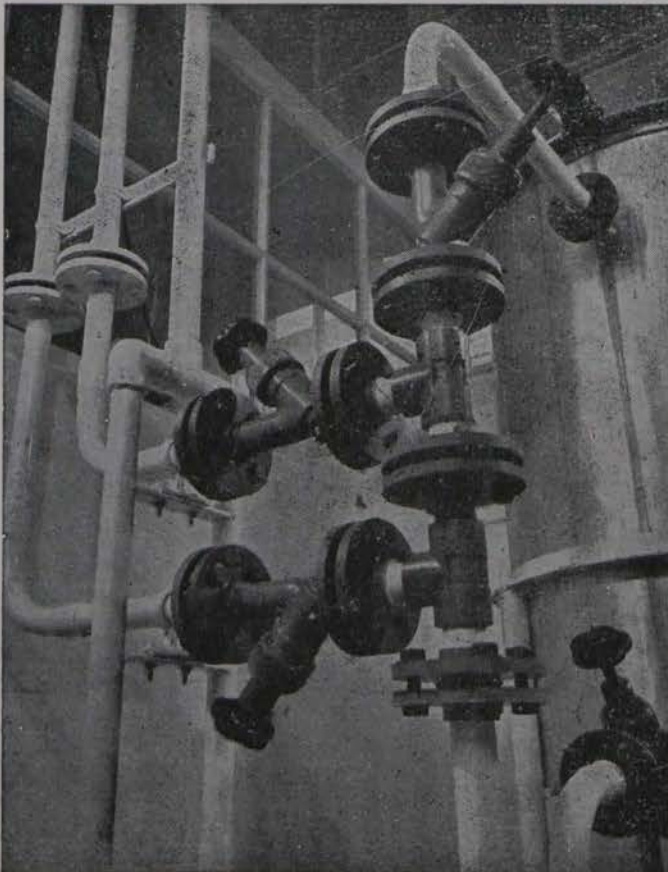

## We chose Wavin PVC...

### AT CASTLEFORBES WORKS

Castleforbes Works had a problem! A highly corrosive chemical, used in their modern manufacturing process in Dublin made very short work of conventional pipes. This could mean frequent renewal of the pipe-lines, with consequent loss of production and the risk of dangerous bursts—but they chose Wavin PVC because Wavin PVC Pipes are immune to chemical attack. They are also inexpensive and easy to instal, with a complete range of PVC fittings. And they solved their problem efficiently and cheaply.

If you have a problem in pipework, why not consult Wavin—the pioneers of PVC in Ireland.

# wavin

WAVIN PIPES LIMITED  
CIAN PARK, DRUMCONDRA, DUBLIN 9  
Telephone : 48000 or 373614/6

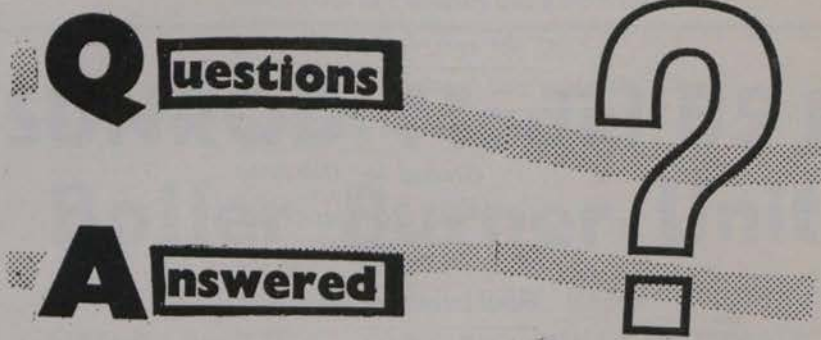

## Flow pipe was packed tight

I am enclosing a sample of what I think is a compound of lime and iron. This was taken from the flow pipe in a domestic hot water supply system fitted only five months ago. The system developed a terrifying banging and subsequent drain down and inspection revealed the flow pipe to be packed tight with this compound. The actual connections to boiler and cylinder were fully clear, so was the return pipe.

The boiler is of copper and fitted

in a "Truburn" cooker. The distance to cylinder from boiler is only about 3ft. The water comes from a shallow well about 10ft. deep in scaly rock. It could have a good percentage of iron since there is an old iron mine only a few miles away.

Five months seems a short time for this trouble to have developed. Can you suggest cause and also give some idea as to how much a water softener would cost?

**THE LOOSE**, granular deposit referred to above has been tested. It shows no traces of iron. It appears to consist mainly of carbonate, presumably calcium carbonate. This may have derived from the possibly ferruginous limestone which seems to underly the area of Co. Cavan. The deposit is typical of that likely to be found in strongly overheated waters derived from limestone beds.

A little more information concerning the routing of the circulatory pipe-work, its diameters and material, would perhaps have helped to determine the cause. From information given it might be due to any one, or combination of the following:—

1.—Local overheating of the water. This could be due to sluggish circulation. This is likely when the vertical distance from centre of boiler to centre of cylinder is very small for then the circulating pressure would be commensurately small and the convective movement of water slow—especially in undersized pipes. Slow moving water gains more heat by longer contact with the hot boiler surfaces. Furr precipitation increases rapidly as temperature of water in-

creases, hence the suggestion of local overheating as a possible cause.

2.—Although not, for one moment, implying careless workmanship in this instance, such local blockages have been known to be due to strands of joint hemp criss-crossing the pipe bore at the joint. Such a mesh acts as an effective filter which strains out, and retains all solidified particles of "furr" as they are precipitated by heating the water. This explains the location of blockage in one part of the system in such cases. Normally, one would expect to find a more general dispersal of "furr" throughout a properly sized and unobstructed circulation.

3.—Overheating generally. Since the boiler is in a cooker and this presumably is kept going day and night, is it not possible that the water is not being drawn upon enough to keep its temperature down to a desirable 140°F? This is one of the common snags in "double duty" appliances of this kind. If this is the case, why not consider taking of a radiator to absorb some of the boiler heat generation and so reduce the stored hot water temperature? The radiator could be shut off in event

of need to put all boiler output to the hot store as occasion demanded.

Water softeners are now available in so many styles and capacities that to offer a price would be misleading. Querist is advised to consult his local stockist where he should find one to suit his purpose for around £70, and of such capacity that it might suffice for a household of four for two weeks before needing regeneration. But note, capacity of softener, hence its price, depends upon daily water consumption and its total hardness figure.

★ ★ ★

## Improved house warming system

Articles in your Journal have prompted me to consider an improved house warming system before next winter. I cannot quite decide which might be best but am inclined to favour the warm air system. The only snag here appears to be that this sort of system does not heat hot water for domestic use and so extra equipment becomes necessary. Your comments would be appreciated.

**WE ARE** glad that querist, together with many other readers who have sent appreciative notices, find helpful material within the pages of the Contractor.

So far as space heating, especially of the home, is concerned, several comprehensive Special Surveys have been compiled by our Technical Contributors solely with the aim of informing on the latest ideas in this field. Past issues of the Contractor have carried specific articles on the particular installation and design problems involved. As recently as the March issue, Mr. H. M. S. Miller made a splendid contribution to this field of information with his comprehensive appraisal of heating methods, fuels, and anticipated performances.

**House Warming by Warm Air** has many advantages from the physiological comfort, and the economic usage points of view. These were clearly outlined in Mr. Miller's article referred to above. Excellent as room heating convector stoves are,

*continued opposite page*

*Twenty-seven*

they are local appliances and as such warm only the room in which they are fitted. Earlier designs of stoves provided with duct connections to take some warm air to another room have been largely discontinued for good technical reasons.

**Whole House Warming by fan assisted warm air** circulating is now possible owing to the foresight of many manufacturers who have designed and marketed equipment to meet this popular growing need for quick, economic space heating method.

Warm air heating "machines," comprising air intake duct, prime heater, fan and dampered outlet grills, are available at competitive prices to deliver up to 45,000 B.t.u.'s per hour—adequate for full space heating of all normal domestic dwellings.

## Competitor

**Selective Warm Air Heating** by similar "machines" of smaller capacity are proving a serious competitor to all other forms of domestic warming. The economy of operation which these offer, and the convenience with which they may be clock controlled to user's pre-set need are much appreciated advantages over other forms of house warming.

One such "selective" heating plant generates up to about 17,000 B.t.u.'s per hour. Insufficient as this is for whole house warming, it is more than adequate to heat the main living area, the dining-room, and perhaps one other room or hall. The economy of the "machine" lies in its being adjustable to direct warmth selectively to the room most needing it, or to adjust for flow to other rooms when the main heat load is satisfied.

The relatively small space occupied by these appliances is another factor in their favour. Absence of circulatory pipework and wall radiators is another.

## Circulated

**Fan assisted convectors** in attractive cabinet designs are now available for small bore force circulated systems. The convectors have high efficiency finned heat exchangers fed by heating water from a boiler in this instance. Their high output enables only one such appliance to be used where perhaps several radiators of conventional gravity air convection would be needed to give the same heat emission.

*Each month this column will solve some  
of the everyday problems of  
the plumbing and heating engineer when  
our consultants deal with queries  
directed to "Questions  
Answered." All queries will  
be replied to and the  
most interesting published.*

Querist might consult his stockist and examine appliances of this kind as made by Allied Iron Founders, F. H. Biddle Ltd., "Copperad" of Slough, Bucks, and others. Using these, he could obtain quick warm air heating, and summer fan running for cooling air movement, even on a conventional small bore job which, of course, would provide him with D.H.W. as well.

**Warm air "machines"** are made as integral units of heater, fan, and duct inlet-outlets to burn gas and in this form they are proving very popular because the fluing problem is quite a small one. Electrically heated units are also available and these, requiring no flue at all, can be fitted under the stairs if need be—quite out of the way.

## Attainable

**Warm Air Heating and D.H.W.** is now attainable in the true warm air "machine" form. This new development by one or two manufacturers is to be applauded for it removes the sometimes quoted drawback of warm air heating means provision of a separate D.H.W. system.

**The SUGG warm air heating "machines"** are now available with a Radiation Group Sales "Cirulyne" hot water heater incorporated within the casing of the air heating equipment. This provides a convenient, economically operated, "packaged" complete house warming and D.H.W. system for gas fuel operation. Prices are keen, operating and installation costs are low. Querist is recommended to have a close look at this new equipment.

## Any Fuel

**The Biddle Warmflo** offers a similar warm air heating and D.H.W. unit but for operation on any fuel from an ordinary boiler. Thus, even where gas fuel is unobtainable, equip-

ment is now available for warm air heating but without the bother of separate D.H.W. provision.

The Warmflo unit comprises copper D.H.W. cylinder, **gravity** H.W. circulated heat exchanger to warm air (NOTE no circulator needed), a silent air moving fan, and duct provision to three rooms.

Its D.H.W. heating rating is 10,000 B.t.u. per hour, giving about 10 gallons of hot water per hour, or a three-hour recovery period for discharged hot water cylinder. The air heat exchanger has an emission of some 23,000 B.t.u.'s—adequate for the economic selective warming to good heating standards.

## Circulation

In summer the air moving fan can be used for cooling air circulation.

The total rating of the Warmflo being in the order of 33,000 B.t.u.'s, it will operate quite well off a comparatively low rating boiler of querist's own choice.

This is a unique piece of equipment offering flexibility of installation and operation. It offers wide choice of fuel usage, takes but 2ft. x 2ft. floor space (it could be fitted in airing cupboard in place of D.H.W. cylinder, or where the cylinder would normally be). It uses no pumps or other ancillary items.

*QUESTIONS ANSWERED are continued on page thirty-six*

## THEIR 1,000TH ISSUE

● The July 1962 issue of "The Plumber and Journal of Heating" will be the 1,000th published since it was established in February, 1879. Publication has been continuous throughout this period including the two world wars. The 1,000th issue will contain special articles reviewing the various aspects of plumbing and heating.

# 'SUNROD' Model B5 Pressure Jet Boiler Burner Unit

RATING 60/80,000 B.T.H.U. PER HOUR. CAMRON BURNER FITTED. EFFICIENCY OVER 80%. FULLY AUTOMATIC OPERATION. OUTPUT REMARKABLY HIGH IN RELATION TO SIZE. ALL COMPONENTS FULLY GUARANTEED. FULL AFTER SALES MAINTENANCE SERVICE. DELIVERY EX STOCK.

(Other sizes available up to 250,000 B.T.U.'s/hour).



*For fully illustrated literature and Price List write to—*

## **Monzell, Mitchell & Co. Ltd**

67-73 TOWNSEND STREET — DUBLIN, 2. 'Phone 76282.



## *The* **Nobel** 31

### **Adds Warmth and Luxury**

The 'Nobel' 31 is ideally suitable for lounge bars or in fact all large rooms. The cost of installation is remarkably low and it is most economical on fuel and general maintenance. There are absolutely no fumes with the Nobel 31. Obtainable with either manual or thermostatic controls—It is essential in any hotel.

Write or 'phone for full particulars to:

**DAN KELLY  
& CO.**

31 Upper Baggot St., Dublin 4.  
'Phone 680067.



The Irish Plumber and Heating Contractor.

# B.S.S. LTD.

STOCKISTS FOR:—

## COPPERAD Heating Equipment

- • • for Houses
- Factories
- Stores
- Offices
- Boardrooms

- COPPERAD Wallstrip
- COPPERAD Convectors
- COPPERAD Unit Heaters
- COPPERAD Raystrip
- COPPERAD Fan Convectors

... also all ancillary equipment, including Radiator Valves, Gate Valves, Thermometers, Pressure Gauges, Circulating Pumps, Oil Filters and all Pipeline equipment.

LARGE STOCKS AVAILABLE FROM:

### THE BRITISH STEAM SPECIALTIES LTD. 31 LEESON PARK, DUBLIN.

Telephone: 66961-2-3-4.

## Multipac

the most successful  
WET BACK PACKAGE BOILER

**OIL or SOLID FUEL!**

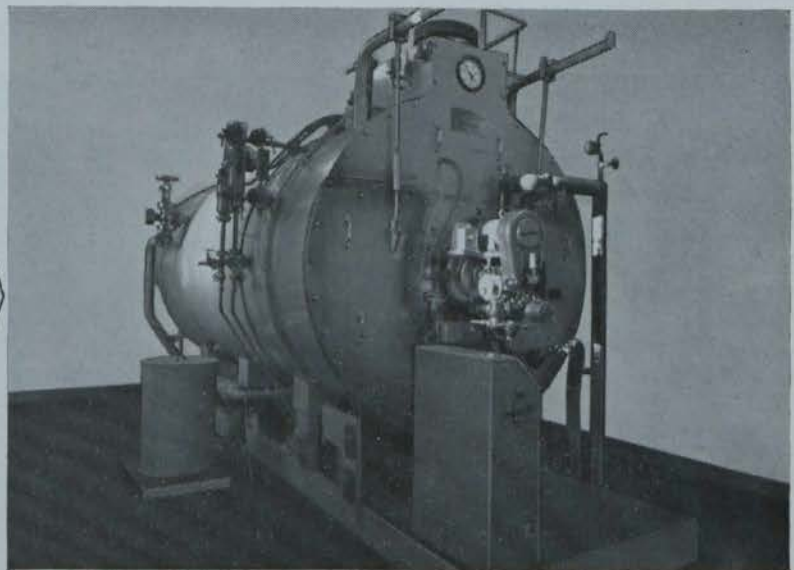

More and more successful installations are proving the outstanding efficiency and economy of the MULTIPAC fully wet back Boiler. And each of these installations is backed by 24-hour round-the-clock after sales service by skilled engineers.

### JOHN THOMPSON (WILSON BOILERS) LTD.

Belfast Office: 16-20 Rosemary Street, Belfast.

Tel.: Belfast 25430.

Head Office & Works: Lilybank Works, Londo Road, Glasgow, E.1.

Tel.: Bridgeton 6311.



TRADE

TOPICS

FROM JOHN A. McMASTER  
OUR NORTHERN CORRESPONDENT

HOLIDAY TIME IN  
THE NORTH

**I**N COMMON with the rest of the building industry in the North of Ireland, the plumbing trade began their annual holiday on July 7 and this will extend to July 23. Heating engineers who, since September last, have been working under their own agreement and are not necessarily subject to building trade rulings, have also taken their annual holidays from the same dates.

That is the general picture, although, of course, the dictates of business commitments will mean some departures from these dates, provided for under the agreements for both trades.

Although the business outlook for the immediate future is not all that rosy in the North, both the plumbing and heating trades can look forward to a busy time when work is resumed.

In recent weeks there has been a tremendous flood of enquiries and news of fairly substantial contracts, some of which are at the stage where invitations to tender have been issued, others in the design stage and still others being prepared for invitation by the consultants.

**Briskly**

The North's extensive factory programme continues as briskly as ever before. A number of Standard Advance Factories are planned, locations have been decided upon for some of these and some Government factories, already occupied and in production, are meeting with such success by their occupants that substantial extensions are being planned.

One major project on which work will be starting soon is the B.P. Refinery at Sydenham, Belfast. All of the main contracts have now been awarded, although B.P. have not yet announced the successful tenderer for the mechanical services and other installations. Site work has already

begun on preparing access roads and work on the foundations for the administration, laboratory and maintenance buildings has commenced.

This development may well call for a number of large factories in the area, creating substantial work for the heating and plumbing trades in the years ahead.

**Development**

Another interesting development is the expanding hospital programme. In almost every county new extensions, or modernisations of existing buildings, are either in hand or at the tender stage.

The extremely severe winter and, as I write in July, the equally chilly summer, has convinced many householders that it would be foolish to face another winter without adequate comfort in the home. Consequently, a tremendous number of enquiries are being received for domestic central heating installations.

Very soon now, autumn publicity programmes will be launched by the oil, gas, electricity and coal interests aimed at bringing home to the householder the advantages of modern

heating—and the ease with which the costs can be met. This, undoubtedly, will result in a very busy winter for the plumbing and heating trades.

**Recession**

The plumbing trade was very badly affected by the recession in the Belfast shipyards, but the Government is now being pressed to make an all-out effort to secure new orders. Emphasis is being placed upon the desirability of these new orders being for passenger liners—with resultant employment for the finishing trades. It is to be hoped that pressure on the Government

will result in some substantial orders—and the re-employment of many of the redundant plumbers. At the same time, it is now being generally accepted that never again will the Belfast shipyards be in a position to offer employment to 20,000 people (the present figure is about 5,500), so that the plumber normally employed in the shipyards must take his place in the queue for employment with the up-town plumbers.

That dull spot apart, the Ulster plumbers and heating engineers can enjoy their summer holiday content in the knowledge that, in the foreseeable future, there will be work in plenty.



● Pictured here is the Lido "Express" from Heatrae Limited of Norwich.

Heatrae's agents in Ireland, Allbro Agencies, 41-53 Nelson St., Belfast 15, advise that the "Express" provides a continuous supply of hot water up to a maximum of 9 gallons per hour.

An "economy eye" gives visual indication of when the current is on and switches off when the water reaches the correct temperature.

*The Irish Plumber and Heating Contractor.*

## ARKLOW FIRM PRODUCE BOILERS, SPACE HEATERS

WELDRYTE LTD., of South Quay, Arklow, are now in production of domestic central heating boilers (vapourising and pressure jet) and space heaters (range: 60,000 to 500,000 B.t.u.'s/hr.).

The following is a brief description of these items:—

**Weldryte Series P.B. 80/140 Oil Fired Boiler:** This boiler has been designed to fill the need for a highly efficient central heating boiler, for the larger home or small building. It is manufactured to the highest standards from 3/16" steel plate.

Unlike most central heating boilers which are overrated, the heating surface to output ratio is very high (4,500 B.Th.U./hr./sq. ft. when running at 100,000 B.Th.U./hr.). This leads to a very high overall efficiency.

**Weldryte Series D 500 Air Heater:** This air heater is designed to fulfil the need for a simple, robust, economical means of space heating. It is suit-

able for heating public halls, factories, churches and workshops. It may also be used for providing hot air for grain drying or hay drying.

Several sizes are available, and special models may be built when the particular application demands. Various types of fans are available for the different applications, and advice in this respect is fully available.

This series gives the equivalent of 150 1 K.w. electric fires. Rating: 300,000—500,000 B.t.u.'s/hr.

● Accompanied by his wife, son and daughter, French industrialist M. Henri Potez early this month visited his heating unit factory at Galway. M. Potez was on a routine visit to the Potez aircraft factory being built at Baldonnel (Co. Dublin).

**For the record:** Brightside Heating and Engineering Co. Ltd. has no connection with Brightside Engineering Company (Ireland) Ltd. Readers may have thought that the two companies were connected when reading the listings in last month's special Directory issue.

# TRADE

# TOPICS

## LAST YEAR "MOST DIFFICULT" FOR UNIDARE

IN HIS annual review the Chairman of Unidare Ltd. pointed out that last year was one of the most difficult periods in the history of the company. Great effort had resulted in an increase of 13½ per cent. in turnover compared with the previous year. Home sales were slightly increased and exports were up 24 per cent. However, this was not sufficient to absorb general salary increases.

During the period under review the heating sections continued to show expansion. In the water, aluminium and steel sections there was a slight improvement in trading.

Net profits fell from £161,851 to £125,454 and, as already announced, the ord. div. was reduced from 12½ to 8 per cent.

# Not any more

They never did use small boys for cleaning boiler tubes—  
and the idea is as dated as hand brushing  
now that Airnesco brush automation is available  
for water tube boilers, waste heat boilers,  
and economic type boilers.

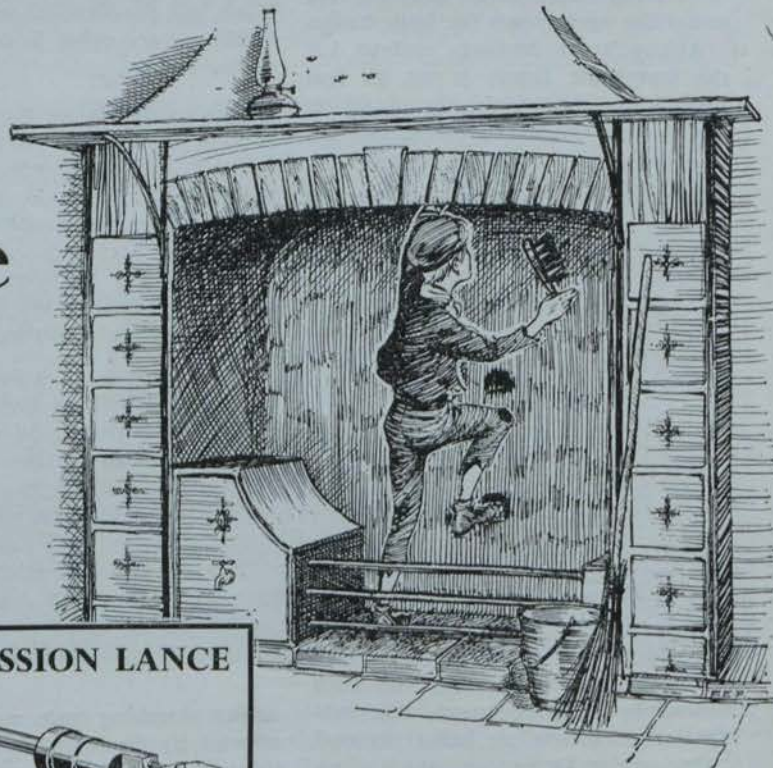

**AIRNESCO PRODUCTS LTD.**

For further details of these and other Airnesco Products, and for a free demonstration in your own works, write now to

**FERRET**

'Walks' along the tube—no pushing or pulling—the operator stands still and waits for the 'Ferret' to push itself up the tube and return to him.

**PERCUSSION LANCE**

Cleans a 300 tube fire tube boiler in 30 mins—without brushing—by air puffs alone.

**SPECIAL  
SURVEY**

# PRODUCT REVIEW

(Continued)

ITEMS from the range of unit air conditioning equipment made by Tempair Ltd., include the Pacific series of wall or window mounted unit air conditioning equipment with capacities ranging from 11,600 to 16,000 B.t.u. per hour. A specially designed version of the Pacific has been rendered safe for use in operating theatres where risk of explosion from anaesthetic gases sometimes exists.

The larger Director console air conditioning unit is rated at 16,000 to 17,000 B.t.u. per hour. Also available is a cellar cooler designed to maintain temperatures between 50 to 60 degrees F. with remote condenser, either air cooled or water cooled, and having a capacity of 16,000 B.t.u. per hour.

★ ★ ★

WITH THE addition of two recently introduced heat pump air conditioners, the Land and Products Division of Thermotank Ltd., Rochester Row, London, can now offer a complete range of Westington Heat Pumps,

with cooling capacities of 15,350 and 17,750 B.t.u./hr., and heating capacities of 15,000 and 46,000 B.t.u./hr.

These units are true heat pumps. By incorporating a reversible cycle in the design of the units, heating or cooling can be effected quickly and easily to suit changeable climatic conditions.

The overall dimensions on the units in the HB series—in both 15,350 and 17,750 B.t.u.'s per hour cooling capacities—are the same, 72½" high and 12½" deep. The smaller capacity model is 25½" wide and the larger model is 31" wide. All units are housed in attractive aluminium casings, which are exceptionally hard wearing.

Irish agents: J. & E. Hall Ltd., Anglesea St., Dublin, and Thermotank Ltd., P.O. Box No. 5, Queens Road, Belfast, 3.

continued overleaf

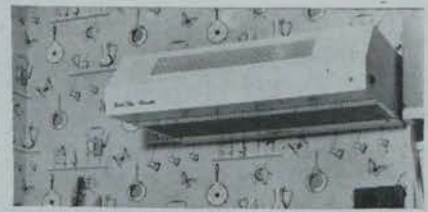

DESIGNED primarily for kitchens, this new unit is now being marketed for the first time in Ireland as the "Gold Star" Ductless Hood, the sales emphasis being on the avoidance of any necessity for ducts, pipes, or structural alterations. Instead the unit is simply hung on the wall on two screws supplied with walls plugs so that mounting on any wall surface is at most a 15 minute job (pictured here).

The air-cleaning principle is by two-stage filters—the first of double sided expanded metal with fabric filter to arrest the passage of dust, smoke and grease to the second stage filter.

The fan has a capacity of 60 cu. ft. of air per minute. For domestic use the Hood is available in two widths, 24" and 36". W. L. Crowe, Ltd., East Wall, Dublin, are the sole importers.

# LAPINUS ROCKWOOL THERMAL INSULATION

Used Extensively in Industry, Heating and Refrigeration Trades and for Sound Proofing

- SUPPLIED IN LOOSE FORM, BLANKETS, SLABS AND RIGID PIPE SECTIONS

**Irish Agents: THE TECHNICAL EQUIPMENT CO. LTD.**

2 FITZWILLIAM PLACE, DUBLIN, 2.

Stores and Workshops:  
9a Harcourt Road, Dublin.

Telephone: 61901-62032.

from previous page

**TECHNICAL EQUIPMENT CO. LTD.**, Fitzwilliam Place, Dublin, are representing in Ireland the products of N. V. Nederlandse Steenwolfabriek, Bijlstraat, Rotterdam, Holland, who manufacture Lapinus Rockwool insulating material used against heat, cold, and sound.

From their range we note the loose Rockwool long fibres, resistant to temperatures up to 1,300 degrees F. All Lapinus Rockwool products, bonded and unbonded, are incombustible, inorganic, rotproof, with no substratum for fungi or other organisms. They have an extremely low thermal conduction co-efficient.

★ ★ ★

**FIBREGLASS** Superfine insulation has been used in the specialised field of aircraft and marine insulation where its excellent handling properties, maximum efficiency at minimum weight, resilience and strength have been of considerable value.

Superfine insulation is produced by a unique process which at very high temperature converts high quality

glass to long fine, shot-free fibres with diameters ranging from .00007" to .00014", many times finer than in other types of insulation.

Superfine is widely used for the insulation of air conditioning duct systems. These can represent a considerable hazard in facilitating the rapid spread of a fire through a structure, unless the choice of materials is rigorously controlled.

Superfine obtains the highest classification of fire safety when tested in accordance with B.S. 476 : 1953—Class 1, spread of flame. In fact there is no spread of flame whatsoever during the test.—Fibreglass Ltd., 21 Merrion Square, North, Dublin.

★ ★ ★

**ROCKSIL-K** is the name Cape Insulation and Asbestos Products have given to the new fine fibre Rocksil rock wool now being produced at Rocksil works, Stirling. Volume for volume, Rocksil-K is half the weight of standard Rocksil.

The first product to be made in the new fine fibre was resin bonded insulation. They were made in four densities—1 lb., 1½ lb., 1¾ lb., and 2 lb.—and have taken the place of the standard Rocksil Extra Light Density Slab, Light Density Slab, Felted Mat,

and Lightly Bonded Mat. Slabs and rolls are made plain without any finish and also faced with p.v.c. Available from M. A. Boylan Ltd., 50a Harcourt St., Dublin.

★ ★ ★

RECENTLY introduced is Newalls Super Glass Fibre bonded Mat. It features glass fibres bonded with thermo-setting resin into a tough but light and pliable mat. It is manufactured in three grades to provide various degrees of insulation.

Also available are Super glass fibre "Interclad"; super glass fibre mattresses; super glass fibre resin bonded slabs; and super glass fibre Loose Wool. All from Newalls Insulation Company Ltd., 200 Agnes St., Belfast.

★ ★ ★

THE P.H. cylinder jackets are available in hygienic washable plastic covers of light blue, red, white, peach, and dark green. Jackets to cover hot water tanks and cold water cisterns are available in sizes ranging from 17" x 17" x 24" high to 24" x 15" x 24" high. Other sizes are available on request. From P.H. Thermal Products Ltd., Baildon, Yorkshire. Irish agent is G. F. Morley Ltd., Quinn's Lane, Fitzwilliam Square, Dublin.

## Thermal Insulation



### M. A. Boylan Limited

A subsidiary of The Cape Asbestos Company Ltd.,  
50a Harcourt Street, Dublin.  
Telephone: 52397, 54485 and 51787



We are the foremost insulation specialists in the country with many important insulation contracts to our credit. The huge Oil Refinery at Whitegate and the Derrinlough Briquette factory are recent examples. If you have any heat-loss problem, discuss it with our highly experienced technical staff. Our recommendations are offered free and without obligation.

Sole agents and stockists for:

'Rocksil' rock wool

Rigid Sections

Flexible Sections

Blankets

Mattresses (wire-mesh-backed)

Loose Wool

'Caposite' amosite asbestos

moulded blocks and pipe sections

Also full range of plastic materials and hard-setting compositions.



## SANITARY WARE IN WHITE AND COLOUR

(Colours to match Irish Foundries Ltd.)

Agent:

**C. B. SHERIDAN**  
10 HERBERT PLACE  
DUBLIN.

Phone 66283.

Illustrating  
"THE WALDORF SUITE"

## JOHNSON AND SLATER

(VITREOUS CHINA)

ALFRED JOHNSON & SON LTD.,  
QUEENBOROUGH, KENT.

(SANITARY FIRECLAY)

JOHN SLATER (STOKE) LTD.,  
BERRY HILL, STOKE-ON-TRENT.

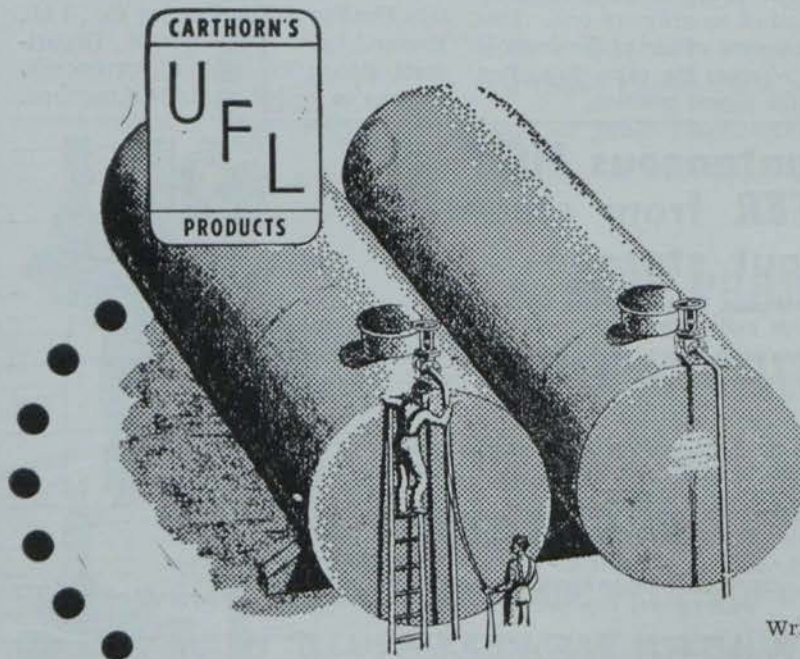

# WELDED STEEL TANKS

FOR FUEL OIL STORAGE AT  
DOMESTIC AND INDUSTRIAL  
INSTALLATIONS.

ALL CAPACITIES  
B.S.S. & A.P.I. SPECIFICATIONS

Write for our illustrated "Standard Tanks" Folder.

Sales Company for  
**UNIVERSAL  
FABRICATORS**  
(Dublin) Ltd.

# CARTHORN

(1949)  
LTD.

Commercial Buildings  
Dome Street, Dublin  
Tel. 73475

Northern Ireland: W. D. Craig & Co., 32 Arthur Street, Belfast.

## QUESTIONS ANSWERED

from page twenty-eight

### Best roof for a septic tank

Would you please let me know the best kind of roof for a septic tank. That is, would you carry the inlet and outlet junctions through the roof and fit a grid on these, or would you just fit two metal covers over inlet and outlet junctions? Also, would you fit a mica flap fresh air inlet at the intercepting trap chamber to leave free passage of air out of soil vent pipe?

**T**HE putrefactive conditions encouraged in a septic tank as a prelude to purification, is promoted by naturally occurring organisms called Anearobics. These can survive quite happily without air, but they can also thrive where air is present. Because of this facility they are referred to a facultative bacteria. They do, however, seem to prefer warm dark airless environments. It is for this reason, and for the safety of "proglers," that septic tanks are generally roofed over.

This being understood, the choice of suitable roofing is a wide one. Stout but jointed timber might be used. Butted concrete planks would do very well. Both these methods have several advantages. They are relatively cheap—much cheaper than a cast concrete roof. They offer adequate ventilation of the tank through the butted joints. The planks, either of wood or concrete, are easily put in place, and just as easily removed to give access to rod the dip pipes, or to inspect or clean the tank. And they are effective in all respects—why look further?

The writer has designed, supervised construction, and been responsible for subsequent good operation of septic tank installations, large and small. In all cases no more complicated

roofing was adopted. All installations proved very satisfactory.

From the foregoing it will be gathered that no individual vents to dipping inlet and outlet pipes will be required if plank roofing is used. If an intercepting trap is fitted in the manhole just before the septic tank, then a mica flap F.A.L. IS necessary to ensure inflow of air in the all important ventilation of the upstream drainage system and its connected branches and soil-vent pipework.

### Cost Money

**B**UT why have an intercepting trap?

These cost money. They are also known to be the most prolific cause of drain blockage there is. What are they for? They are intended to act as a water barrier to stop, in this case, septic tank smells from entering the house drainage system. If cleaning eye stoppers be fitted to the up-looking socket of the inlet dipping tee piece within the septic tank, the fact that its outlet is submerged below water level makes this arrangement a most effective trap in itself. And this, at no extra cost and without risk of blockage.

Having done this, one can now discard the costly F.A.I. by substituting an iron grid cover to the final manhole instead of an ordinary one. This gives free access of air to the drain at all times whereas the mica flap often sticks in the closed position.

If it doesn't stick closed, it sticks open—have a look around; you will see many in this state. Does anyone complain of smells coming out? No! and no one will complain of smells from the suggested open grind air inlet either. The writer has adopted this method for many years with success.

### RUSSIAN INTEREST IN BRIGHTSIDE TECHNICAL ABSTRACTS

**B**RIGHTSIDE HEATING AND ENGINEERING CO. LIMITED, of Sheffield, have arranged, through their Research and Development Department in Portsmouth, for an exchange of information on current Heating and Ventilating literature with the State Scientific and Technical Library of the USSR in Moscow.

Brightside's Research and Development Department publish quarterly a review of technical articles in the field of heating and air conditioning, abstracted from current writings in journals from all over the World, and the USSR State Scientific and Technical Library has asked to be included on the mailing list, in exchange for which they send to Brightside their own relative publication Teploenergetika.

Copies of the current abstracts are available freely on request to Brightside Heating & Engineering Co., Ltd., Research and Development Department, Anson Rd., Milton, Portsmouth, and can be mailed regularly if required.

### Instantaneous HOT WATER from steam—without storage

Cox Steam and Water Mixers deliver from 50 to 24,000 gallons per hour.

They operate with the highest efficiency at all pressures. Silent, efficient, compact and easy to install, replacing bulky and costly calorifiers.

#### MODELS:

- ★ (1) BABY COX (½") for wash-basins, sinks, etc.
- ★ (2) JUNIOR COX 1-5 (¾"-2") for process work, vats and general purposes.
- ★ (3) SENIOR COX (2½"-8") for large volumes of hot water for process hot water supplies.

**NO TIME LAG - NO STORAGE - NO STEAM TRAPS  
NO LOSS OF CONDENSATION - NO MOVING  
PARTS TO GO WRONG**

### COX WATER HEATERS

Manufactured by COX ENGINEERING CO. LTD.  
Dept. IP.6., 14 Park Lane, Sheffield, 10.  
Tel.: 62483. Telegrams: "Heaters Sheffield"

#### Agents:

Halpin & Hayward Ltd., Unity Buildings, 16-17 Lower O'Connell St., DUBLIN. Tel. 43270.  
Bedford Buildings, 7 Bedford St., BELFAST. Tel. 26343.

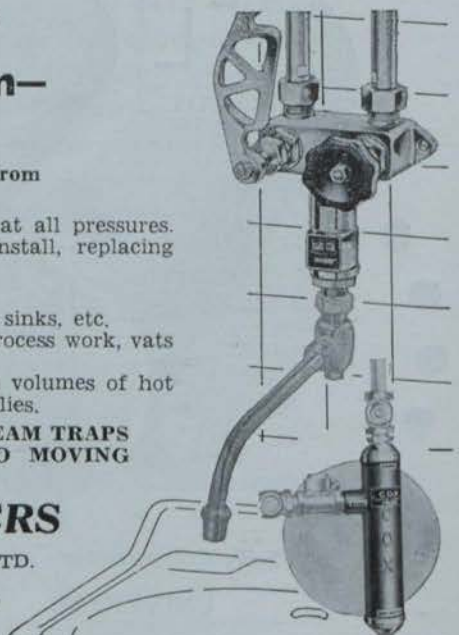

**FOR BETTER  
QUICKER  
LOWER COST  
PLUMBING!** .....

**SANBRA-CONEX**  
**(Ireland) Limited**

**OFFER A COMPLETE RANGE OF  
PLUMBERS BRASSFOUNDRY TAPS & FITTINGS**



5302 Bibcock



290 Trap



5301 EC. Pillarcock



086 Lavatory Waste

The CONEX Compression Joint is everywhere recognised as the simplest, speediest, strongest and most economical joint for copper and plastic tubes. It is approved by leading Water Authorities throughout Ireland. In addition to a wide range of CONEX Compression Joints and Fittings, Valves, Stopcocks, and Drawn Copper Traps, we can supply an extensive range of Brass Traps, Pillarcocks, Bibcocks, Wastes, Plugcocks, etc. Your enquiries will receive our immediate attention.

★ **VERY PROMPT DELIVERIES**

★ **ATTRACTIVE PRICES**

**HOT BRASS PRESSINGS TO SPECIFICATION  
POLISHING & CHROME PLATING CAPACITY**

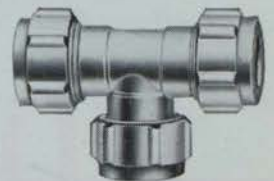

12x Tee-Piece



171x Combined Fitting



53x Stopcock



1650 Valve

**FREE! WRITE TODAY FOR YOUR FREE COPY  
OF OUR FULLY ILLUSTRATED CATALOGUE**

**SANBRA-CONEX (IRELAND) LIMITED**

**SANTRY AVENUE, SANTRY, CO. DUBLIN.**

Telephone: Dublin 373637. Telegrams: SANCO, DUBLIN.



**BUDERUS - QUADRANT - BUDERUS - QUADRANT - BUDERUS**

**Oil  
Turf  
Anthracite  
Coke  
Gas**

**BUDERUS BOILERS**

**From 46,000 B.T.U.'s  
to 3,000,000 B.T.U.'s**

**(Panel and Column Radiators available on  
short delivery)**

● Buderus boilers are gaining on others for high efficiency, pleasing appearance, competitive prices and especially quick delivery. (Many sizes now from Dublin stock).

**Write for our  
stock price  
list**

Sole Agents:

**QUADRANT ENGINEERS**

6 Mount St. Crescent, Dublin, 2.

Telephone 61492.



**CAST IRON**

**BOILERS**

